

THIS DRAWING IS UNPUBLISHED. RELEASED FOR PUBLICATION
 © COPYRIGHT - By - ALL RIGHTS RESERVED.

LOC		DIST		REVISIONS			
P	LTR	DESCRIPTION		DATE	DWN	APVD	
-	-	A	RELEASED PER ECO 11-021255	10-24-11	CT	MS	

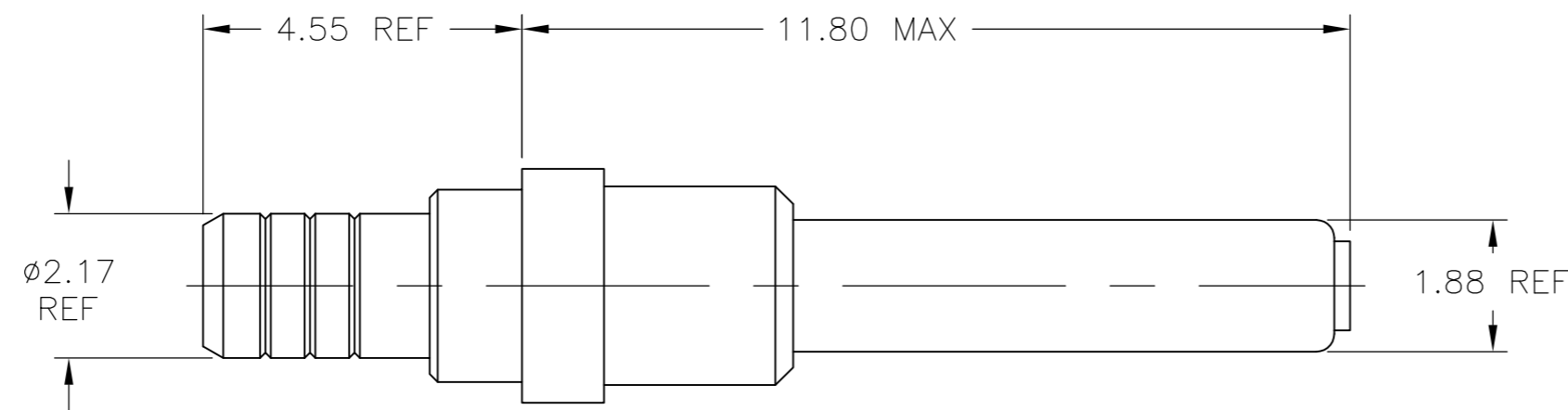

OUTER CONTACT

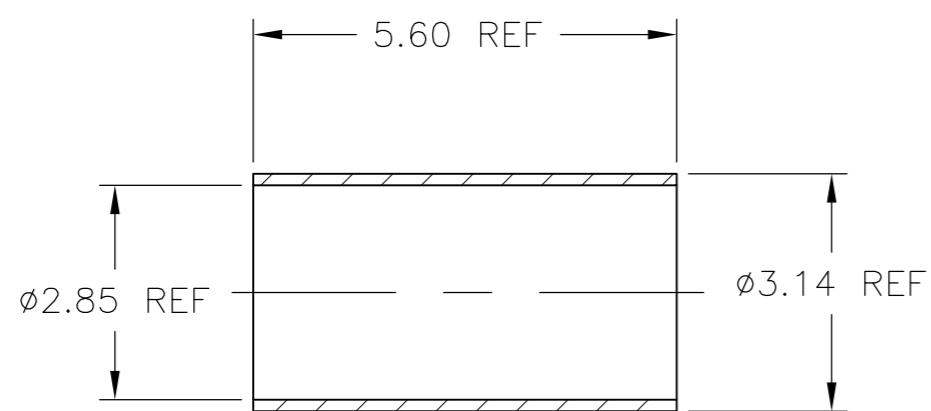

FERRULE

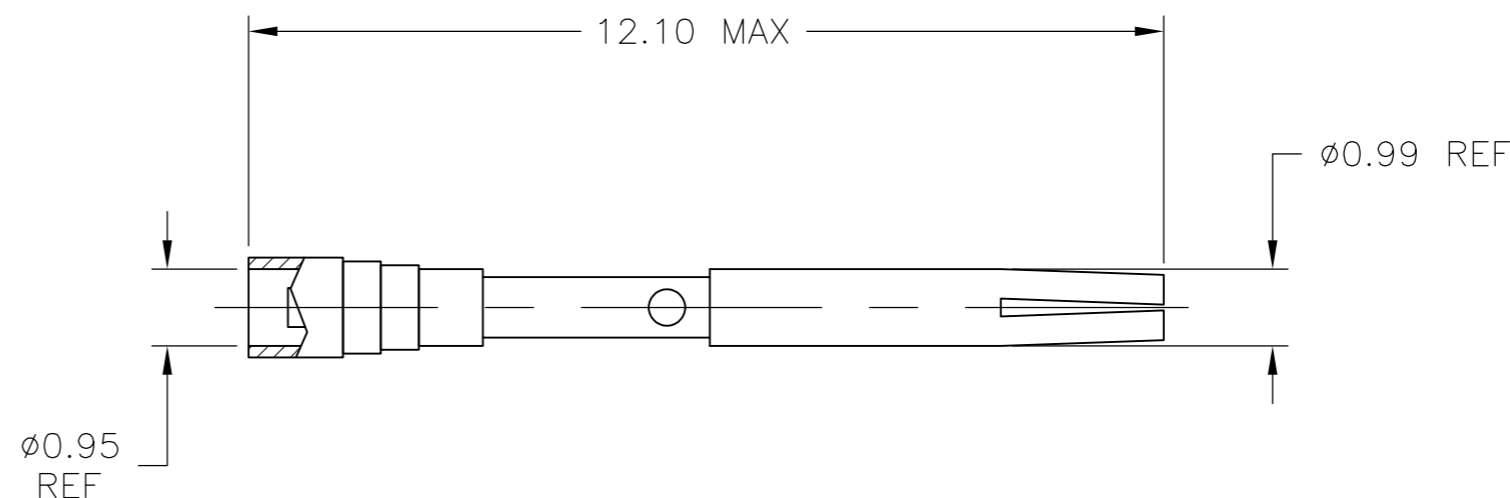

CENTER CONTACT

- MATERIAL:**
 OUTER CONTACT, CENTER CONTACT AND FERRULE: COPPER ALLOY
 PROTECTING TUBE: PASSIVATED STAINLESS STEEL
 DIELECTRIC: PTFE
- FINISH:**
 OUTER CONTACT, CENTER CONTACT AND FERRULE: GOLD PLATE OVER NICKEL UNDERPLATE
- CRIMPING TOOLS:** (CRIMPED CONTACTS WILL SHOW NO CRACK WHEN INSPECTED PER MIL-C-22520 AT 10x)
 CENTER CONTACT:
 BASIC TOOL: M22520/2-01 (REF TE P/N 601966-1)
 OUTER BODY CONTACT:
 BASIC TOOL: M22520/4-01 (REF TE P/N 601963-1)
 DIE: (REF TE P/N 1738337-1)
- EXTRACTION TOOL:** M8 1969/1-03 (REF TE P/N 91066-3)
- APPLICABLE CABLES:** RG174, RG179, RG-316- KX22.
- THIS PRODUCT SOLD BY TE CONNECTIVITY UNDER A LICENSE FROM RADIAL SA.**

1738025-1
 PART NO.

THIS DRAWING IS A CONTROLLED DOCUMENT.		DWN	C.C.THOMAS	24OCT2011	TE TE Connectivity	
DIMENSIONS: mm		CHK	M.SPICER	10-24-11		
TOLERANCES UNLESS OTHERWISE SPECIFIED:		APVD	M.SPICER	10-24-11	NAME	
0 PLC ± -	1 PLC ± -	PRODUCT SPEC	PIN CONTACT KIT, SIZE 15, COAX, GPR			
2 PLC ± -	3 PLC ± -	APPLICATION SPEC	SIZE	CAGE CODE	DRAWING NO	RESTRICTED TO
4 PLC ± -	ANGLES ± -		A2	00779	C=1738025	-
MATERIAL	FINISH	WEIGHT	CUSTOMER DRAWING		SCALE	SHEET
-	-	-	10:1		1	1
					REV	A