

THIS DRAWING IS UNPUBLISHED
 RELEASED FOR PUBLICATION 2006
 © COPYRIGHT 2006 BY TYCO ELECTRONICS CORPORATION. ALL RIGHTS RESERVED.

LOC	DIST	REVISIONS			
P	LTR	DESCRIPTION	DATE	DWN	APVD
A	-	NEW PART, NEW DRAWING	24MAY2006	MK	KR
B	-	E-06-028097	04JAN2007	MK	KR
C	-	E-07-028159	22NOV2007	MK	KR

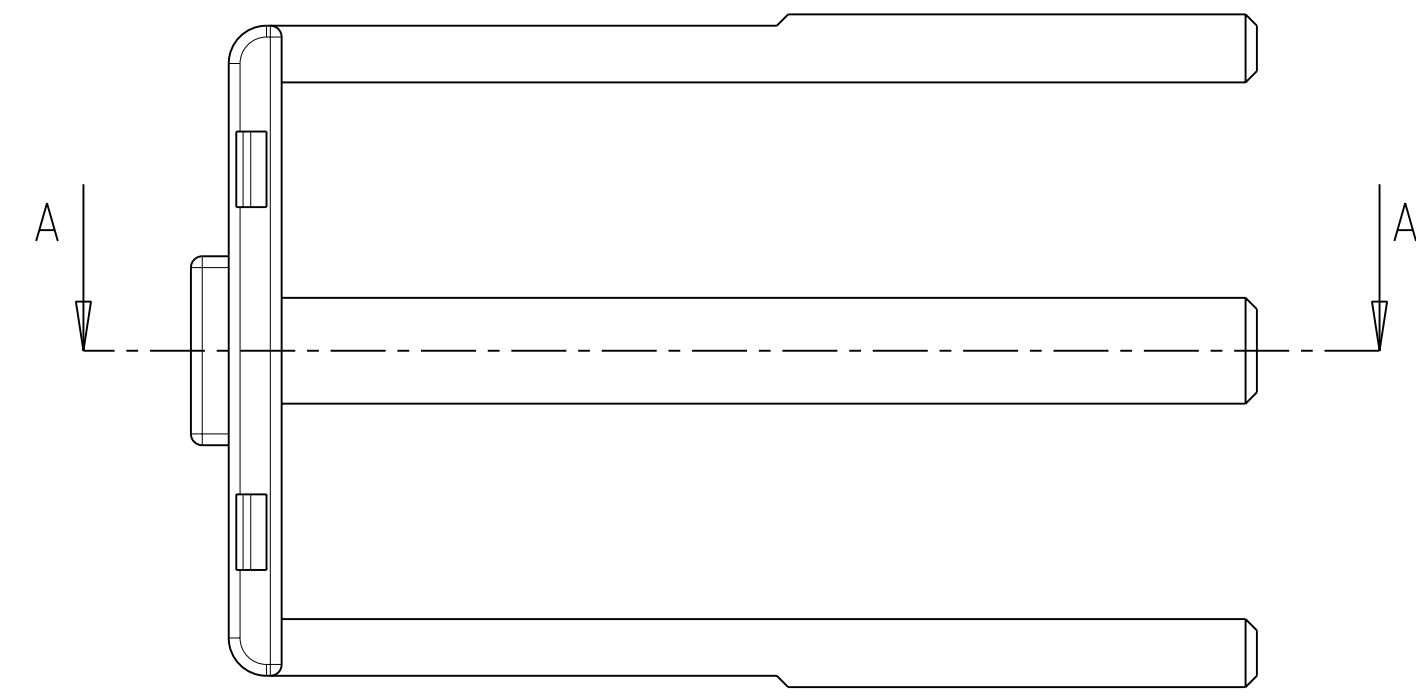

A-A

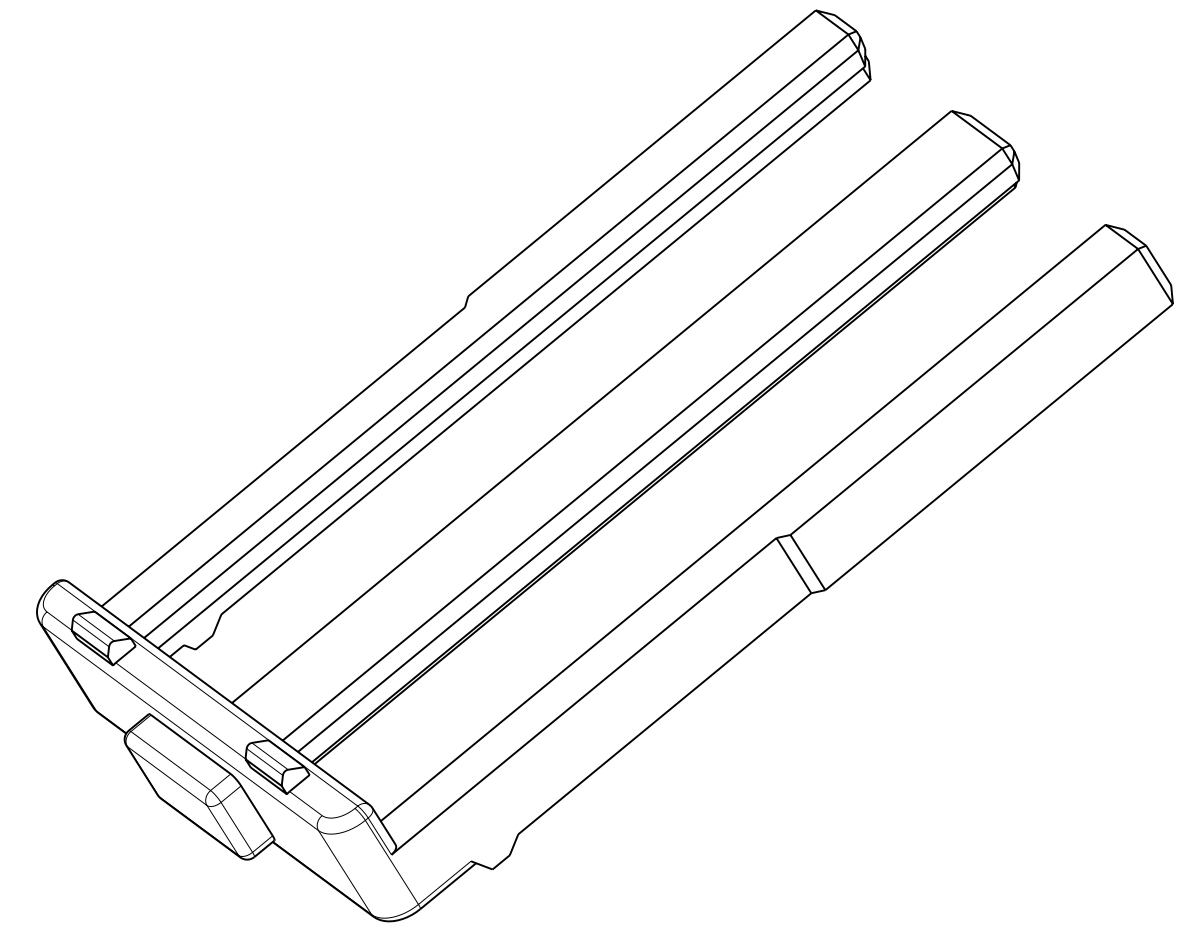
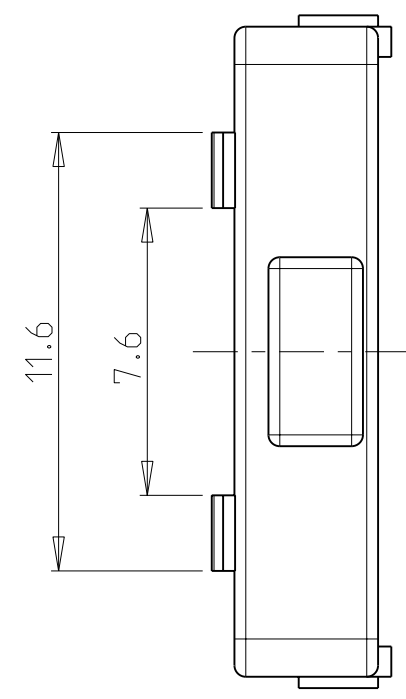
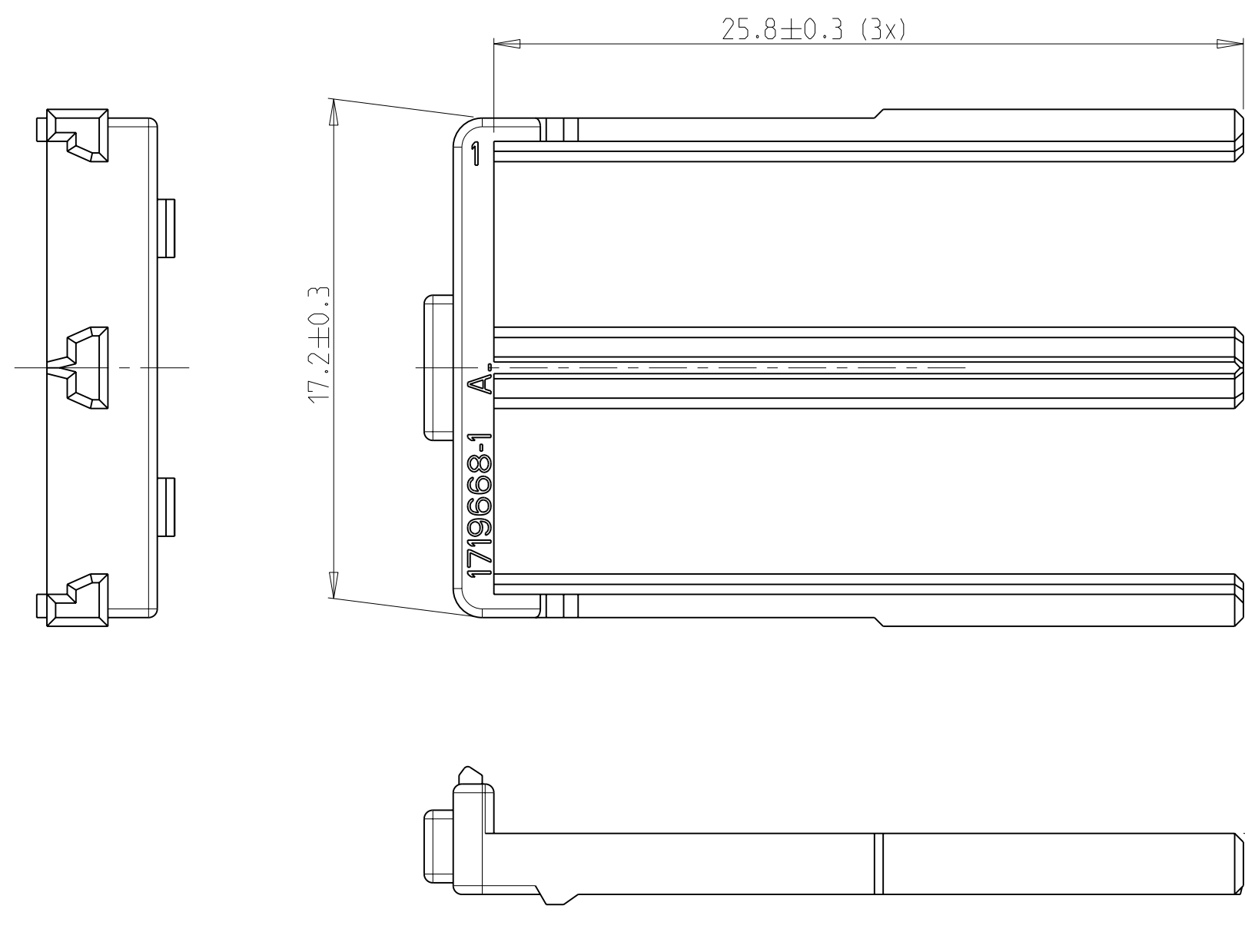
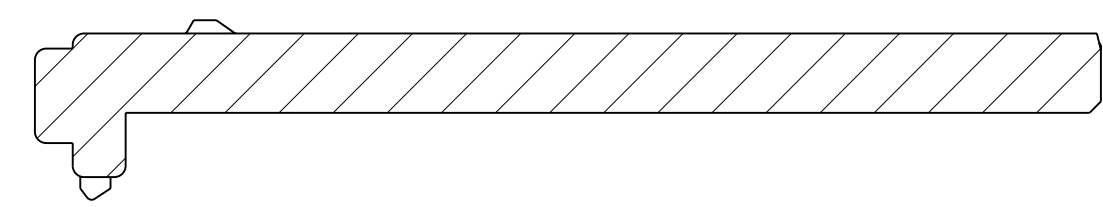

- NOTES:
Bemerkungen:
- PACKAGING: LOOSE PIECE IN CARDBOARD BOX
Verpackung: Teile lose beige stellt in Karton
 - MATED WITH:
verwendet mit:
- | | |
|-------------------|-----------|
| REC. HSG. 48 POS. | 0-1719678 |
| REC. HSG. 48 POS. | 0-1719683 |
| REC. HSG. 48 POS. | 0-1418416 |
| REC. HSG. 48 POS. | 0-1670067 |
| REC. HSG. 48 POS. | 0-1670068 |
| REC. HSG. 48 POS. | 0-1670069 |

PART NO	REVISION	MATERIAL	DESCRIPTION	COLOUR	ITEM NO
0-1719668-1	C	PA66-GF25	2NDRY. LOCK FOR MOS CB TERMINALS	RED	1

THIS DRAWING IS A CONTROLLED DOCUMENT FOR TYCO ELECTRONICS CORPORATION. IT IS SUBJECT TO CHANGE AND THE CONTROLLING ENGINEERING ORGANIZATION SHOULD BE CONTACTED FOR THE LATEST REVISION.		DWN M. Kressmann 19MAY2006	tyco Electronics AMP GmbH D - 64625 Bensheim	
DIMENSIONS: mm		CHK K.ROTH 24MAY2006	NAME 2NDRY. LOCK FOR 48 POS. 2.NDRY. LOCK	
TOLERANCES UNLESS OTHERWISE SPECIFIED: 0 PLC ±0.3 1 PLC ±0.3 2 PLC ±0.3 3 PLC ± 4 PLC ± ANGLES ±1° FINISH		APVD -	PRODUCT SPEC -	RESTRICTED TO -
MATERIAL -		APPLICATION SPEC -	WEIGHT -	SIZE A2
		CUSTOMER DRAWING	SCALE 5:1	SHEET 1 OF 1 REV C