

THIS DRAWING IS UNPUBLISHED. VERTRÄULICHE UNVERÖFFENTLICHTE ZEICHNUNG. RELEASED FOR PUBLICATION FREI FÜR VERÖFFENTLICHUNG. 2007. MATED WITH: PASSEND ZU: BY TYCO ELECTRONICS CORPORATION. ALL RIGHTS RESERVED. ALLE RECHTE VORBEHALTEN. COPYRIGHT 2007.

LOC	DIST	REVISIONS					
A1	-	P	LTR	DESCRIPTION	DATE	DWN	APVD
PROJEKT NR.: EGATN06136		A1		NEW DRAWING	26CT2007	RD	BL

NOTES

- 1 SUITABLE CONTACT E.G.: 1355719 (WIRE RANGE 0.14-0.22mm<sup>2</sup>)  
928918 (WIRE RANGE 0.20-0.50mm<sup>2</sup>)  
963716 (WIRE RANGE 0.75mm<sup>2</sup>)
- 2 PACKAGING: LOOSE PIECE IN CARD BOX
- 3 WARPAGE 0.4MM PERMITTED

OPENING GUIDE: TO OPEN THE LOCKED RETAINER, USE A Ø 1x0.18MM SCREWDRIVER AND PUSH IT IN THE SHOWN OPENING.  
Öffnungsanleitung: Zum Öffnen des verrasteten Deckels wird ein Ø1x0.18mm Schraubendreher in die gezeigte Öffnung gedrückt.

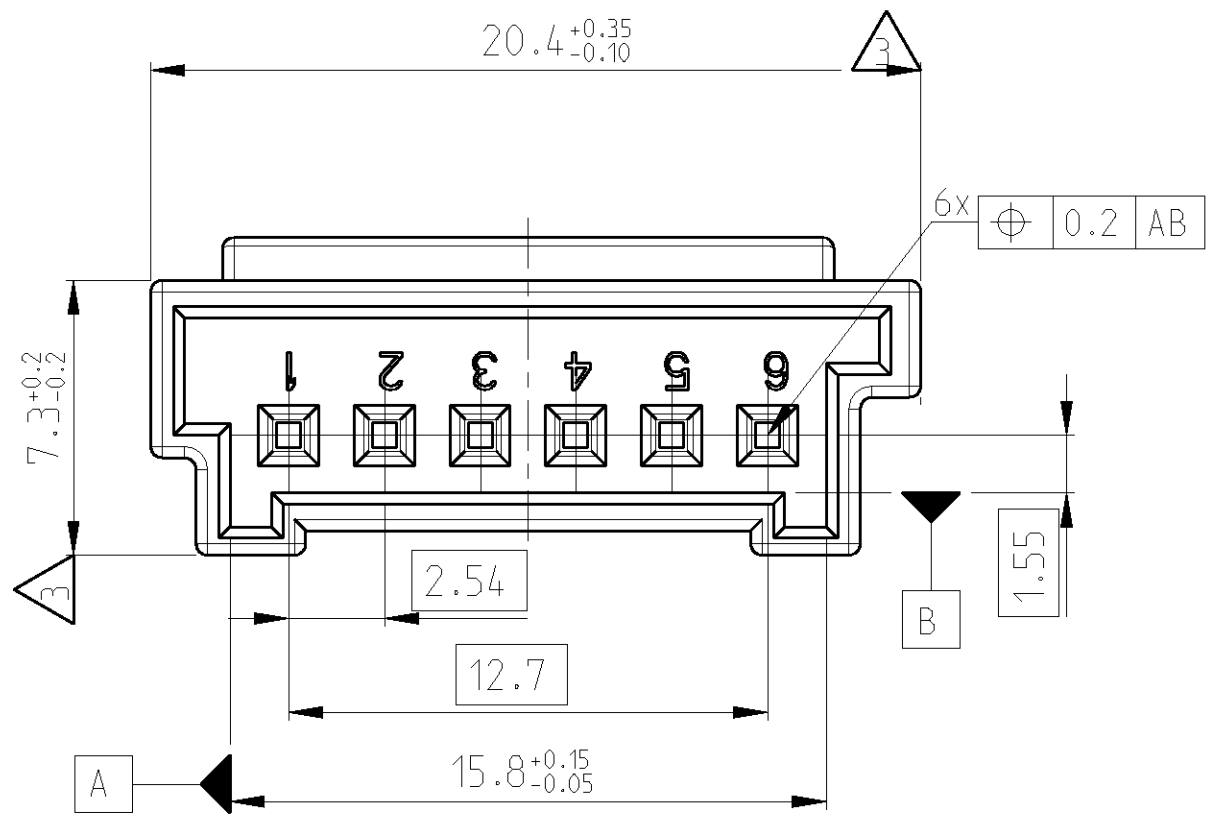

Bemerkungen

- 1 Passender Kontakt, z.B.: 1355719 (DGB 0.14-0.22mm<sup>2</sup>)  
928918 (DGB 0.20-0.5mm<sup>2</sup>)  
963716 (DGB 0.75mm<sup>2</sup>)
- 2 Schuettgut in Karton
- 3 Formbedingter Verzug zul. 0.4mm

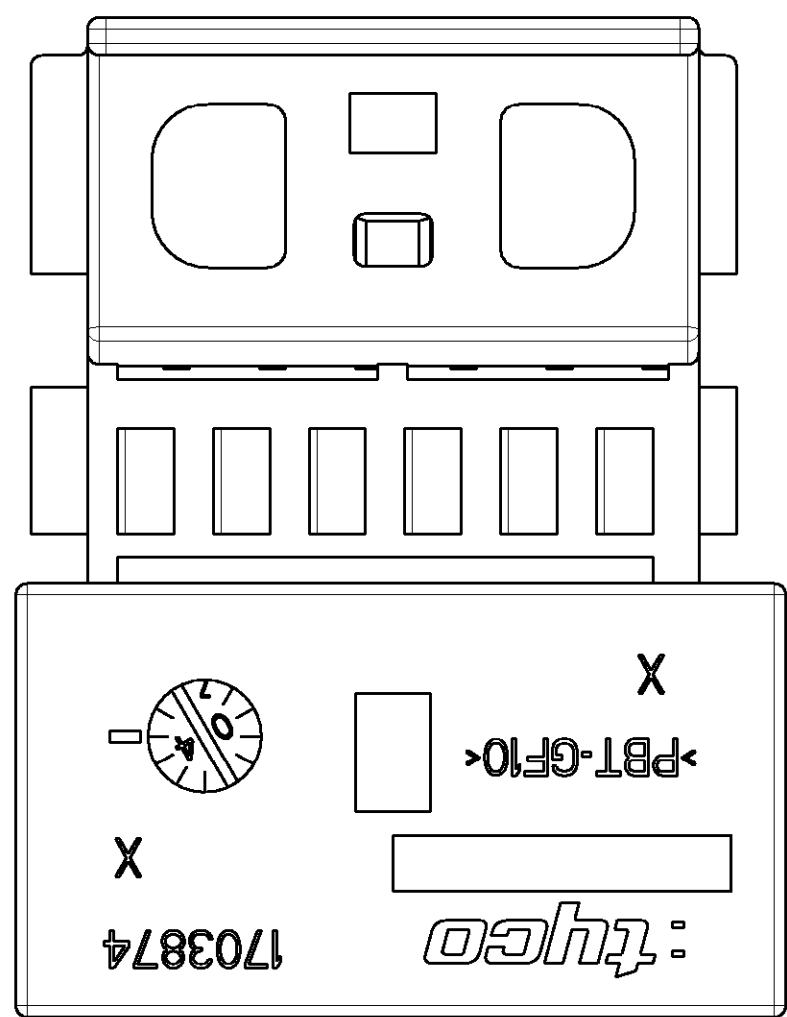

0-...-1 AS SHOWN / wie gezeichnet

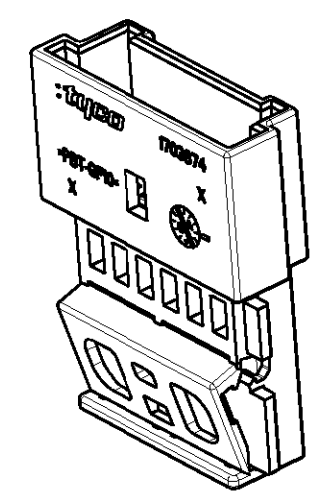
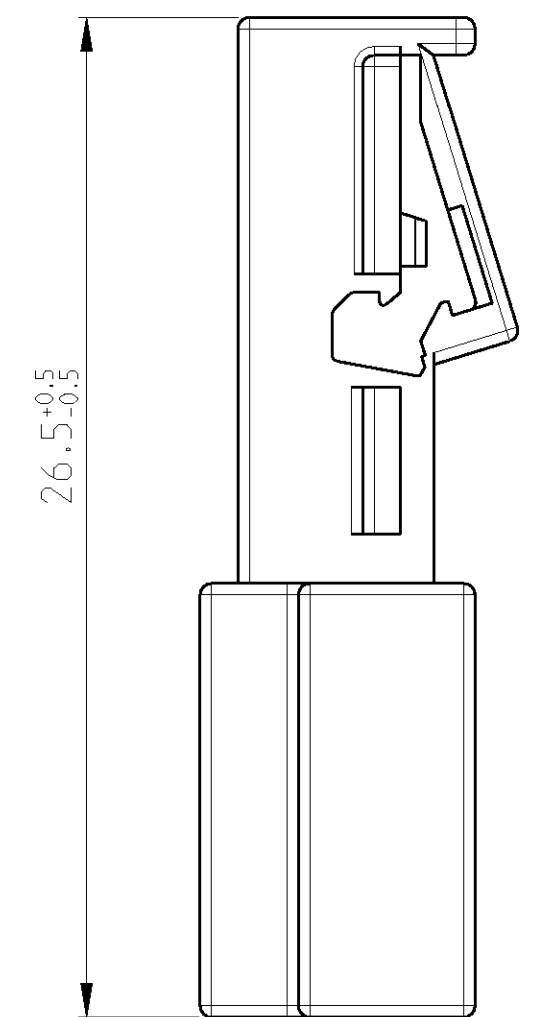

2:1

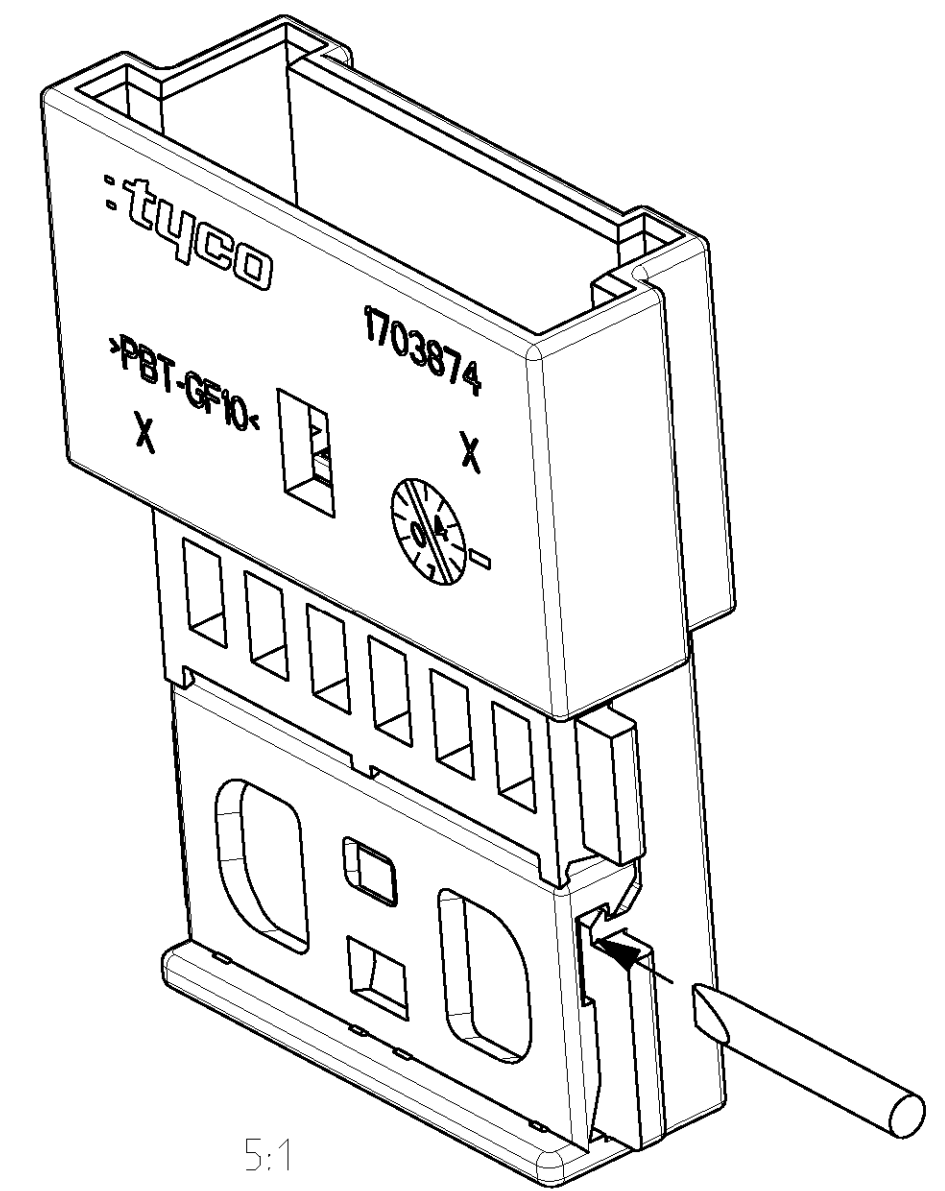

5:1

1703874-1	A	A	BLACK	PB-GF10	9011	20%	1.81
TE PART NO. TE-Teile-Nr	REV	COD. Kod.	COLOR Farbe	MATERIAL	SIM. RAL ähnl. RAL	REGRIND	WEIGHT Gewicht (g)
DWN R.Dierkes 26OCT2007		CHK B.Leonhardt 26OCT2007		Tyco Electronics AMP GmbH 64625 Bensheim (Germany)			
DIMENSIONS: MASSEINHEITEN: (MM)		TOLERANCES UNLESS OTHERWISE SPECIFIED: ALLGEMEINTOLERANZEN		NAME 6POS. TAB HSG.. MQS 6pol. Stiftgehäuse, MQS			
MATERIAL		FINISH/OBERFLÄCHE/FARBE		SIZE A2		CAGE CODE 00779	
-		-		DRAWING NO. ZEICHNUNGS-NR. 1703874		RESTRICTED TO NUR FÜR	
-		-		SCALE MASSSTAB 5:1		SHEET BLATT 1 OF 1	
-		-		CUSTOMER DRAWING KUNDENZEICHNUNG		REV A1	