

THIS DRAWING IS UNPUBLISHED.

RELEASED FOR PUBLICATION

20

© COPYRIGHT 20 BY -

ALL RIGHTS RESERVED.

REVISIONS

P	LTR	DESCRIPTION	DATE	DWN	APVD
	D	New Drawing	22FEB2016	W I	GS
	D1	ECR-19-000210	09JAN2018	W I	GS

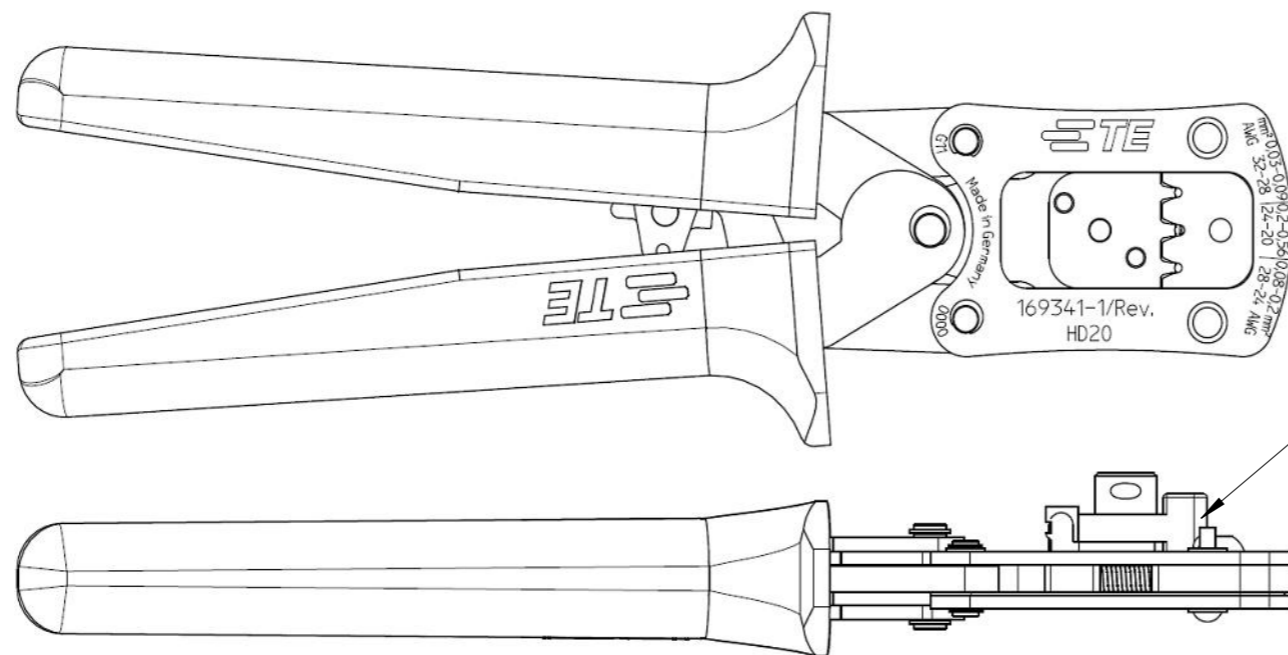

# HAND TOOL HD20 0,03 - 0.56 SQMM



Kontaktpositionierer als Ersatzteil  
erhaeltlich TE PN 4-539785-7  
Contact locator as spare part  
available TE PE 4-539785-7

Kontakt	Nest	Querschnitt	Drahtcrimp/Wire Crimp		Isolationscrimp/Insulation Crimp		Abisolierlänge	Isolat. Ø	Betriebsanleitung
Contact	Crimp Profile	Wire Size mm <sup>2</sup>	Hoehe/Height mm	Breite/Width mm	Hoehe/Height mm	Breite/Width mm	Stripping Length (mm)	Insul. Ø	Instruction Sheet
166997 166998	1	0.03-0.09 AWG 32-28	0.53 ±0.05	0.84	1.20 ±0.1	1.40	2.15-2.65	1.3-1.5	411-19138
66504 66506	2	0.20-0.56 AWG 24-20	0.80 ±0.05	1.40	1.55 ±0.1	1.60	2.15-2.65	1.0 max.	
66505 66507	3	0.08-0.20 AWG 28-24	0.72 ±0.05	1.07	1.20 ±0.1	1.40	2.15-2.65	0.5-1.0	

Dimensions:  
195x63x30 mm (LxW xH)

THIS DRAWING IS A CONTROLLED DOCUMENT.		DWN C.Witt 22FEB2016	 TE Connectivity	
DIMENSIONS: mm		CHK C.Witt 22FEB2016		
TOLERANCES UNLESS OTHERWISE SPECIFIED:		APVD G.Stegmayer 22FEB2016	NAME HAND TOOL HD20 HANDZANGE HD20	
		PRODUCT SPEC -	-	
MATERIAL		APPLICATION SPEC -	-	
FINISH		WEIGHT 280 g	SIZE A3	CAGE CODE 00779
-		CUSTOMER DRAWING	DRAWING NO C-169341-1	RESTRICTED TO
-		SCALE 1:1	SHEET 1 OF 1	REV D1