

4

3

2

1

THIS DRAWING IS UNPUBLISHED.

RELEASED FOR PUBLICATION

20

© COPYRIGHT 20

BY TYCO ELECTRONICS CORPORATION. ALL INTERNATIONAL RIGHTS RESERVED.

LOC  
GP

DIST  
00

REVISIONS

P	LTR	DESCRIPTION	DATE	DWN	APVD
	A	RELEASED	18AUG2010	RG	DO

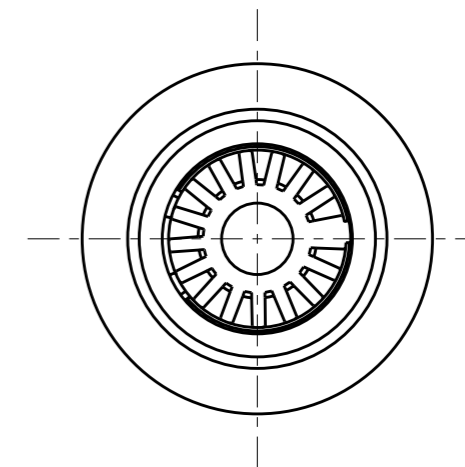
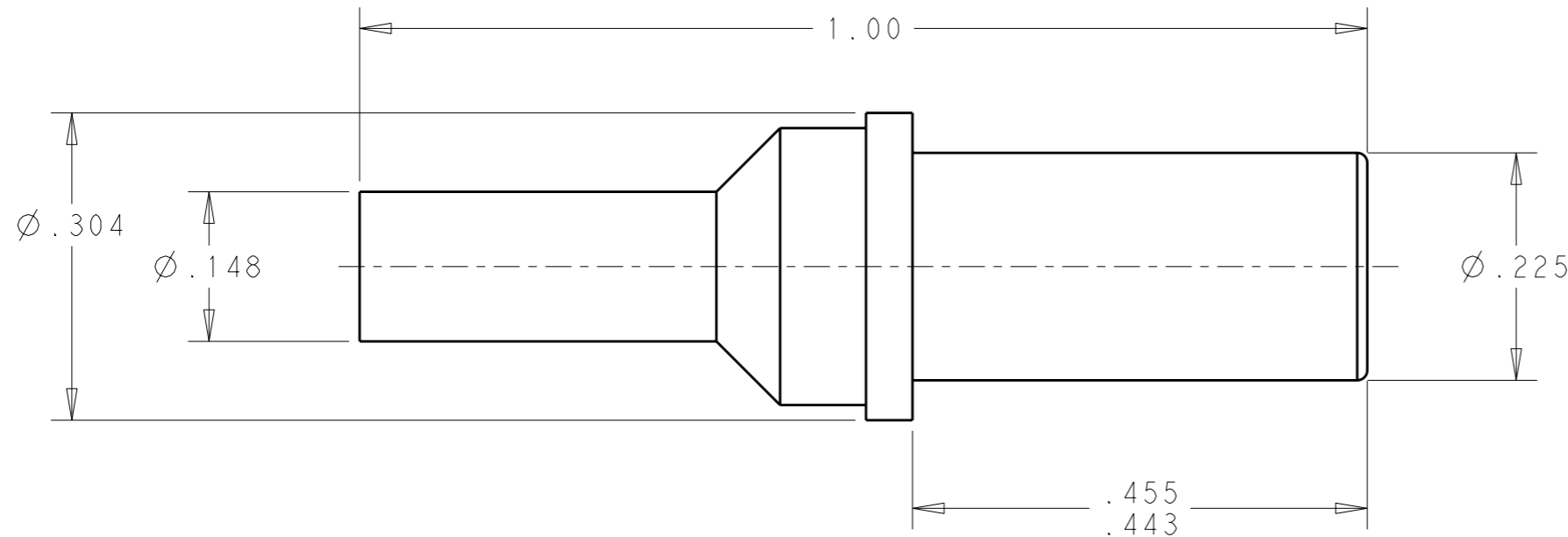

1 MATERIAL:  
 BODY: COPPER ALLOY  
 CROWN BAND: BERYLLIUM COPPER

2 FINISH:  
 BODY: NICKEL PLATE .000040 MIN THK.  
 CROWN BAND: GOLD PLATE .000030 MIN THK. IN CONTACT AREA  
 OVER NICKEL .000040 MIN THK.

3. ITEMS PROVIDED TO THIS SPECIFICATION TO BE PERMANENTLY IDENTIFIED ON THE CONTAINER PER THE FOLLOWING IDENTIFIER:

1648295-1  
 PART NUMBER

TYCO ELECTRONICS P/N      YEAR 1 WEEK 1  
 \_\_\_\_\_      DATE CODE (eg. 0216)  
 XXXXXXX-X      XXXX

<small>THIS DRAWING IS A CONTROLLED DOCUMENT FOR TYCO ELECTRONICS CORPORATION          IT IS SUBJECT TO CHANGE AND THE CONTROLLING ENGINEERING ORGANIZATION          SHOULD BE CONTACTED FOR THE LATEST REVISION.</small>		DWN 18AUG2010 R.GRZYBOWSKI CHK 18AUG2010 D.ORRIS APVD 18AUG2010 M.PERCHERKE	Tyco Electronics Corporation Harrisburg, PA 17105-3608
DIMENSIONS: INCHES 	TOLERANCES UNLESS OTHERWISE SPECIFIED: 0 PLC ±- 1 PLC ±- 2 PLC ±.02 3 PLC ±.010 4 PLC ±- ANGLES ±-	NAME CONTACT, SOCKET, SIZE NO.8 WITH SIZE NO.12 CRIMP BARREL	SIZE A3 CAGE CODE 00779 DRAWING NO C-1648295 RESTRICTED TO -
MATERIAL 1	FINISH 2	WEIGHT - CUSTOMER DRAWING	SCALE 6:1    SHEET 1 OF 1    REV A