

THIS DRAWING IS UNPUBLISHED. RELEASED FOR PUBLICATION APR ,2003.

© COPYRIGHT 2003 By -

ALL RIGHTS RESERVED.

LOC GP DIST 00

REVISIONS

P	LTR	DESCRIPTION	DATE	DWN	APVD
L		REVISED PER ECO-17-012925	21FEB2018	AP	DG

- 1 MATERIAL
HOUSING : THERMOPLASTIC, UL94V-0, BLACK
CONTACTS : PHOSPHOR BRONZE
SHELL : STEEL
SCREW : BRASS.
BOARD LOCK : BRASS.
SCREW OF TORQUE : 5 Kg-cm MAX.
- 2 FINISH
CONTACT : 15µ" MIN.GOLD PLATING ON CONTACT AREA
100µ" MIN. TIN PLATING ON SOLDER TAILS
50µ" MIN. NICKEL UNDERPLATED OVERALL
SHELL : 100µ" MIN NICKEL PLATING
SCREW : 50µ" MIN. NICKEL PLATING.
BOARD LOCK : 50µ" MIN. NICKEL PLATING.
- 3 CHARACTERISTICS
CURRENT RATING : 3A
INSULATION RESISTANCE : 1000MOHMS MIN, 500VDC FOR 2MINS.
TEMPERATURE RATING : -55DEGC ~ +105DEGC
VOLTAGE RATING : 250VDC

4 OBSOLETE PARTS: OBSOLETE CIS STREAMLINING PER D.RENAUD/D.SINISI.

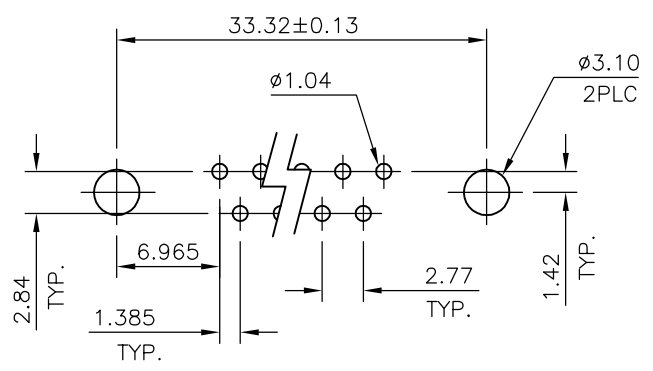
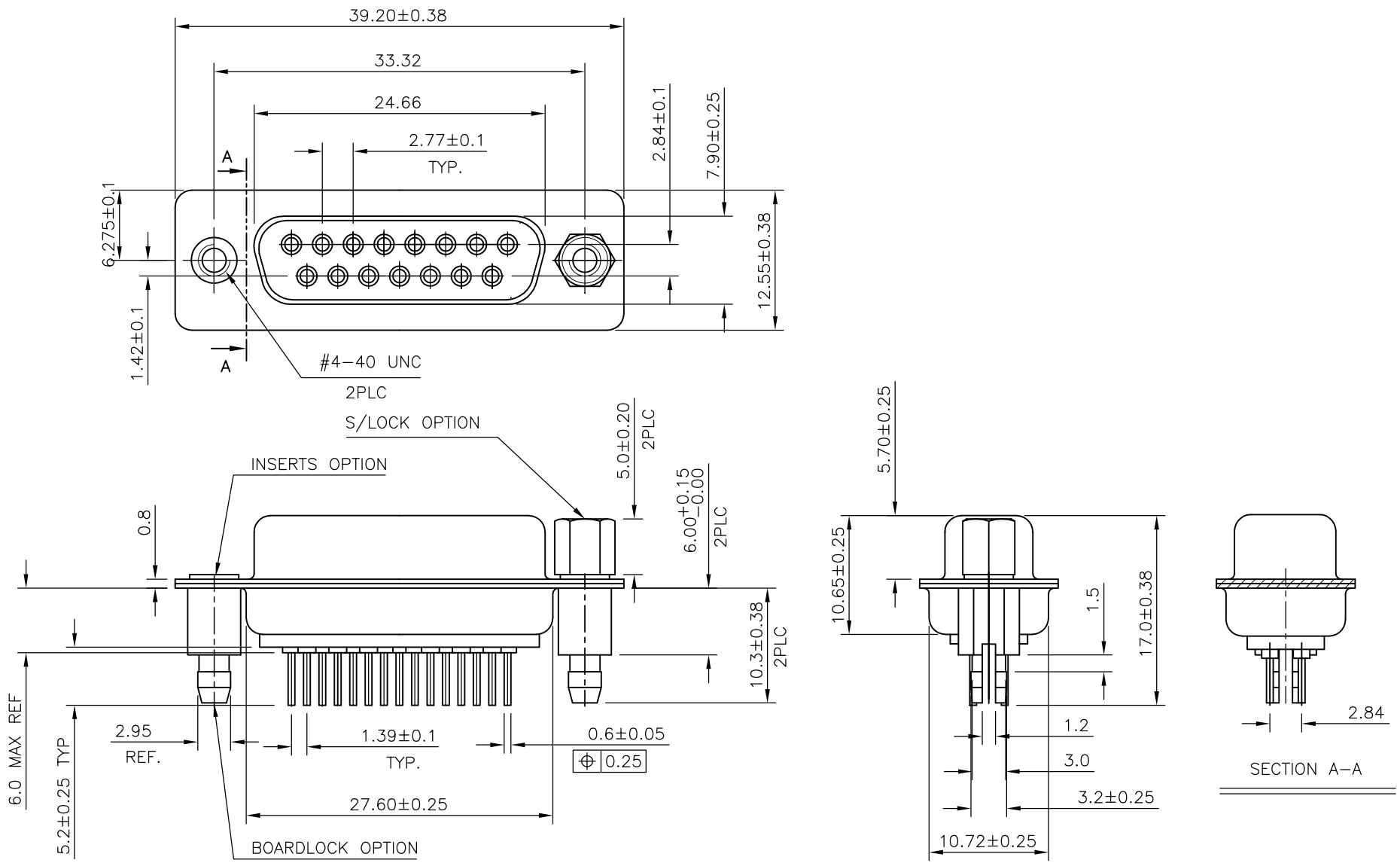

RECOMMENDED PCB LAYOUT(TOP VIEW) (PCBTOLERANCE : ±0.05)

DESCRIPTION	TE PART NO.
OBSOLETE 15W D SKT WITH B/L & M3 S/LOCK 15µ" GOLD	4-1634223-2
SUPERSEDED BY 2301840-1 15W D SKT WITH B/L & 4-40 S/LOCK 15µ" GOLD	3-1634223-2
4 OBSOLETE 15W D SKT WITH B/L & M3 INSERTS 15µ" GOLD	2-1634223-2
OBSOLETE 15W D SKT WITH B/L & 4-40 INSERTS 15µ" GOLD	1-1634223-2

THIS DRAWING IS A CONTROLLED DOCUMENT.		DWN J.SANDWELL 10APR03	STE TE Connectivity	
DIMENSIONS: mm		CHK R.DYER 10APR03		
TOLERANCES UNLESS OTHERWISE SPECIFIED:		APVD F.WHEELER-KING 10APR03	NAME D-SUB HD20, VERTICAL, 15P SKT CONNECTOR	
0 PLC ± -		PRODUCT SPEC -	APPLICATION SPEC -	
1 PLC ± 0.25		WEIGHT -	SIZE A3	CAGE CODE 00779
2 PLC ± 0.15		DRAWING NO C-1634223		RESTRICTED TO -
3 PLC ± -		CUSTOMER DRAWING		
4 PLC ± -		SCALE 2:1	SHEET 1 OF 2	REV L
ANGLES ± -				
FINISH -				

4

3

2

1

THIS DRAWING IS UNPUBLISHED.

RELEASED FOR PUBLICATION APR ,2003.

© COPYRIGHT 2003 By -

ALL RIGHTS RESERVED.

LOC GP DIST 00

REVISIONS

P	LTR	DESCRIPTION	DATE	DWN	APVD
-	-	SEE SHEET 1	-	-	-

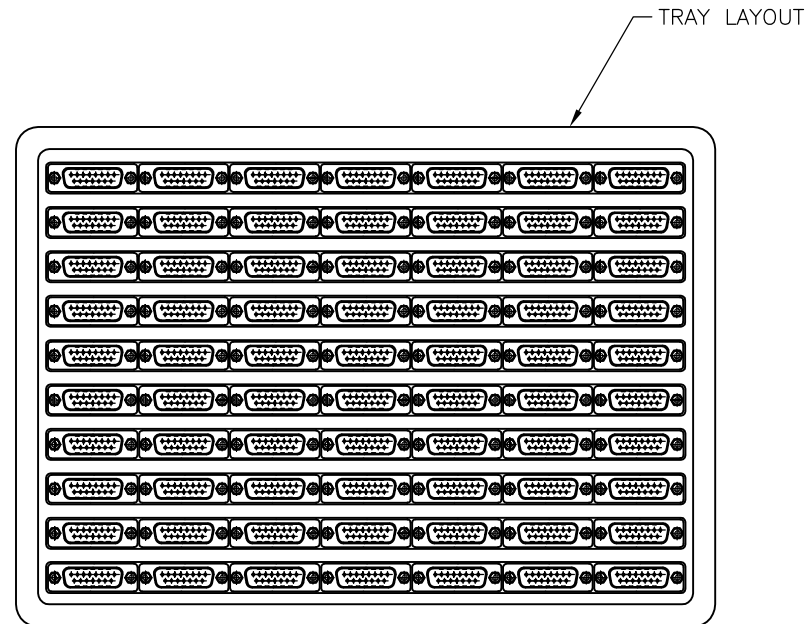
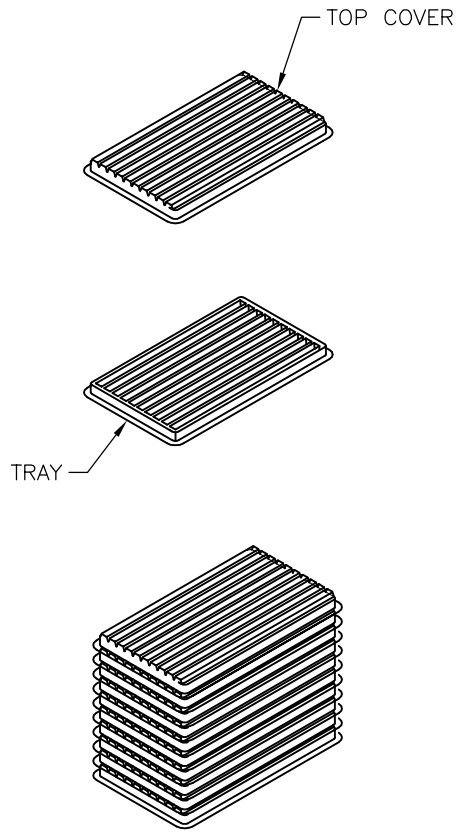

MATERIAL
 1 TRAY: PVC
 2 SHIPPING CARTON: CORRUGATED FIBERBOARD

DIMENSIONS
 1 TRAY: L=310, W=230, H=21
 2 SHIPPING CARTON: L=330, W=245, H=160

QUANTITY
 70 PCS/TRAY
 10 TRAY/SHIPPING CARTON

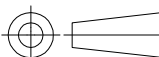
THIS DRAWING IS A CONTROLLED DOCUMENT.		DWN J.SANDWELL 10APR03	 TE Connectivity		
DIMENSIONS: mm		CHK R.DYER 10APR03			
		APVD F.WHEELER-KING 10APR03	NAME D-SUB HD20, VERTICAL, 15P SKT CONNECTOR		
TOLERANCES UNLESS OTHERWISE SPECIFIED: 0 PLC ± - 1 PLC ± 0.25 2 PLC ± 0.15 3 PLC ± - 4 PLC ± - ANGLES ± -		PRODUCT SPEC -	-		
MATERIAL -		FINISH -	APPLICATION SPEC -	WEIGHT -	RESTRICTED TO -
CUSTOMER DRAWING			SIZE A3	CAGE CODE 00779	DRAWING NO C=1634223
			SCALE 2:1	SHEET 2 OF 2	REV L