

THIS DRAWING IS UNPUBLISHED.

RELEASED FOR PUBLICATION APR ,2003.

LOC GP DIST 00

REVISIONS

© COPYRIGHT 2003 By -

ALL RIGHTS RESERVED.

P	LTR	DESCRIPTION	DATE	DWN	APVD
L		REVISED PER ECO-17-012925	21FEB2018	AP	DG

1 MATERIAL  
 HOUSING : THERMOPLASTIC, UL94V-0, BLACK  
 CONTACTS : BRASS.  
 SHELL : STEEL  
 SCREW : BRASS.  
 BOARD LOCK : BRASS.  
 SCREW OF TORQUE : 5 Kg-cm MAX.

2 FINISH  
 CONTACT : 15µ" MIN.GOLD PLATING ON CONTACT AREA  
 100µ" MIN. TIN PLATING ON SOLDER TAILS  
 50µ" MIN. NICKEL UNDERPLATED OVERALL  
 SHELL : 100µ" MIN NICKEL PLATING.  
 SCREW : 50µ" MIN. NICKEL PLATING.  
 BOARD LOCK : 50µ" MIN. NICKEL PLATING.

3 CHARACTERISTICS  
 CURRENT RATING : 3A  
 INSULATION RESISTANCE : 1000MOHMS MIN, 500VDC FOR 2MINS.  
 TEMPERATURE RATING : -55DEGC ~ +105DEGC  
 VOLTAGE RATING : 250VDC

4 OBSOLETE PARTS: OBSOLETE CIS STREAMLINING PER D.RENAUD/D.SINISI.

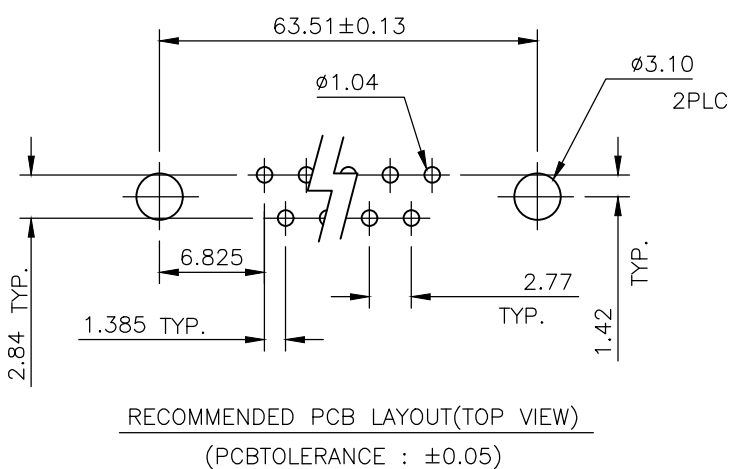
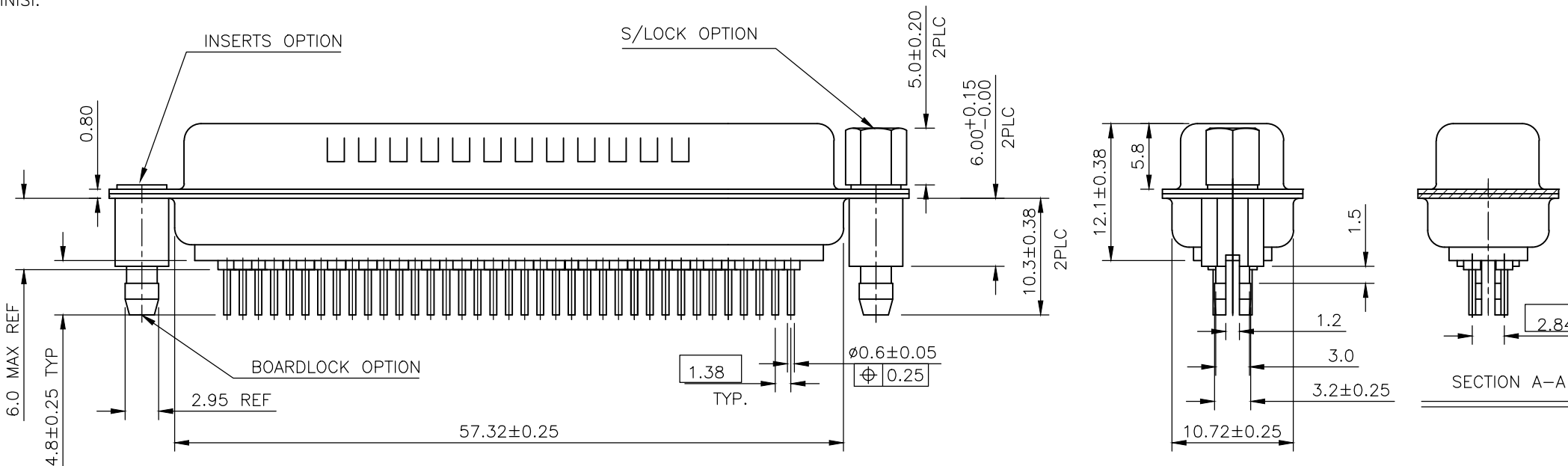
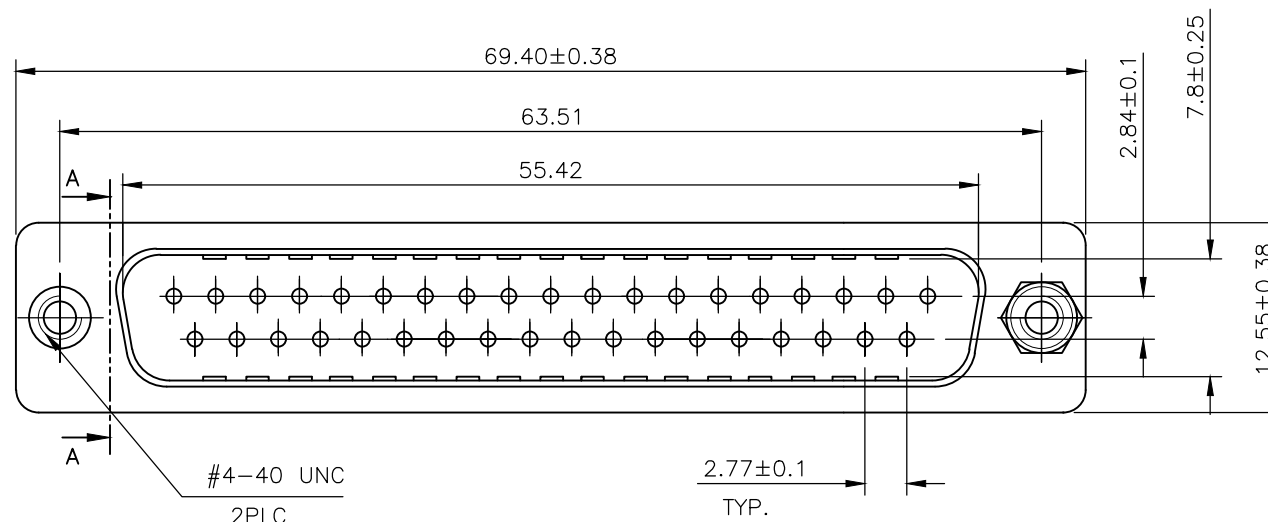

4	OBSOLETE	37W D PLG WITH B/L & M3 S/LOCK 15µ" GOLD	4-1634221-2
SUPERSEDED BY 2301836-1			
4	OBSOLETE	37W D PLG WITH B/L & 4-40 S/LOCK 15µ" GOLD	3-1634221-2
4	OBSOLETE	37W D PLG WITH B/L & M3 INSERTS 15µ" GOLD	2-1634221-2
	OBSOLETE	37W D PLG WITH B/L & 4-40 INSERTS 15µ" GOLD	1-1634221-2
		DESCRIPTION	TE PART NO.

THIS DRAWING IS A CONTROLLED DOCUMENT.		DWN J.SANDWELL 10APR03	<b>STE</b> TE Connectivity	
DIMENSIONS: mm		CHK R.DYER 10APR03		
TOLERANCES UNLESS OTHERWISE SPECIFIED:		APVD F.WHEELER-KING 10APR03	NAME	
0 PLC ± -		PRODUCT SPEC	D-SUB HD20, VERTICAL, 37P PLUG CONNECTOR	
1 PLC ± 0.25		APPLICATION SPEC	-	
2 PLC ± 0.15		WEIGHT	SIZE A3	CAGE CODE 00779
3 PLC ± -		CUSTOMER DRAWING	DRAWING NO	G-1634221
4 PLC ± -			RESTRICTED TO	-
ANGLES ± 3°		SCALE	2:1	SHEET 1 OF 2
FINISH		REV	L	

THIS DRAWING IS UNPUBLISHED.

RELEASED FOR PUBLICATION APR , 2003.

© COPYRIGHT 2003 By -

ALL RIGHTS RESERVED.

LOC	DIST	REVISIONS					
GP	00	P	LTR	DESCRIPTION	DATE	DWN	APVD
		-		SEE SHEET 1	-	-	-

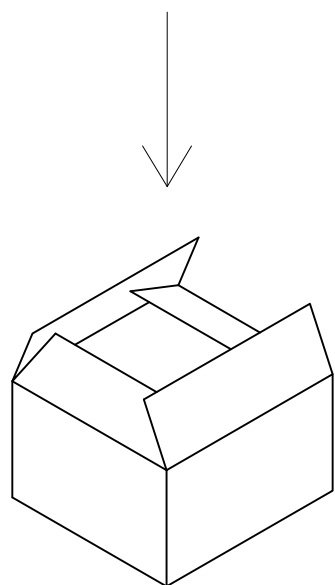
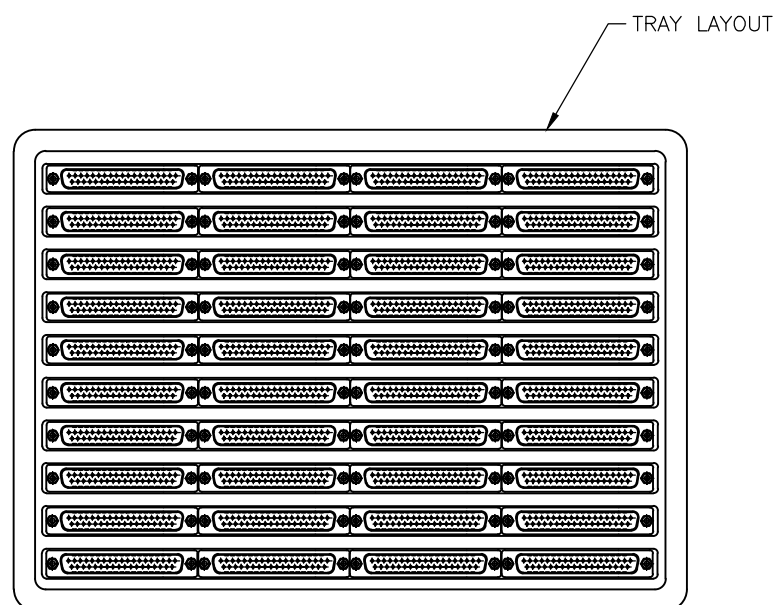
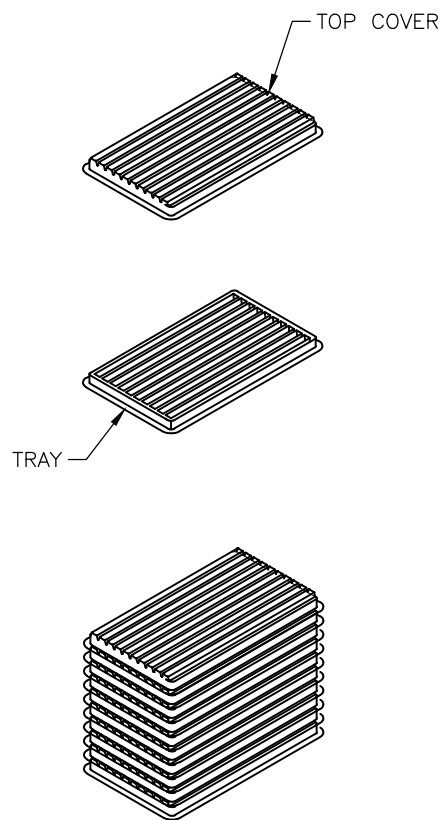

MATERIAL  
 1 TRAY: PVC  
 2 SHIPPING CARTON: CORRUGATED FIBERBOARD

DIMENSIONS  
 1 TRAY: L=310, W=230, H=21  
 2 SHIPPING CARTON: L=330, W=245, H=160

QUANTITY  
 40 PCS/TRAY  
 10 TRAY/SHIPPING CARTON

THIS DRAWING IS A CONTROLLED DOCUMENT.		DWN J.SANDWELL 10APR03	<b>STE</b> TE Connectivity				
DIMENSIONS: mm		CHK R.DYER 10APR03					
TOLERANCES UNLESS OTHERWISE SPECIFIED:		APVD F.WHEELER-KING 10APR03	NAME D-SUB HD20, VERTICAL, 37P PLUG CONNECTOR				
0 PLC ± - 1 PLC ± 0.25 2 PLC ± 0.15 3 PLC ± - 4 PLC ± - ANGLES ± 3°		PRODUCT SPEC -	APPLICATION SPEC -				
MATERIAL -		FINISH -	WEIGHT -	SIZE A3	CAGE CODE 00779	DRAWING NO C-1634221	RESTRICTED TO -
CUSTOMER DRAWING			SCALE 2:1	SHEET 2 OF 2	REV L		