

THIS DRAWING IS UNPUBLISHED.

RELEASED FOR PUBLICATION

20

© COPYRIGHT 20 BY -

ALL RIGHTS RESERVED.

REVISIONS

P	LTR	DESCRIPTION	DATE	DWN	APVD
	0	RELEASED PER 0H14-0474-04	13JUL2004	BY	WB
	A	REV PER ECO-15-016926	23DEC2015	KG	DM

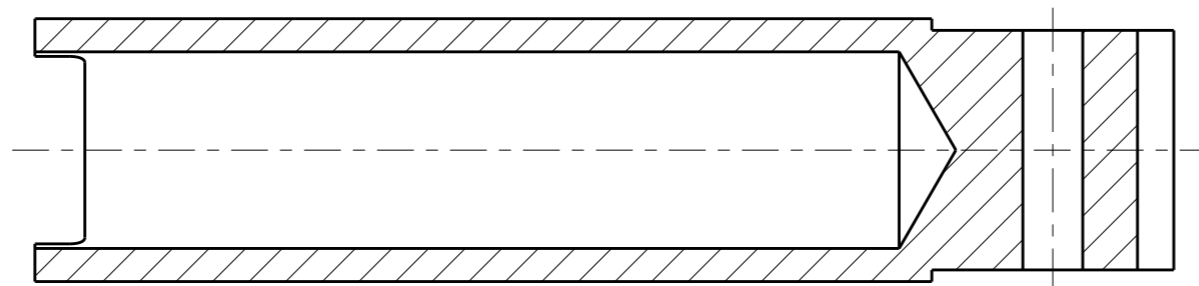

SECTION X - X

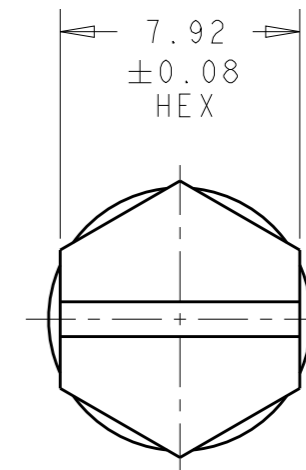
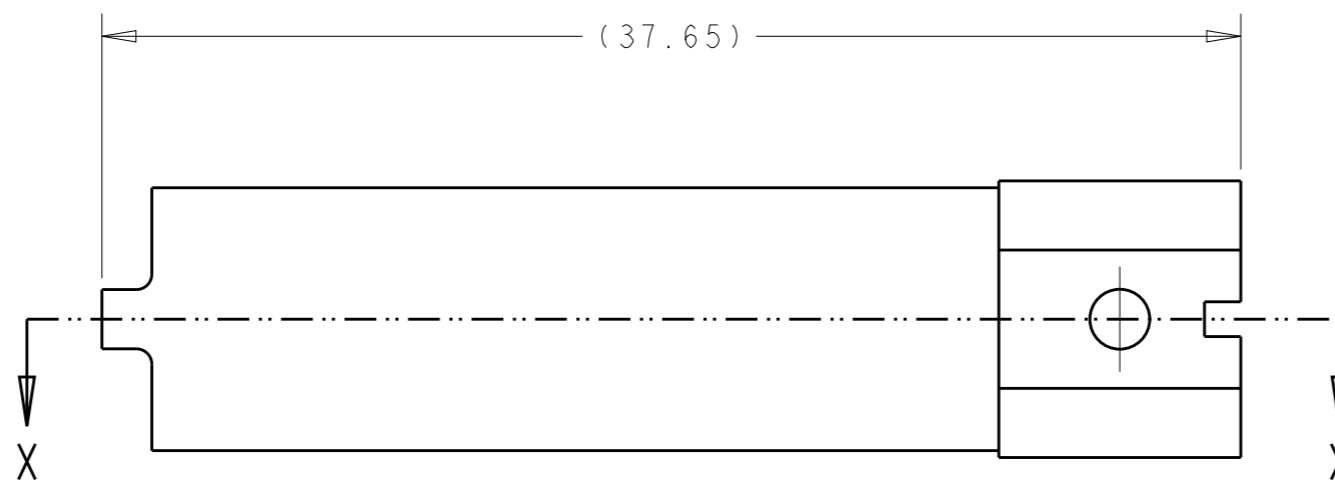
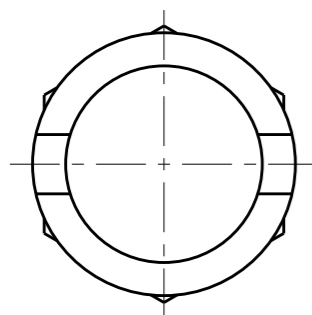

1. MATERIAL: STAINLESS STEEL
FINISH: PASSIVATED

2. TOOL USED FOR ASSEMBLY OF QUADRAX JACKPOST,
TE 1738592-1 AND JACKSCREW TE 2101768-1 IN
RECTANGULAR QUADRAX ASSEMBLIES - SEE
114-13123 FOR FURTHER DETAIL.

AS SHOWN	1604972-1
DESCRIPTION	PART NO.

THIS DRAWING IS A CONTROLLED DOCUMENT.		DWN Brent D. Yohn 13JUL2004	 TE Connectivity	
DIMENSIONS: mm		CHK W.H. BERNHART 13JUL2004		
TOLERANCES UNLESS OTHERWISE SPECIFIED:		APVD W.H. BERNHART 13JUL2004	NAME WRENCH, RETENTION NUT, JACKSCREW AND JACKPOST, QUADRAX RECTANGULAR CONNECTOR	
0 PLC ±-		PRODUCT SPEC	SIZE	
1 PLC ±-		APPLICATION SPEC	CAGE CODE	
2 PLC ±-		WEIGHT	DRAWING NO	
3 PLC ±-		CUSTOMER DRAWING	RESTRICTED TO	
4 PLC ±-			A300779	
ANGLES ±-			C=1604972	
FINISH			SCALE	
SEE NOTE			4:1	
			SHEET	
			1 OF 1	
			REV	
			A	