

THIS DRAWING IS UNPUBLISHED. RELEASED FOR PUBLICATION  
 © COPYRIGHT BY TYCO ELECTRONICS CORPORATION. ALL RIGHTS RESERVED.

LOC	DIST	REVISIONS					
DF	D0	P	LTR	DESCRIPTION	DATE	DWN	APVD
		C		UPDATE PER 0H2Y-0164-04	05-12-04	JDM	MKS

SIZE	(B DIM)	C DIM ±.0050	(L DIM)
05	(.233)	.3085	(.100)
09	(.333)	.4085	(.200)
15	(.483)	.5585	(.350)
25	(.733)	.8085	(.600)
37	(1.033)	1.1085	(.900)
51	(1.383)	1.4585	(1.250)

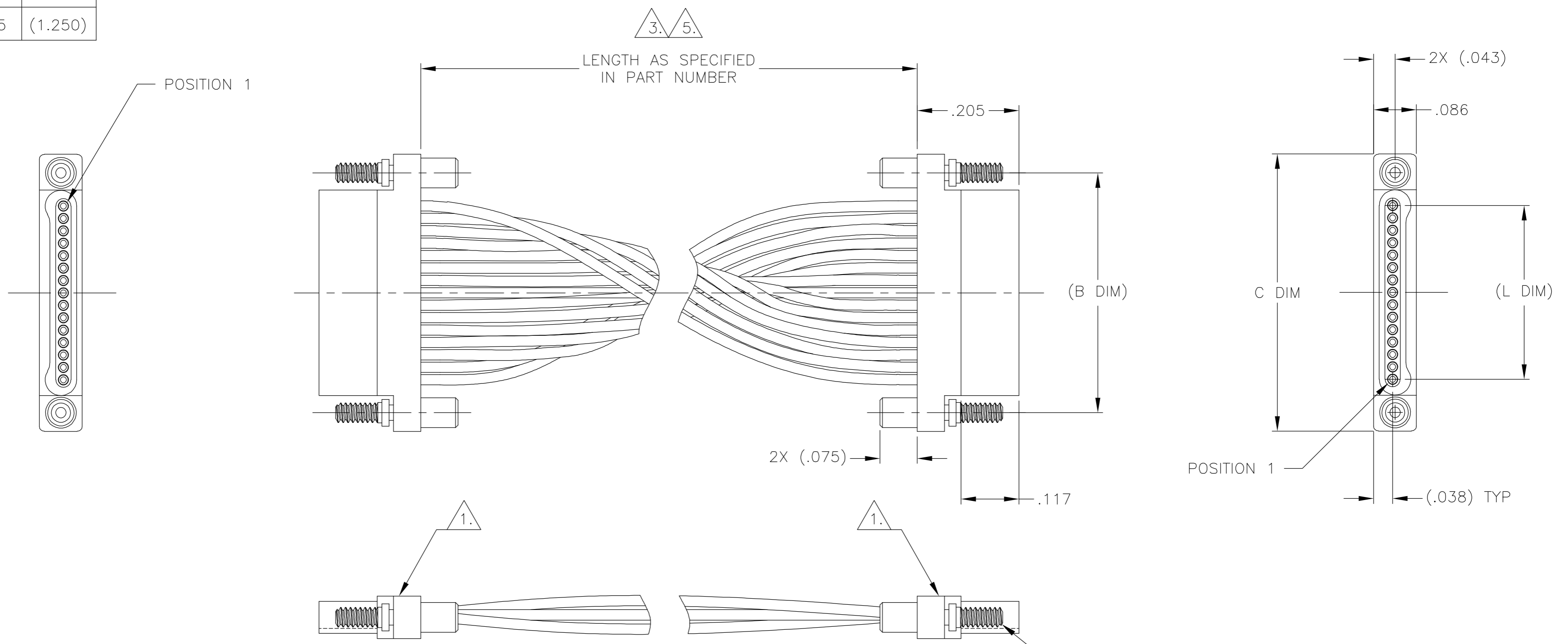

1. SHELL OPTIONS (TO BE SPECIFIED IN NANONICS PART NUMBER):  
 METAL: 6061-T6 ALUMINUM, ELECTROLESS NICKEL PLATED PER MIL-C-26074 (STANDARD) OR GOLD PLATED PER MIL-G-45204  
 303 STAINLESS STEEL, PASSIVATED PER SAE-AMS-QQ-P-35  
 INSULATOR MATERIAL FOR ALL METAL SHELLS IS LIQUID CRYSTAL POLYMER (LCP) PER MIL-M-24519 OR PER ASTM D5138  
 PLASTIC: LIQUID CRYSTAL POLYMER (LCP) PER MIL-M-24519 OR PER ASTM D5138
2. STANDARD 1.00UNM CAPTIVE JACKSCREWS ARE SHOWN FOR REFERENCE ONLY AND MUST BE SPECIFIED IN THE NANONICS PART NUMBER WHEN REQUIRED. JACKSCREW MATERIAL IS 303 STAINLESS STEEL, PASSIVATED PER SAE-AMS-QQ-P-35, AND DRY LUBED PER DOD-L-85645. RETAINING RING IS 17-4 STAINLESS STEEL, PASSIVATED PER SAE-AMS-QQ-P-35. JACKSCREWS HAVE A .9mm HEX SOCKET HEAD. 1.20UNM JACKSCREWS ALSO AVAILABLE.
3. THIS CONFIGURATION MAY BE TERMINATED WITH 28 AWG SOLID, 30 AWG STRANDED, OR SMALLER WIRE. STANDARD WIRING IS 1 TO 1.
4. THIS CONFIGURATION WOULD HAVE THE SAME CONNECTOR TYPE TERMINATED TO EACH END OF THE JUMPER ASSEMBLY.
5. LENGTH TOLERANCE: UP TO 25.0 INCHES,  $\pm .25$ ; 25.0 INCHES AND LONGER,  $\pm 1\%$
6. DIMENSIONS TYPICAL FOR BOTH CONNECTORS.

THIS DRAWING IS A CONTROLLED DOCUMENT.		DWN C SCHOLL 03-19-02	 Tyco Electronics Corporation Harrisburg, PA 17105																		
DIMENSIONS: INCHES		CHK M STORRY 03-21-02																			
TOLERANCES UNLESS OTHERWISE SPECIFIED:		APVD D. MORALES 05-09-03	NAME JUMPER ASSEMBLY, PLUG TO PLUG, SINGLE ROW DUALLOBE, PLASTIC OR METAL																		
<table border="1"> <tr> <td>0 PLC</td> <td>±</td> <td>-</td> </tr> <tr> <td>1 PLC</td> <td>±</td> <td>-</td> </tr> <tr> <td>2 PLC</td> <td>±</td> <td>.010</td> </tr> <tr> <td>3 PLC</td> <td>±</td> <td>.005</td> </tr> <tr> <td>4 PLC</td> <td>±</td> <td>-</td> </tr> <tr> <td>ANGLES</td> <td>±</td> <td>1°</td> </tr> </table>		0 PLC	±	-	1 PLC	±	-	2 PLC	±	.010	3 PLC	±	.005	4 PLC	±	-	ANGLES	±	1°	PRODUCT SPEC -	SIZE A2
0 PLC	±	-																			
1 PLC	±	-																			
2 PLC	±	.010																			
3 PLC	±	.005																			
4 PLC	±	-																			
ANGLES	±	1°																			
MATERIAL SEE NOTES		FINISH SEE NOTES	CAGE CODE 00779																		
		APPLICATION SPEC -	DRAWING NO 1589735																		
		WEIGHT -	RESTRICTED TO -																		
		CUSTOMER DRAWING	SCALE 6:1																		
			SHEET 1 OF 1																		
			REV C																		