

REVISIONS

P	LTR	DESCRIPTION	DATE	DWN	APVD
	B3	ECO-13-000550	10JAN2013	DS	AT
	B3	ECO-14-000116	27FEB2014	DS	AT
	B4	ECN-21-124299	28OCT2021	SS	PK

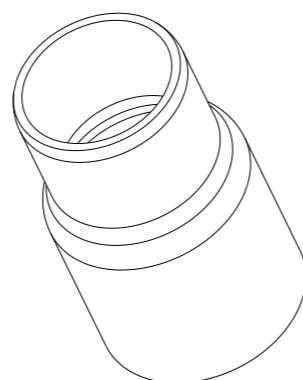
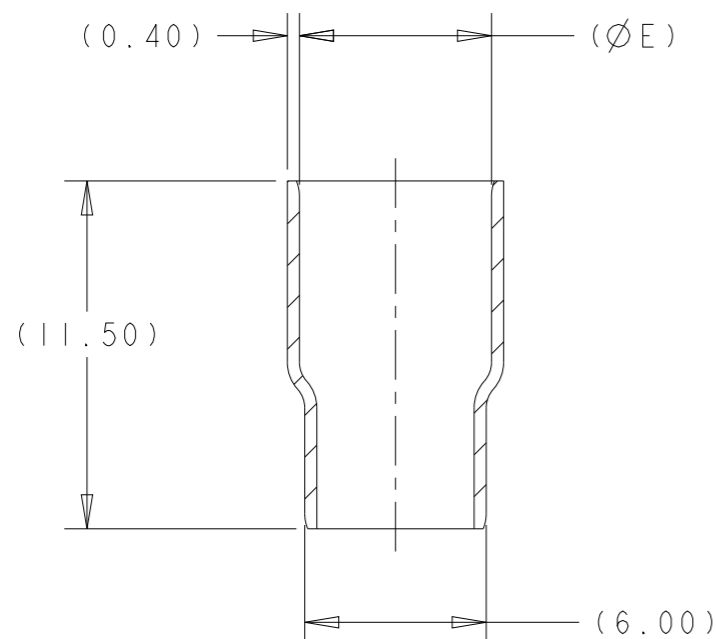

- 1 MATERIAL 1:  
TYPE: COPPER ALLOY
- 2 MATERIAL 2:  
TYPE: ALTERNATE COPPER ALLOY, NO ANNEALING
- 3 FINISH:  
UNDERPLATE TYPE: NICKEL  
TOP PLATE TYPE: TIN
- 4. PARTS MUST BE FREE OF BURRS, CRACKS, OR OTHER VISUAL IMPERFECTIONS THAT MAY AFFECT FIT FORM OR FUNCTION
- 5 NOTE DELETED
- 6 PRELIMINARY PART NOT FOR PRODUCTION

6	2	5.41	6.10	7.70	SIZE C	1-1587829-3
	1	5.41	6.10	7.70	SIZE C	1587829-3
6	2	4.76	5.41	7.00	SIZE B	1-1587829-2
	1	4.76	5.41	7.00	SIZE B	1587829-2
6	2	4.11	4.76	6.40	SIZE A	1-1587829-1
	1	4.11	4.76	6.40	SIZE A	1587829-1
		MIN	MAX		E	DESCRIPTION
		WIRE O.D.				PART NO

THIS DRAWING IS A CONTROLLED DOCUMENT.		DWN D SIMPSON 01JUN2009		
		CHK A TYLER 01JUN2009		
DIMENSIONS: mm	TOLERANCES UNLESS OTHERWISE SPECIFIED:	APVD -	NAME OUTER FERRULE, HVA280	
	0 PLC ±-	PRODUCT SPEC 108-2394	-	
	1 PLC ±0.2	APPLICATION SPEC 114-13259	SIZE A3	CAGE CODE 00779
	2 PLC ±0.10	WEIGHT -	DRAWING NO 1587829	RESTRICTED TO -
	3 PLC ±0.013			
	4 PLC ±0.0001			
MATERIAL - 2 1	FINISH - 3	CUSTOMER DRAWING		
		SCALE 4:1	SHEET 1 OF 1	REV B4