

REVISIONS					
P	LTR	DESCRIPTION	DATE	DWN	APVD
1		NEW PRODUCT	17MAR2008	J.J.	W.M.
A1		ECR-09-010883	13APR2009	J.J.	V.S.
A2		WELDED VERSION REMOVED; DRW. FORMAT UPDATE	02NOV2020	MAH.	SPEG

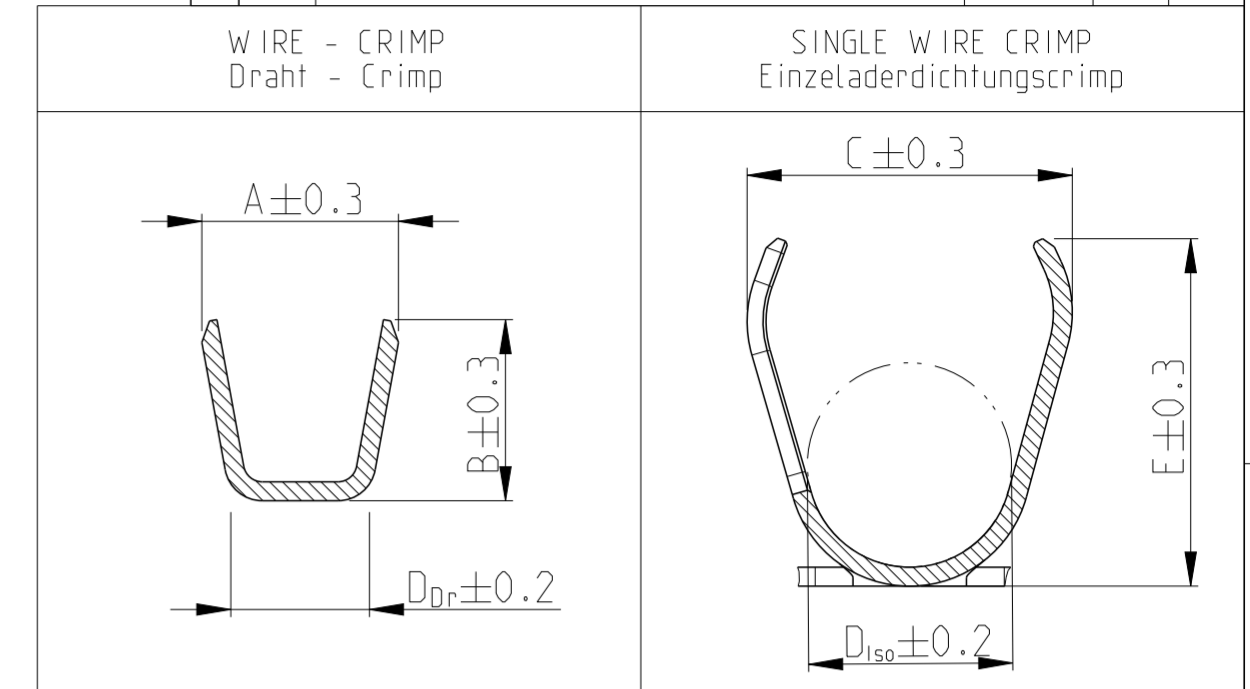

NOTES:  
Bemerkungen:

- ① CONTACT AREA  
Kontaktierungsbereich
- ② SPRING  
Ueberfeder
- ③ FOR WIRE SEE TE-SPEC. 114-18912  
Fuer Leitung siehe TE-Spez. 114-18912 A2
- ④ GOLD PLATED MIN. 2.0 µm Au OVER 1.0-3.5 µm Ni  
(CONTACT AREA TAB ONLY)  
Galvanisch vergoldet min. 2.0 µm Au ueber 1.0-3.5 µm Ni  
(nur Kontaktzone TAB) A2
- ⑤ STAMPED INDICATOR FOR PLATING:  
-AU GOLD PLATING  
Markierung fuer galvanische Ausfuehrung  
-AU vergoldet
- ⑥ TE LOGO; REVISION STATUS; DATE CODE  
TE Logo; Aenderungsstand, Datumscode

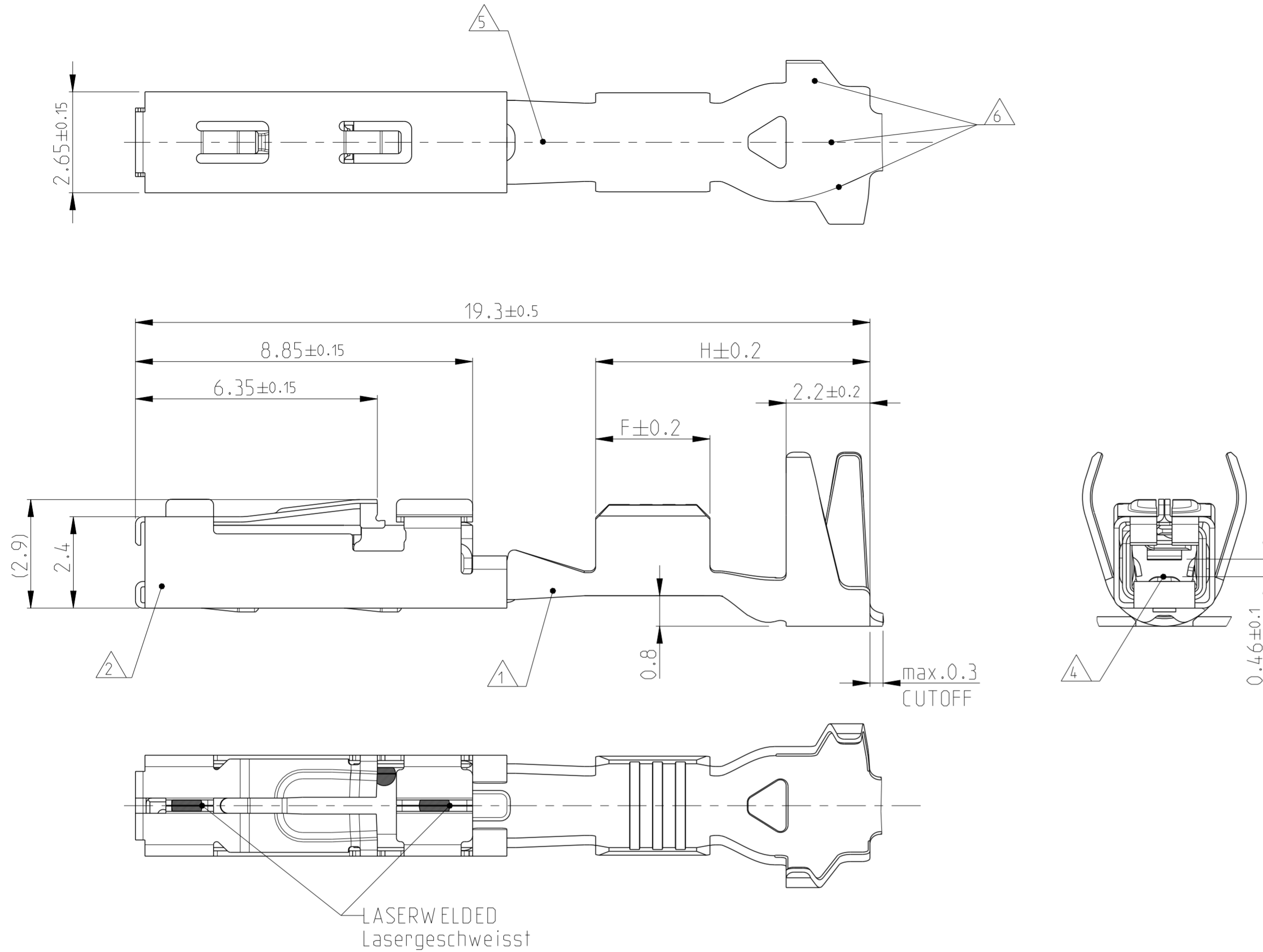
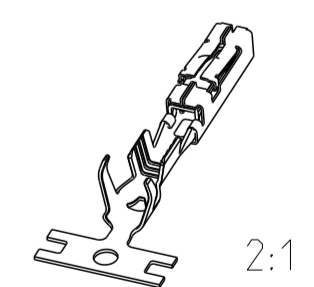

VERSION / Ausfuehrung	ORDER-NO. REELED FORM	REV.	ORDER-NO. LOOSE PIECE	REV.	BODY Kontakt-koerper	SPRING Kontakt-feder	SPRING Kontakt feder	CONTACT AREA TAB Kontaktzone TAB	SURFACE Oberflaeche	WIRE RANGE Draht-groessen-bereich [mm 2]	WIRE CRIMP Drahtcrimp						INSULATION CRIMP Isolationscrimp			F	H	-	-	-	-	Øxxx [mm]	SINGLE WIRE SEAL FOR CAVITY DIAMETER Einzel-dichtung Kammer-Ø; TE Nr.	BLINDPLUG ORDER NO. Blindstopfen Bestell-Nr.
											A	B	D <sub>Dr</sub>	C	E	D <sub>ISO</sub>												
SINGLE WIRE SEAL Einzeladerdichtung	1563621-2	B	1563622-2	B	CuNiSi	X10CrNi18-8		GOLD PLATED vergoldet	0.35	2.0	1.8	1.2	4.3	4.6	2.7	2.5	-	6.7	-	-	964971-1 (Ø3.9)	963531						
	1563623-2	B	1563624-2	B	CuNiSi	X10CrNi18-8		GOLD PLATED vergoldet	0.5	2.2	2.1	1.4	4.3	4.6	2.7	3.0	-	7.2	-	-	964971-1 (Ø3.9)							
	1563625-2	B	1563626-2	B	CuNiSi	X10CrNi18-8		GOLD PLATED vergoldet	0.75-1.0	2.6	2.4	1.8	4.3	4.6	2.7	3.0	-	7.2	-	-	964972-1 (Ø3.9)							

THIS DRAWING IS A CONTROLLED DOCUMENT.		DWN J. Jauris 17MAR2008	 TE Connectivity	NAME HPF-1.5mm Sensorkontakt	
DIMENSIONS: mm		CHK W. Mueller 07APR2008		PRODUCT SPEC 108-94126	
TOLERANCES UNLESS OTHERWISE SPECIFIED: TOL. ACC. DIN ISO 8015		APVD -	APPLICATION SPEC 114-18912 <span style="border: 1px solid black; padding: 2px;">A2</span>		
MATERIAL -		FINISH -	WEIGHT 0.3 g	SIZE A2	CAGE CODE 00779
REELED FORM/Bandware		CUSTOMER DRAWING		SCALE 5:1	SHEET 1 OF 1