

LOC	DIST	REVISIONS					
G	02	P	LTR	DESCRIPTION	DATE	DWN	APVD
			A1	REV ECR-10-004009	24FEB10	JR	TM

1 FOR .105-.140 WIRE INSULATION DIA

2 TONGUE MATERIAL THICKNESS .033

3 APPLIES FROM EDGE OF METAL WIRE BBL TO THE CENTER OF STUD HOLE.

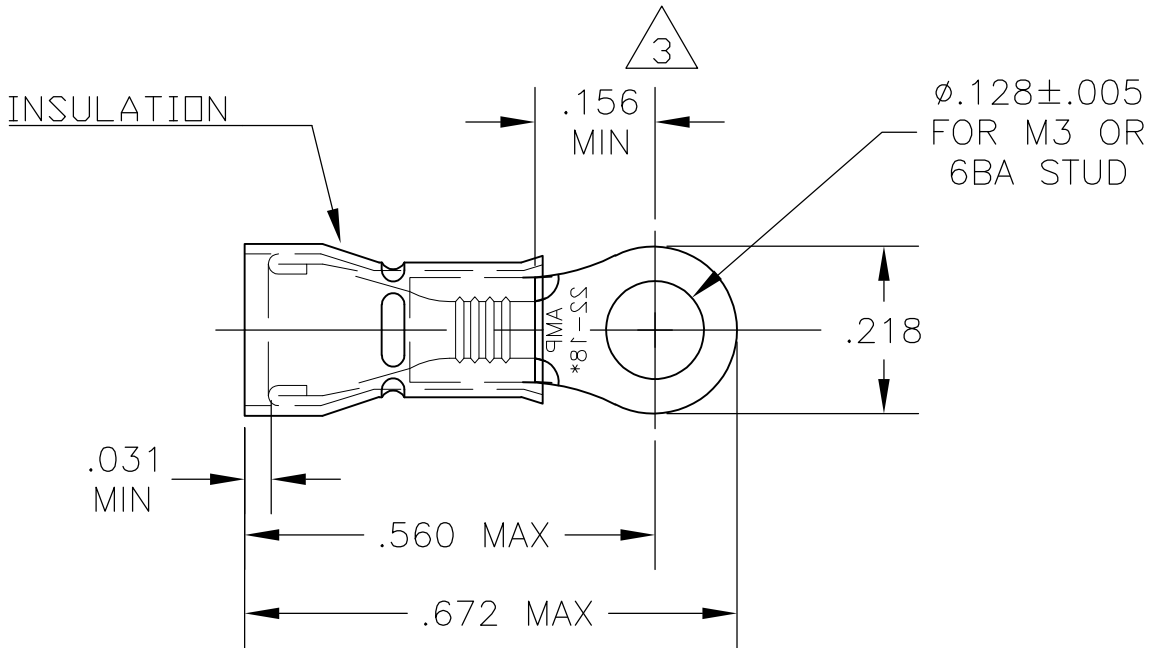

BODY: COPPER, ANNEALED, TIN PLATED
 SLEEVE: COPPER, ANNEALED, TIN PLATED
 INSULATION: NYLON, COLOR-BLACK

151754

MATERIAL & FINISH

PART NO

THIS DRAWING IS UNPUBLISHED.

ALL INTERNATIONAL RIGHTS RESERVED.

BY TYCO ELECTRONICS CORPORATION.

DIMENSIONS:
INCHES

DWN JR RUTH 24FEB10

MATERIAL - FINISH -

FINISH -

TOLERANCES UNLESS OTHERWISE SPECIFIED:

CHK T MICHIELUTTI 24FEB10

Tyco Electronics Tyco Electronics Corporation
 Harrisburg, PA 17105-3608

APVD T MICHIELUTTI 24FEB10

PRODUCT SPEC -

NAME RING TONGUE, PIDG,
WIRE SIZE: 22-16

APPLICATION SPEC -

WEIGHT -

SIZE A4 CAGE CODE 00779 DRAWING NO C-151754 RESTRICTED TO -

CUSTOMER DRAWING

SCALE 4:1 SHEET 1 OF 1 REV A1

