

THIS DRAWING IS UNPUBLISHED. RELEASED FOR PUBLICATION 20
 © COPYRIGHT 20 BY - ALL RIGHTS RESERVED.

REVISIONS					
P	LTR	DESCRIPTION	DATE	DWN	APVD
C3		ECR-15-009282	29JUL2015	KG	DW
D		ECR-19-008989	17JUN2019	TS	DW

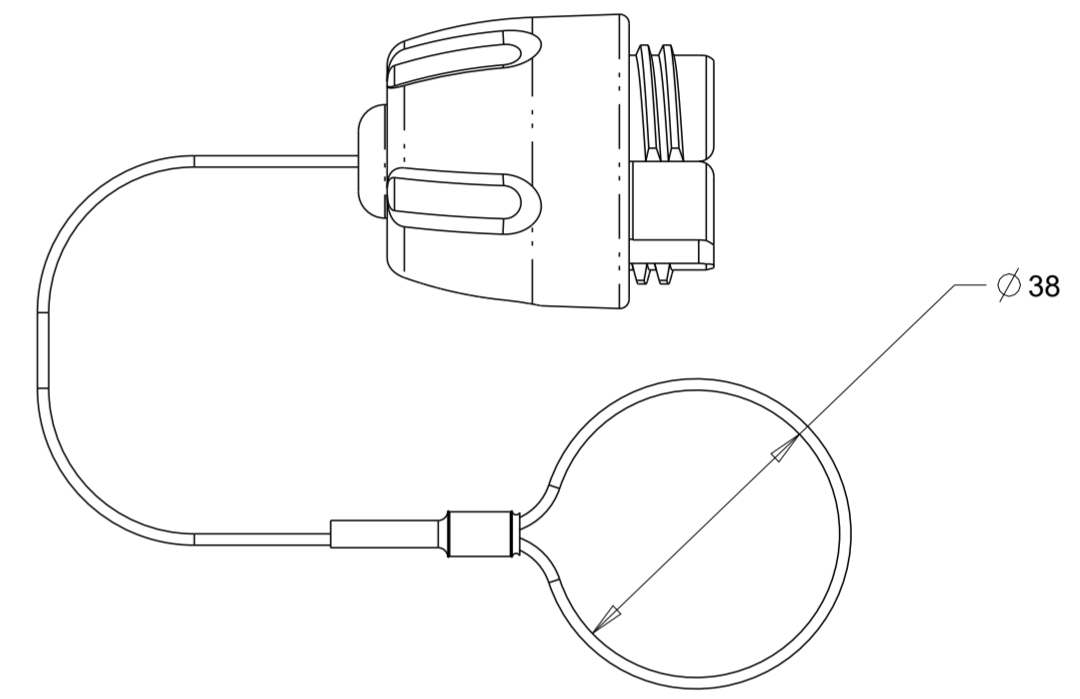
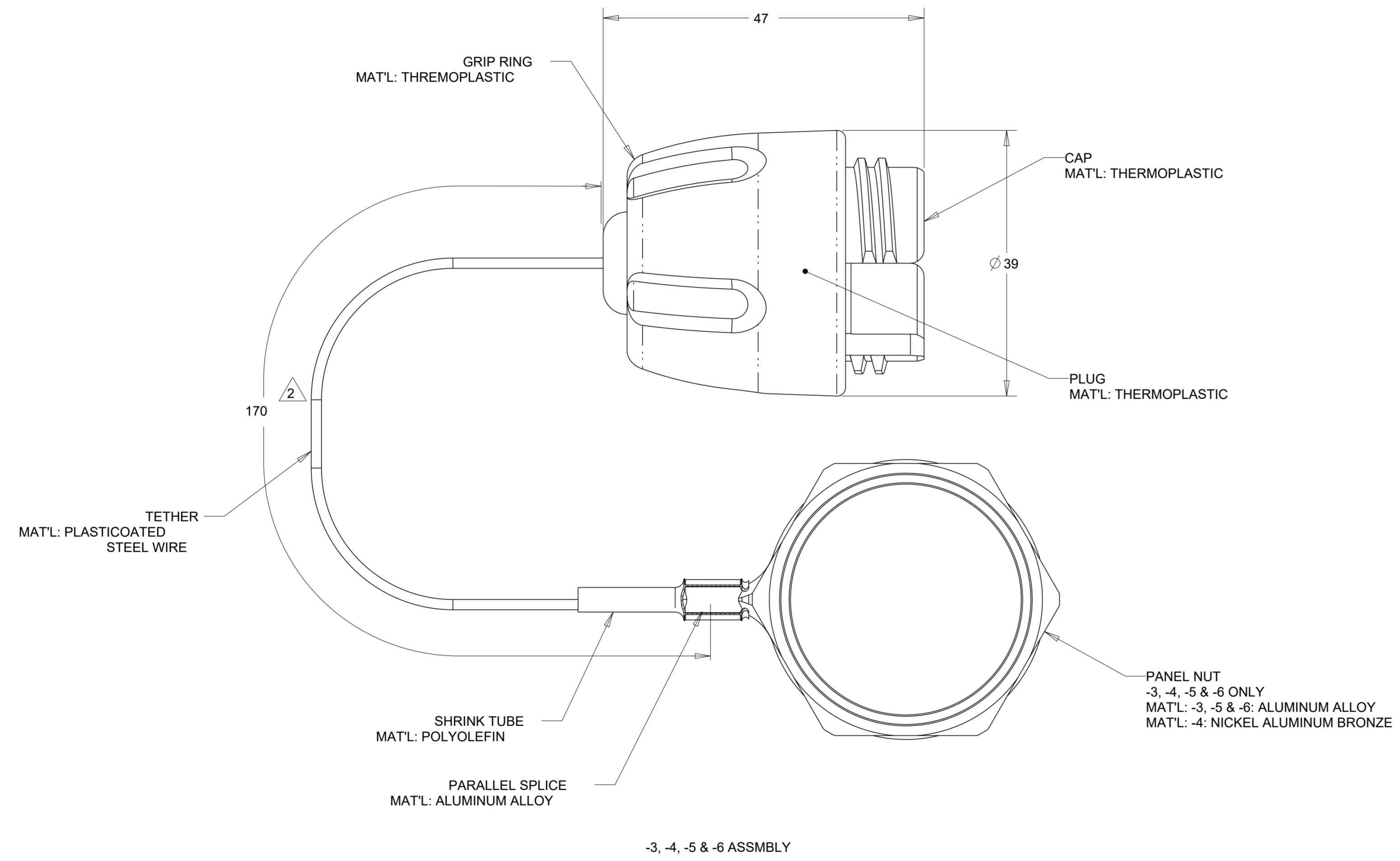

1. DIMENSIONS ARE FOR REFERENCE ONLY.
 2. DIMENSIONED TO CENTER OF PARALLEL SPLICE.

SUPERSEDED BY: 1515726-6	BLACK Zn-Ni ALLOY	1515726-6
	OD GREEN CHROMATE/Zn	1515726-5
	NONE	1515726-4
	HARD ANODIZE	1515726-3
	NOT INCLUDED	1515726-2
	PANEL NUT FINISH	PART NUMBER

THIS DRAWING IS A CONTROLLED DOCUMENT.		DWN K.GLATFELTER 07MAR2005	STE TE Connectivity		
DIMENSIONS: mm		CHK D. WERTMAN 18MAR2005			
TOLERANCES UNLESS OTHERWISE SPECIFIED:		APVD D. WERTMAN 18MAR2005	NAME PROTECTIVE CAP ASSEMBLY, PRO BEAM SR., D-HOLE, BULKHEAD		
0 PLC ±		PRODUCT SPEC	SIZE		
1 PLC ±		APPLICATION SPEC	CAGE CODE		
2 PLC ±		WEIGHT	DRAWING NO		
3 PLC ±		Customer Drawing	RESTRICTED TO		
4 PLC ±			SCALE		
ANGLES ±			SHEET		
FINISH			OF		
MATERIAL AS LISTED			1		
			REV		
			D		