

REVISIONS				
P	LTN	DESCRIPTION	DATE	OWN APVD
D		REVISED PER ECN-22-136865	01FEB2022	RK MZ

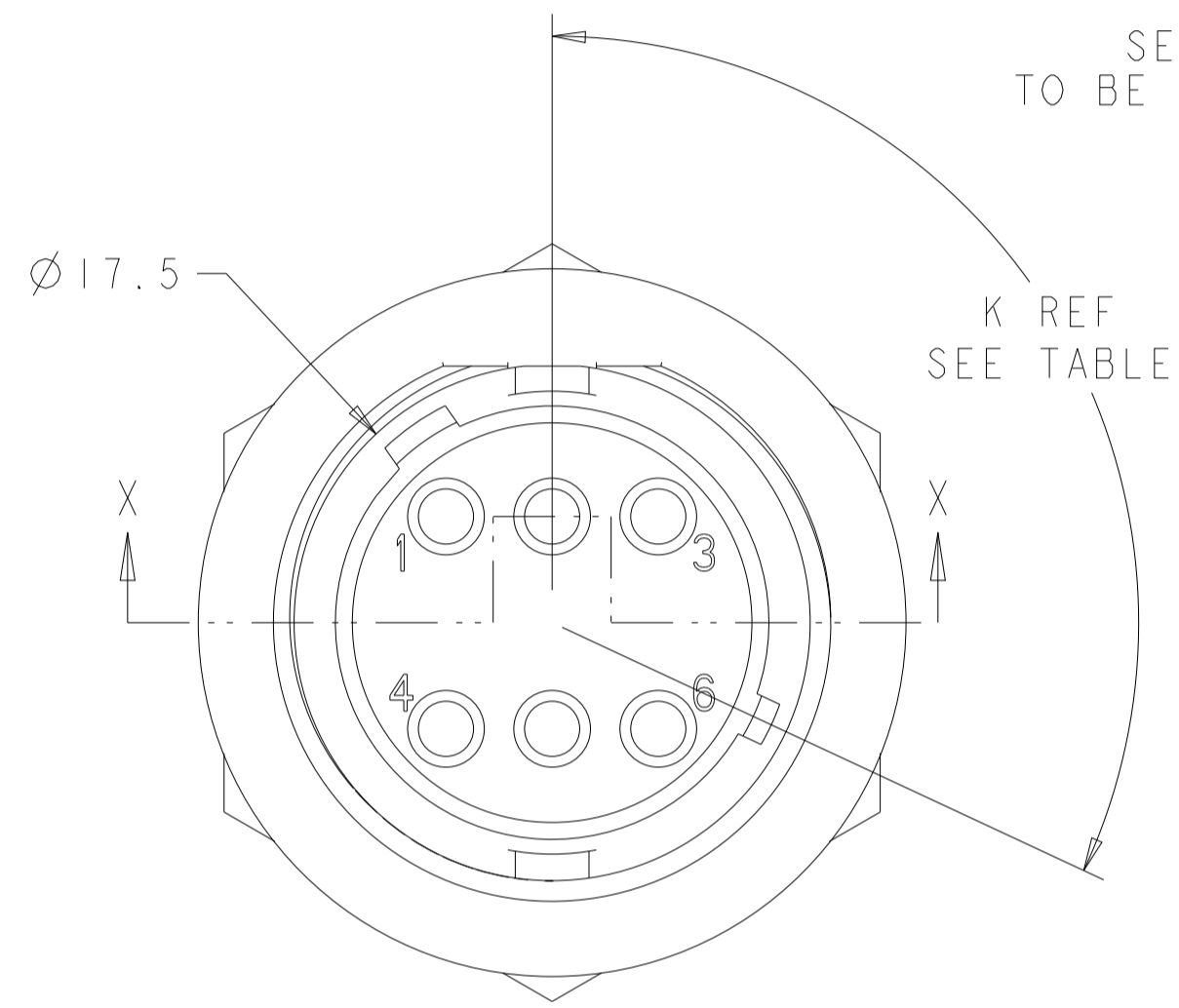

SEAL, PANEL, SHOWN FOR REFERENCE ONLY, TO BE ORDERED SEPARATELY, PART #1445420-02

JAM NUT, SHOWN FOR REFERENCE ONLY, TO BE ORDERED SEPARATELY, PART # 1445904-1

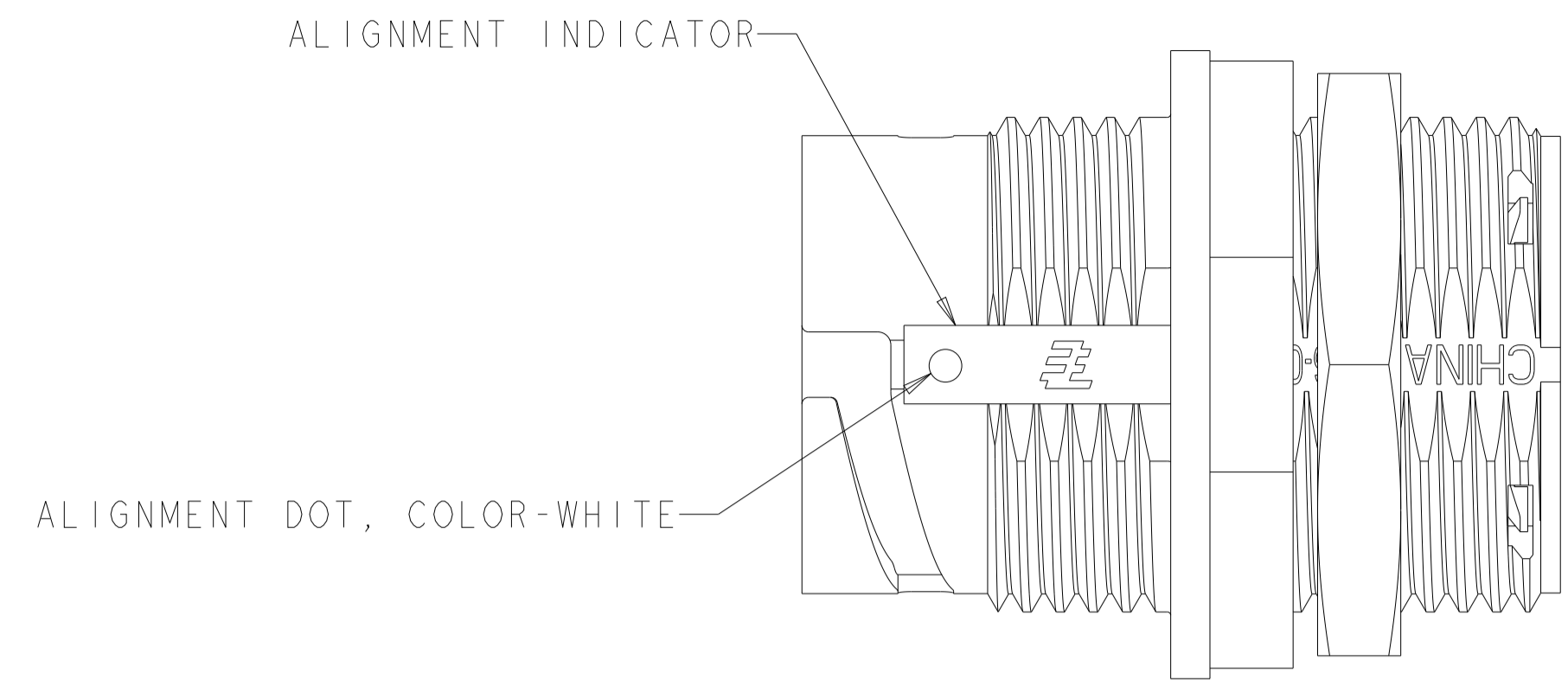
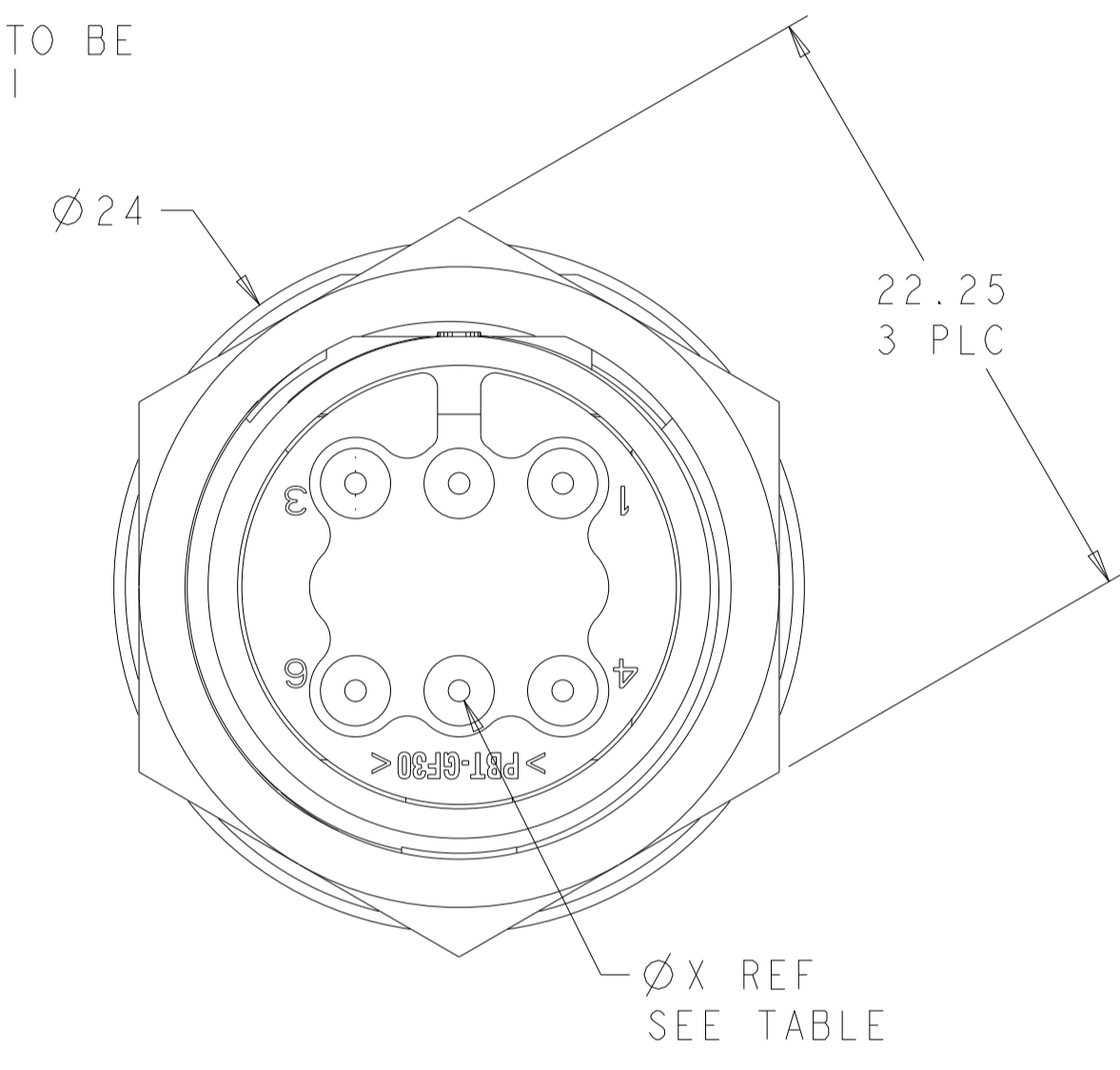
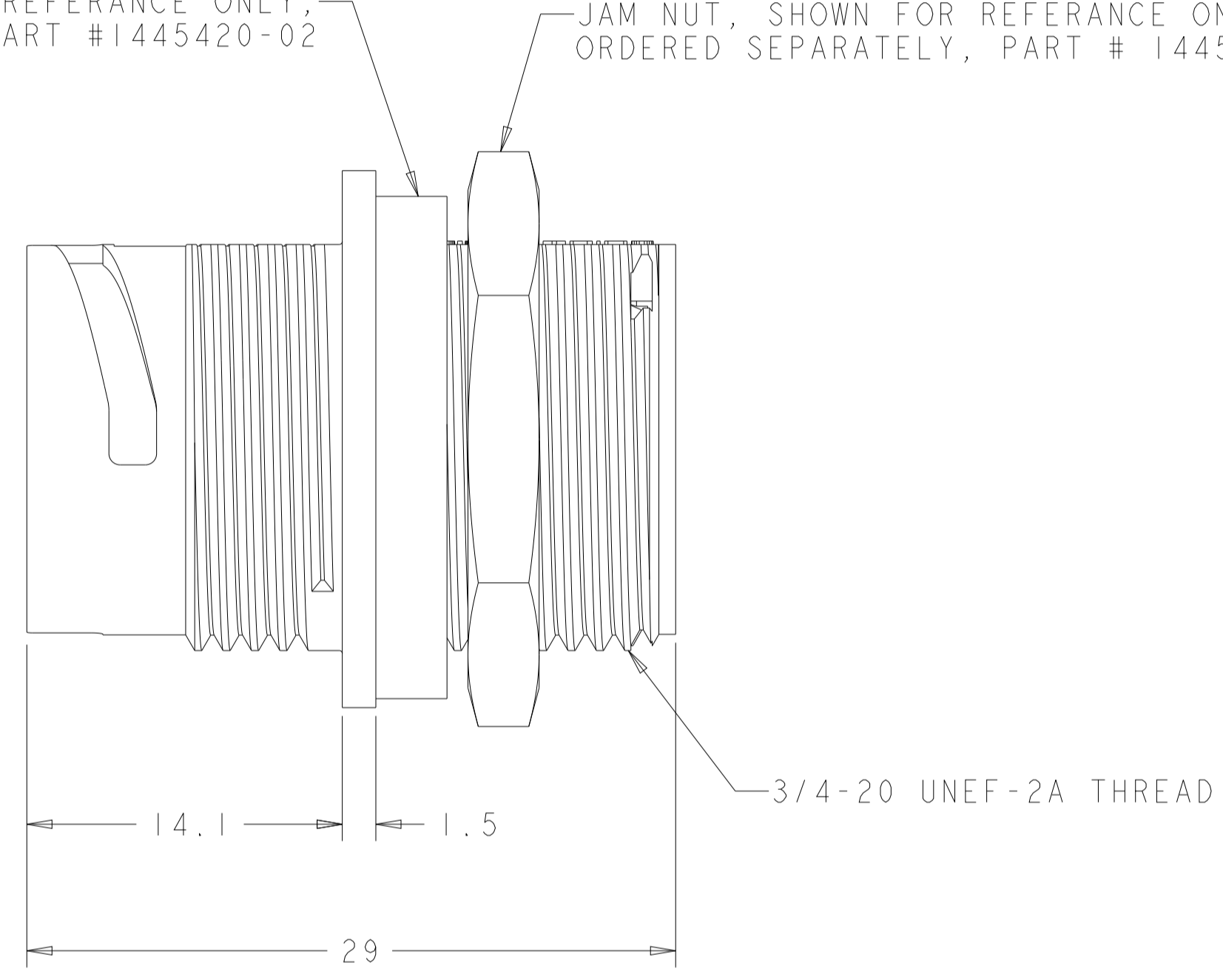

SEAL, PERIPHERAL; QTY-1
 MATERIAL: ELASTOMER, COLOR-BLACK

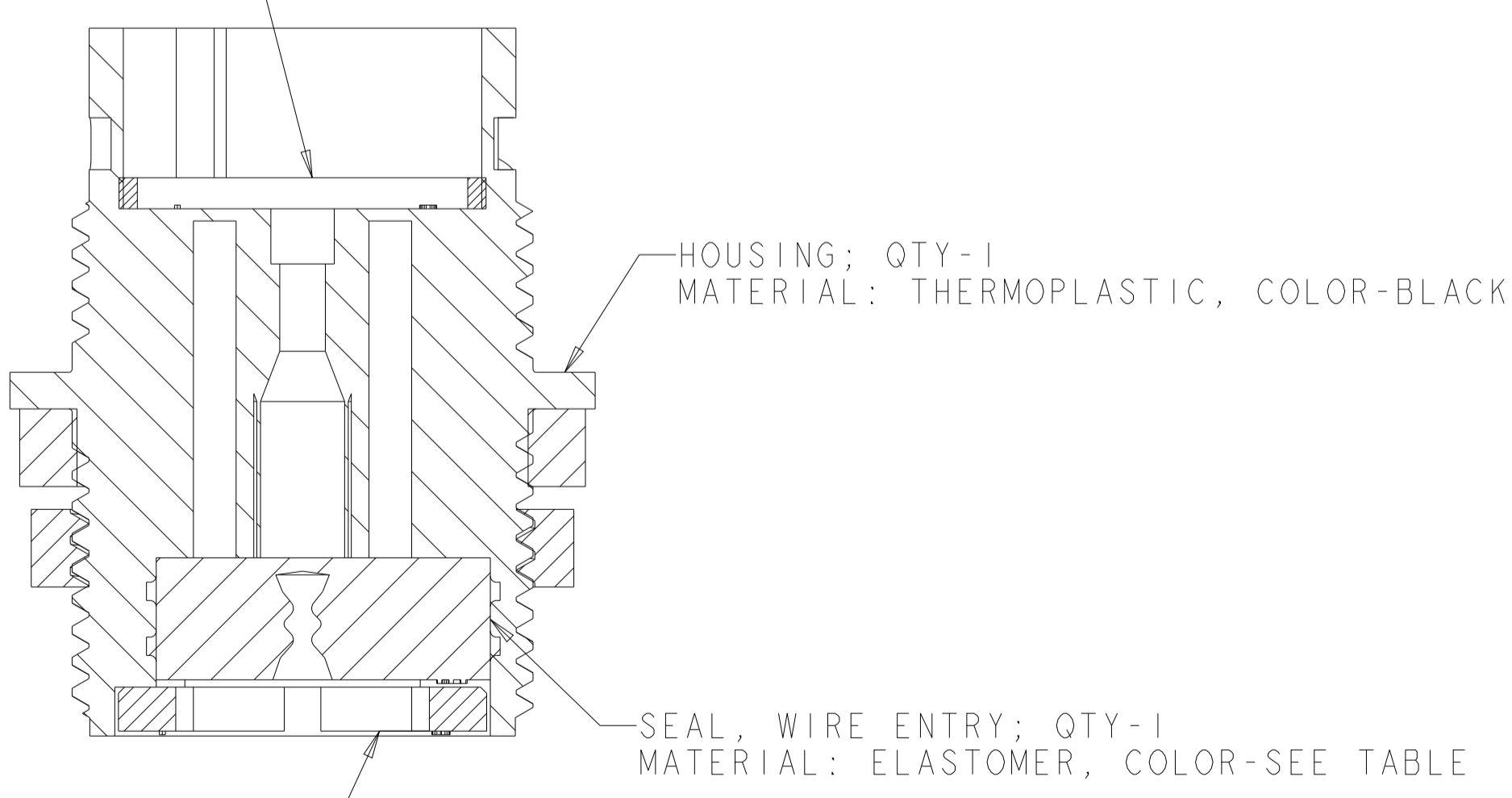

- 1. CONNECTOR CAN BE FRONT OR REAR PANEL MOUNTED.
- 2. MAX PANEL THICKNESS - 3.18

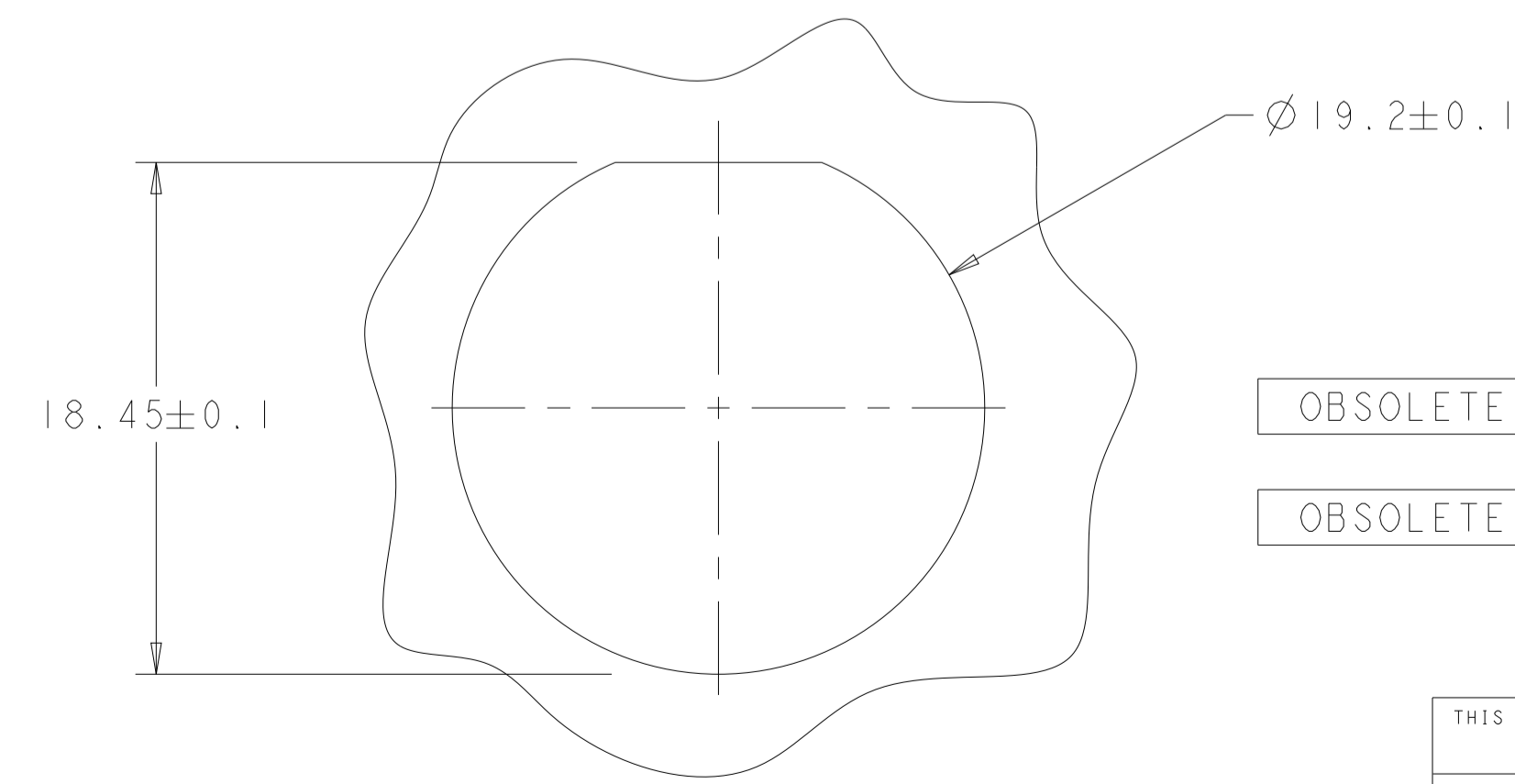

OBSOLETE	YELLOW	Ø 0.75	135°	1445823-04
	NATURAL	Ø 1.5	115°	1445823-03
OBSOLETE	NATURAL	Ø 1.5	135°	1445823-02
	YELLOW	Ø 0.75	115°	1445823-01
	SEAL, WIRE ENTRY COLOR	Ø X REF	K REF	PART NUMBER

THIS DRAWING IS A CONTROLLED DOCUMENT.

OWN: SHANE WUEST 15OCT2001
 CHK: G DOUTY 15OCT2001

APVD: H. WAKEEM 13JUN2003

NAME: ASSEMBLY, RECEPTACLE, SIZE 11, 6 POSITION, PANEL MOUNT, SEALED, MINI CPC

SIZE: A1 CAGE CODE: 100779 DRAWING NO: 1445823

RESTRICTED TO: -

MATERIAL: SEE CALLOUT
 FINISH: SEE CALLOUT

WEIGHT: -
 CUSTOMER DRAWING

SCALE: 4:1 SHEET 1 OF 1 REV D

TE Connectivity