

LOC		DIST		REVISIONS			
				REV	DATE	BY	APPV
1	N	00					

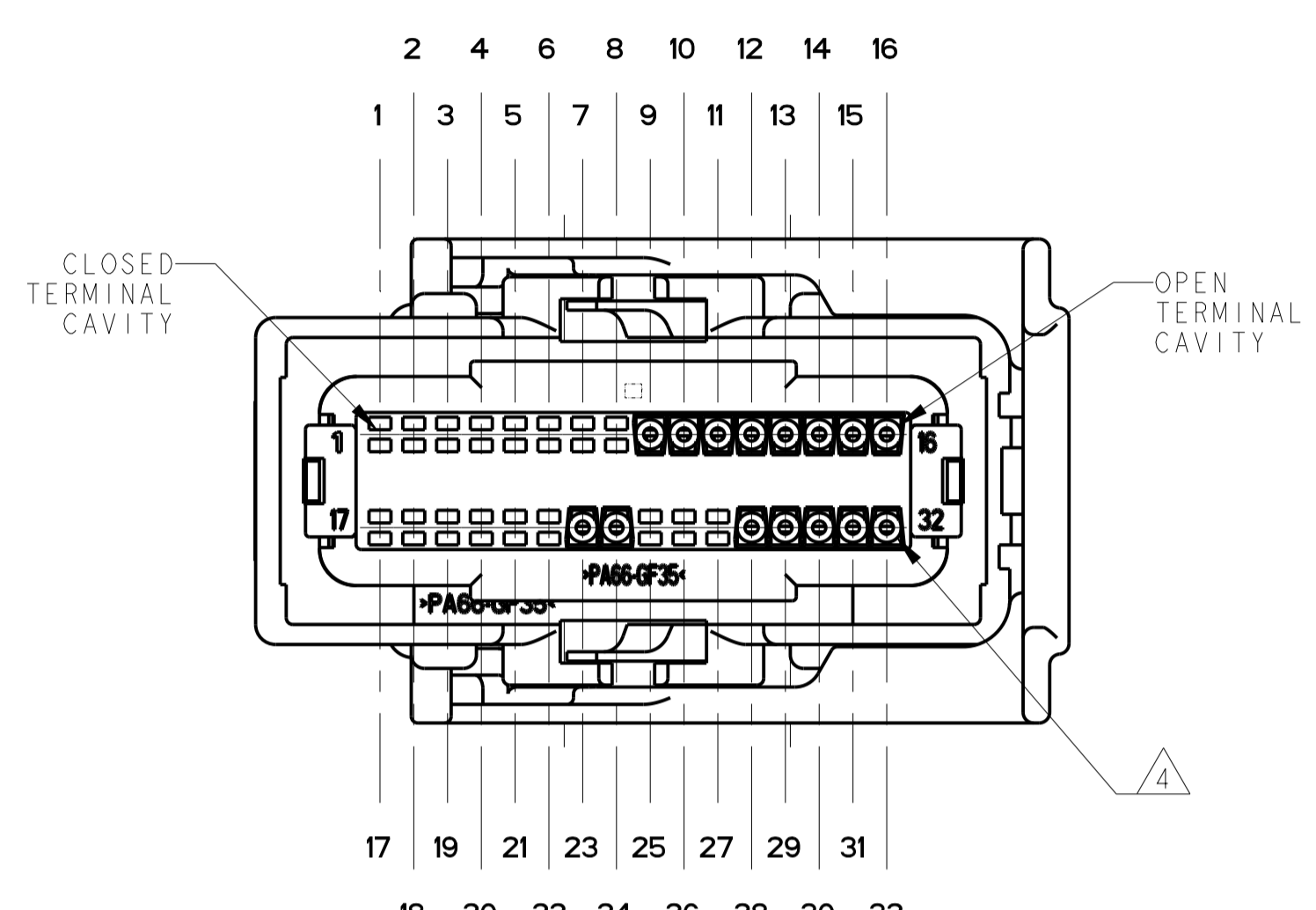

PART NUMBER: 1-1438640-1 SHOWN
 FOR REFERENCE ONLY

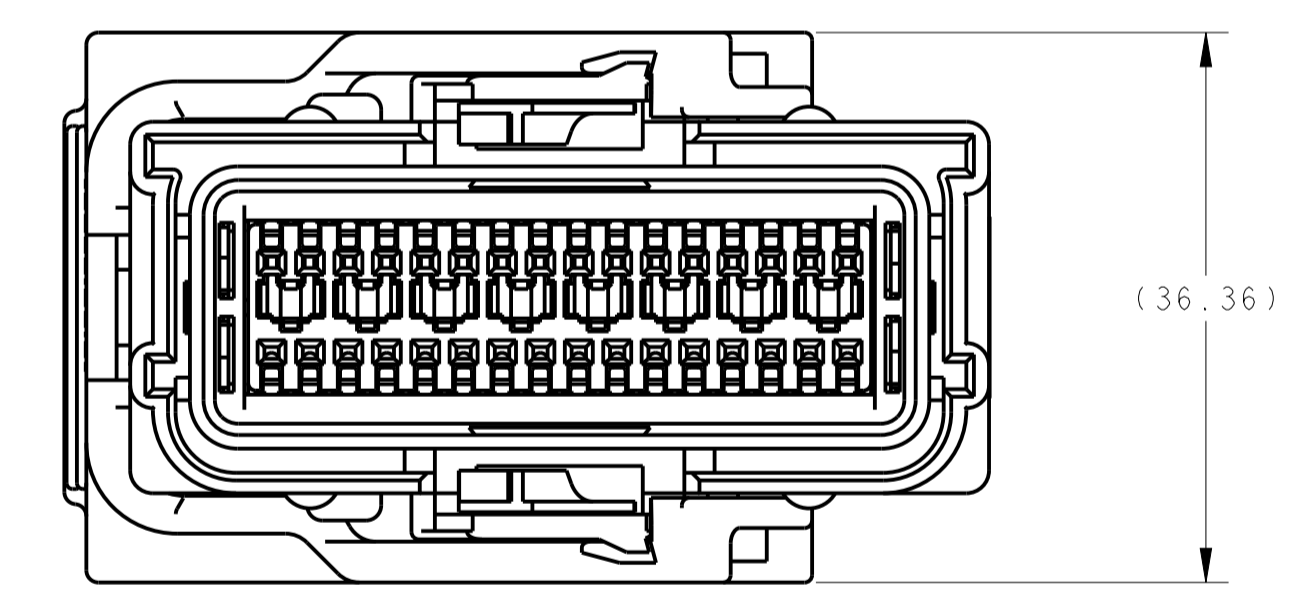
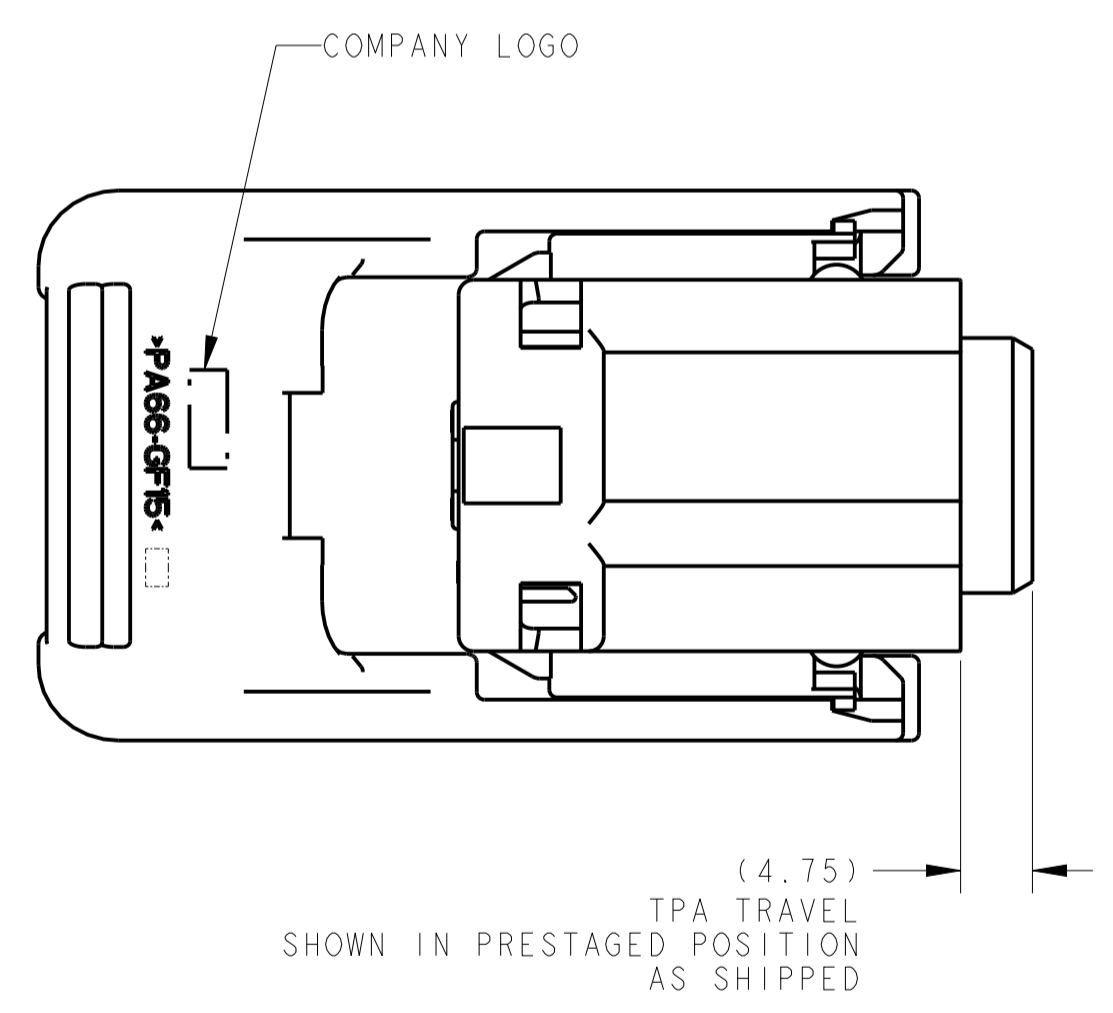
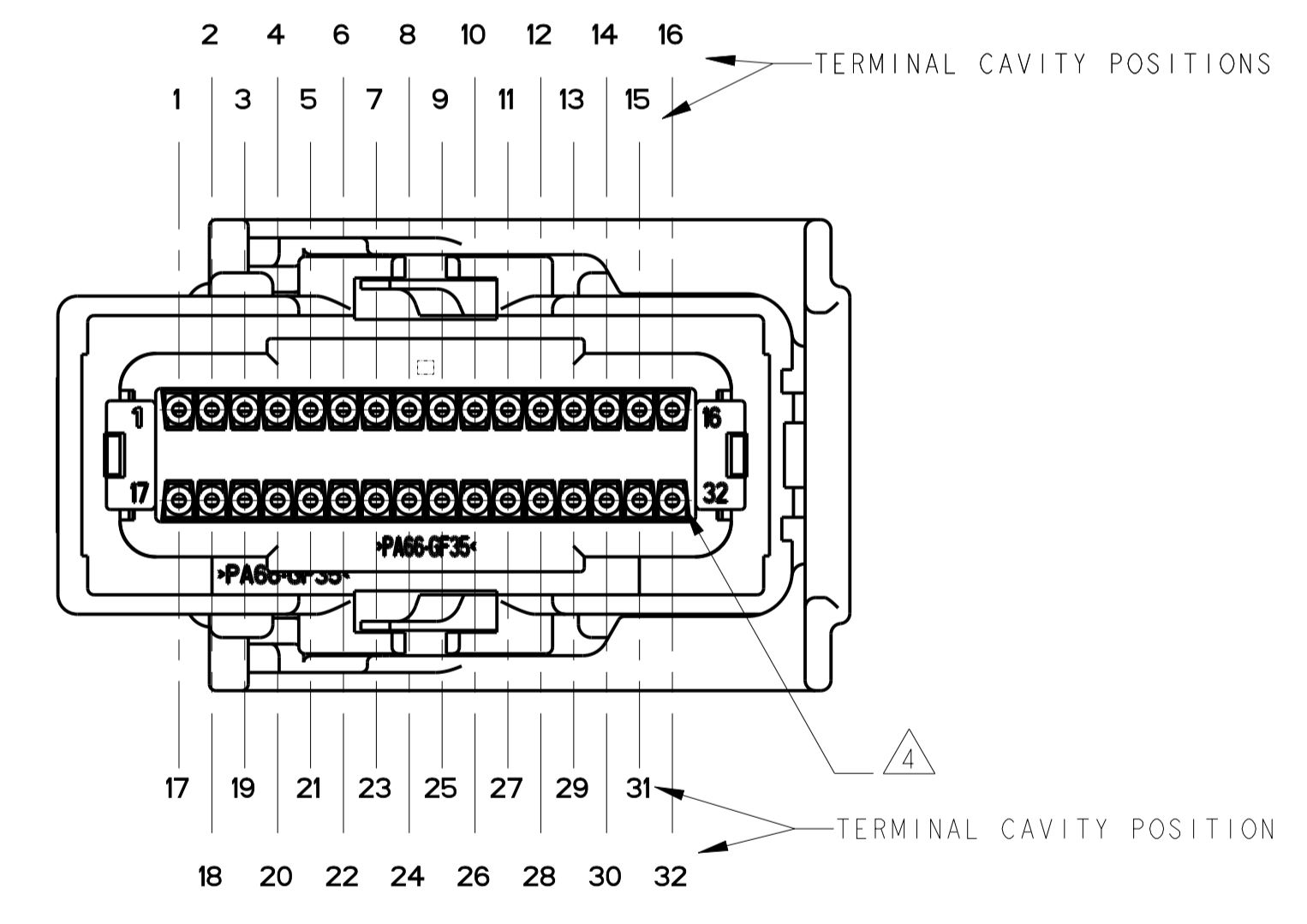
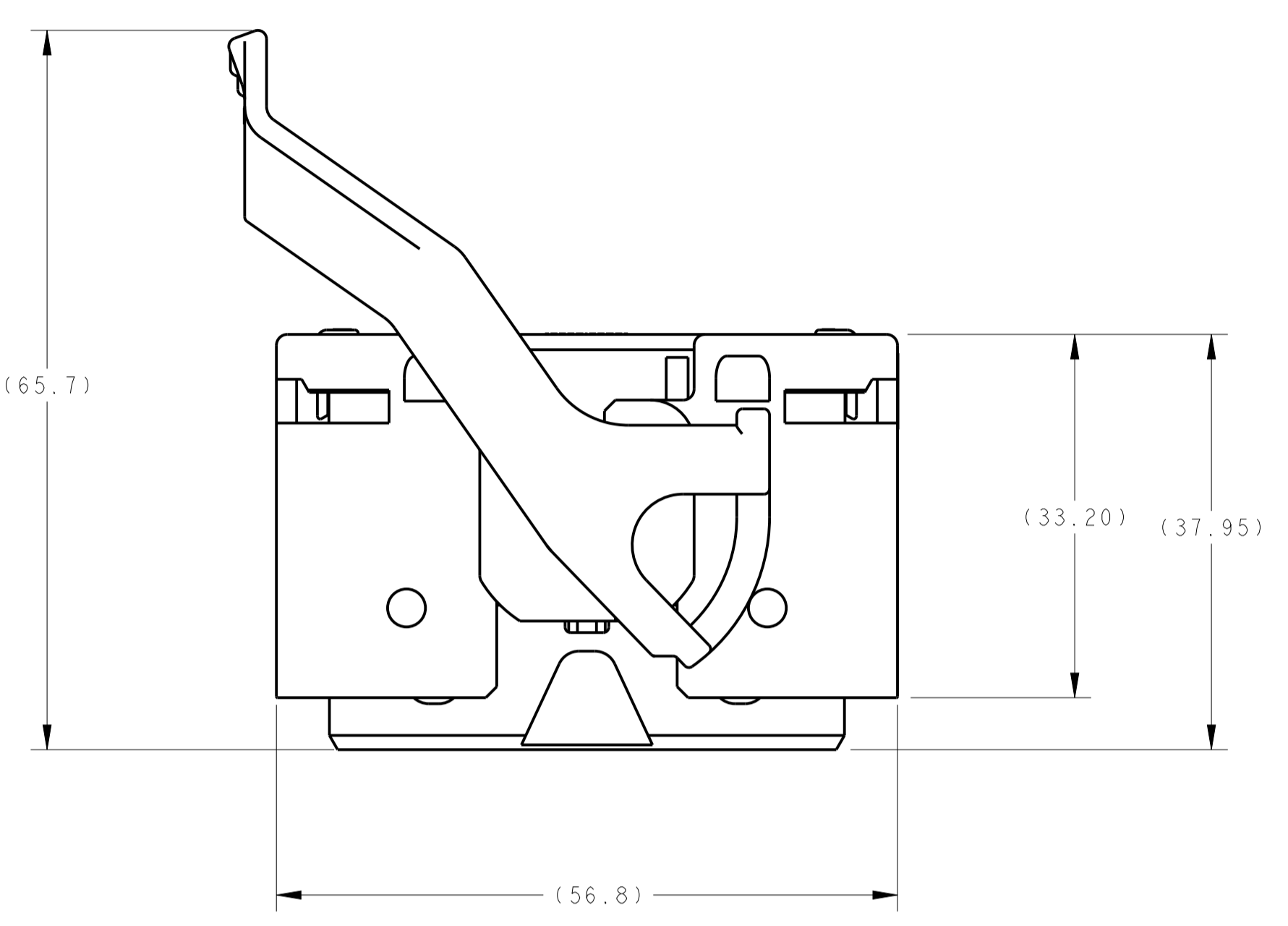

PART NUMBER: 1438640-1 SHOWN

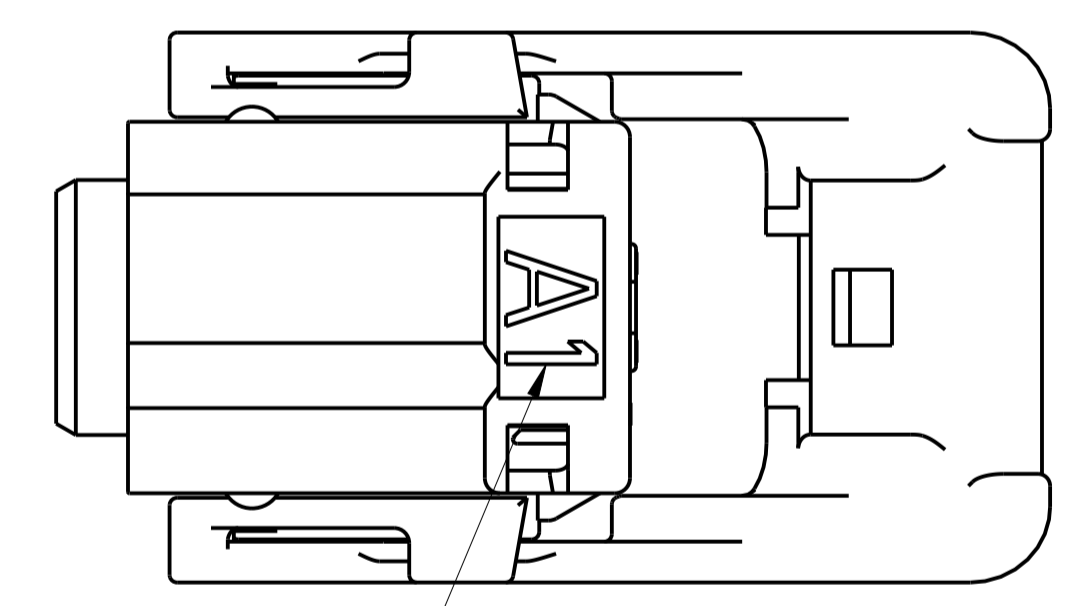

KEYING CODE LOCATED AS SHOWN
 SEE TABLE ON SHEET 1

THIS DRAWING IS A CONTROLLED DOCUMENT.		DWN D. J. HARDY	17AUG2004		TE Connectivity
DIMENSIONS:		CHK F. KINSEY	28SEP2004		
mm	TOLERANCES UNLESS OTHERWISE SPECIFIED:	APVD F. KINSEY	28SEP2004	NAME PLUG ASSEMBLY, SEALED, 32 POSITION, SHUNTED, 0.64mm	
	0 PLC ±	PRODUCT SPEC		SIZE CAGE CODE DRAWING NO	
	1 PLC ±	108-2217		A100779C=1438640	
	2 PLC ±	APPLICATION SPEC		RESTRICTED TO	
	3 PLC ±	408-10078		SCALE 2:1 SHEET 2 OF 5	
	4 PLC ±	WEIGHT		REV B 17	
	ANGLES ±	CUSTOMER DRAWING			
MATERIAL	FINISH				

LOC		DIST		REVISIONS			
1	N	00		DESCRIPTION	DATE	OWN	APVD
				SEE SHEET 1			

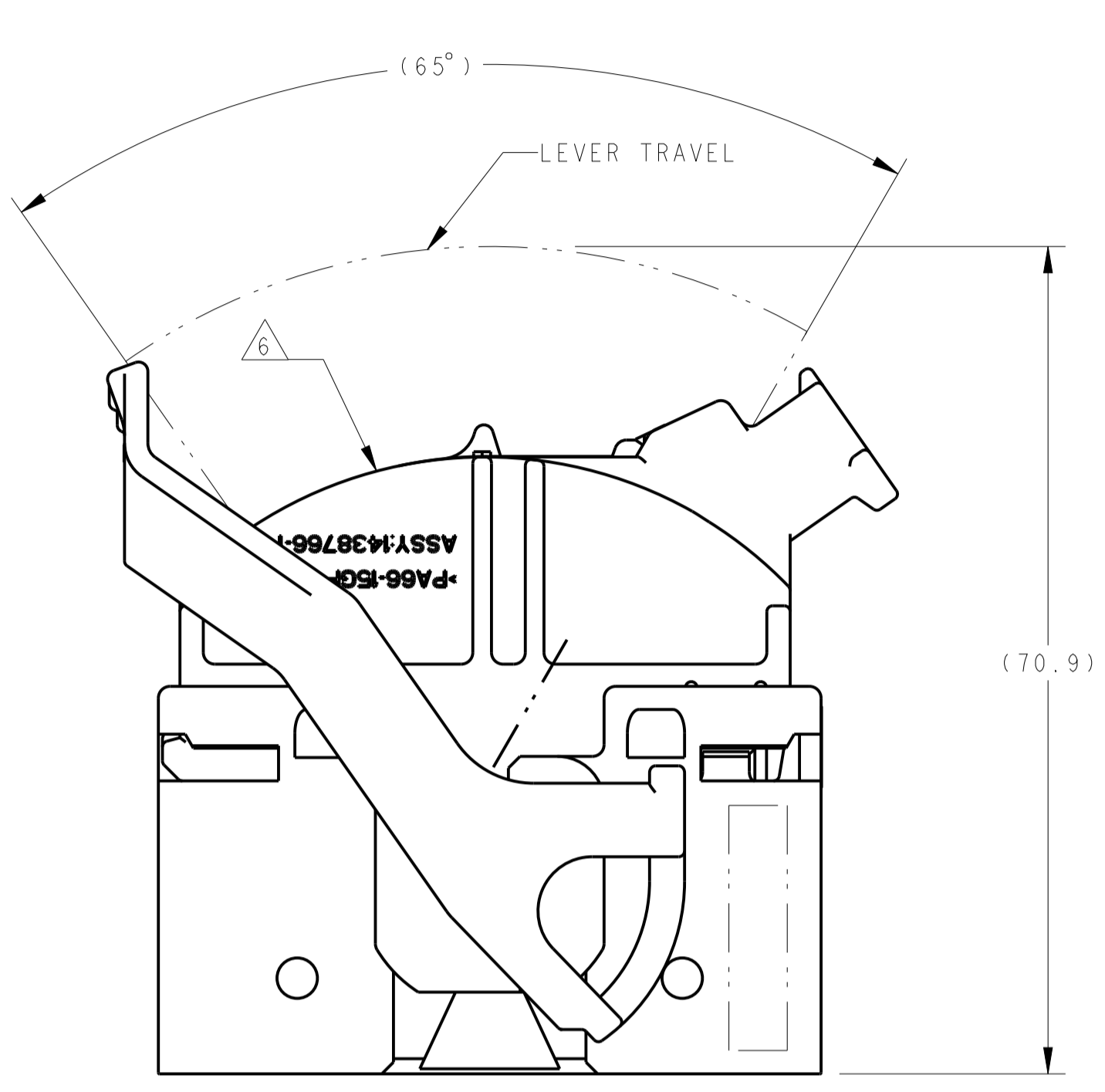

FIGURE 1
SHOWING WIRE DRESS
AND LEVER IN
STANDARD ORIENTATION
WITH KEYING CODE A1

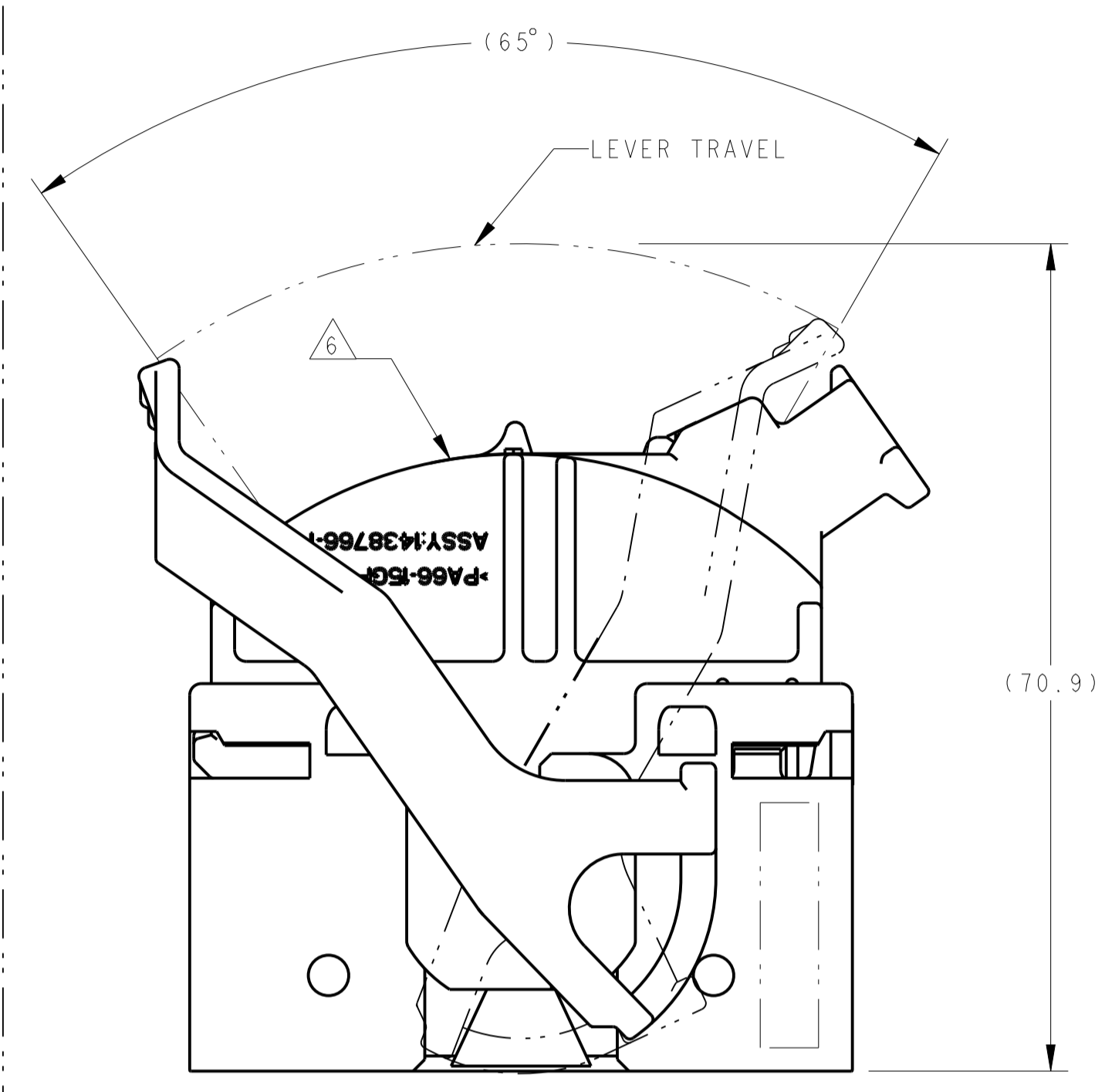

FIGURE 2
SHOWING WIRE DRESS
AND LEVER IN
STANDARD ORIENTATION
WITH KEYING CODE B1

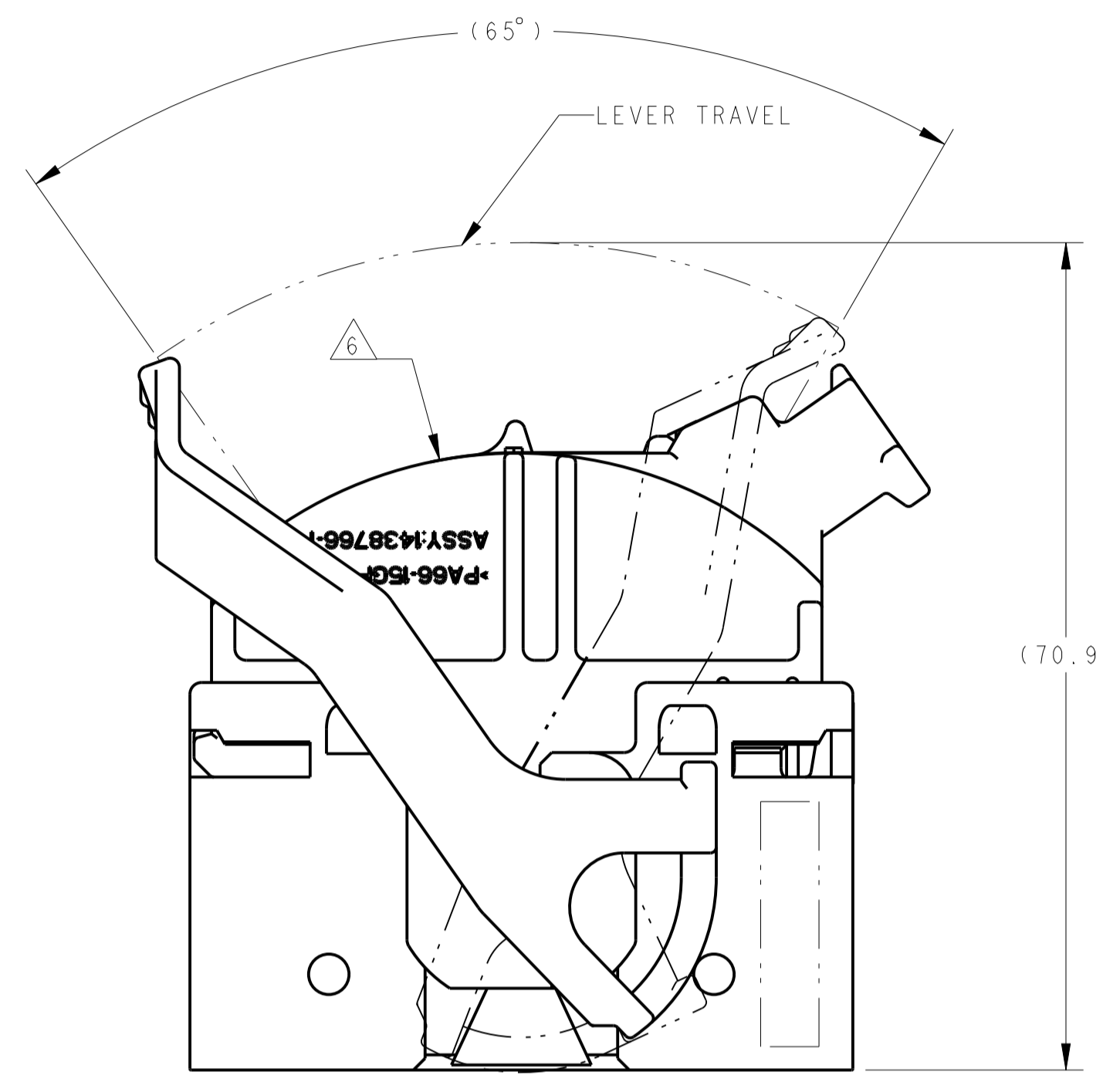

FIGURE 3
SHOWING WIRE DRESS
AND LEVER IN
STANDARD ORIENTATION
WITH KEYING CODE B2

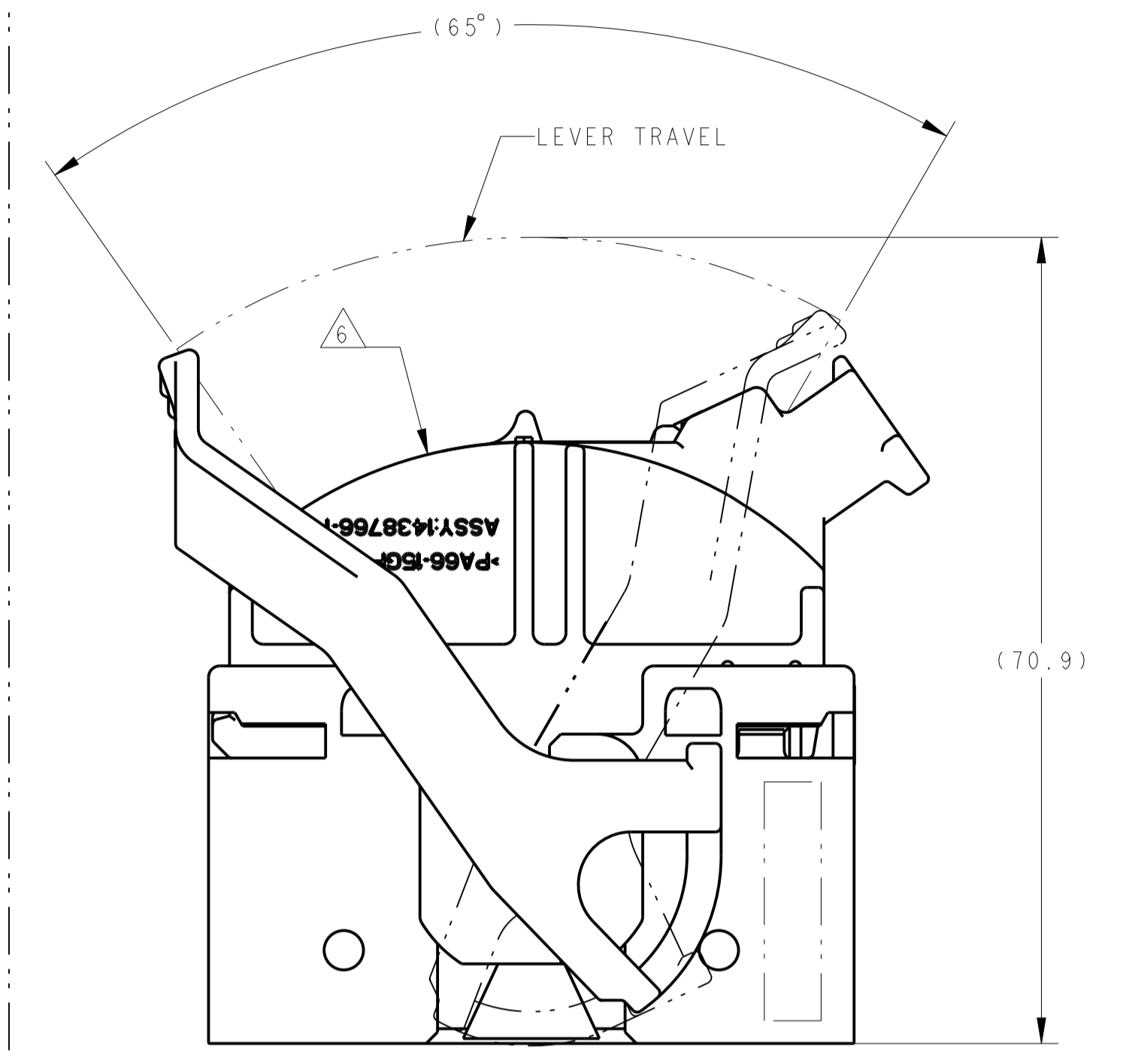
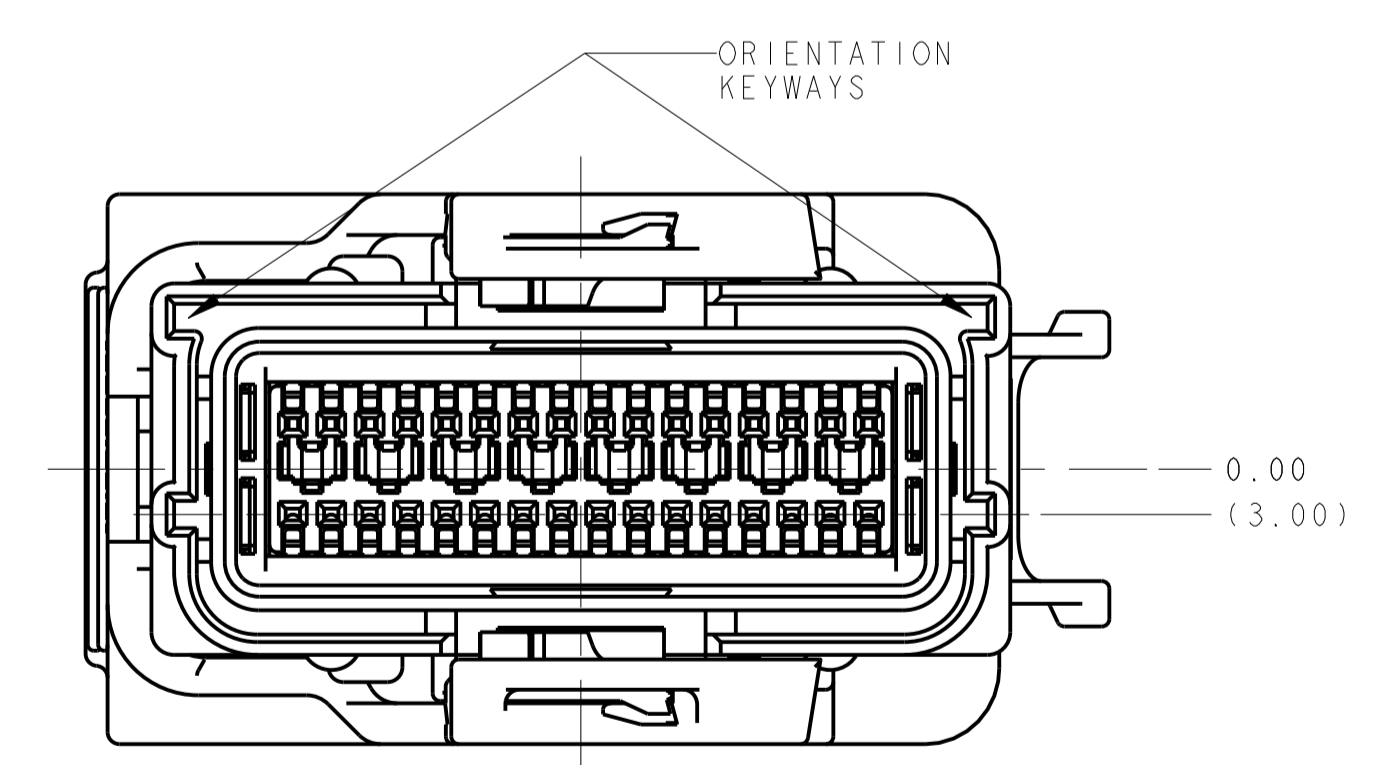
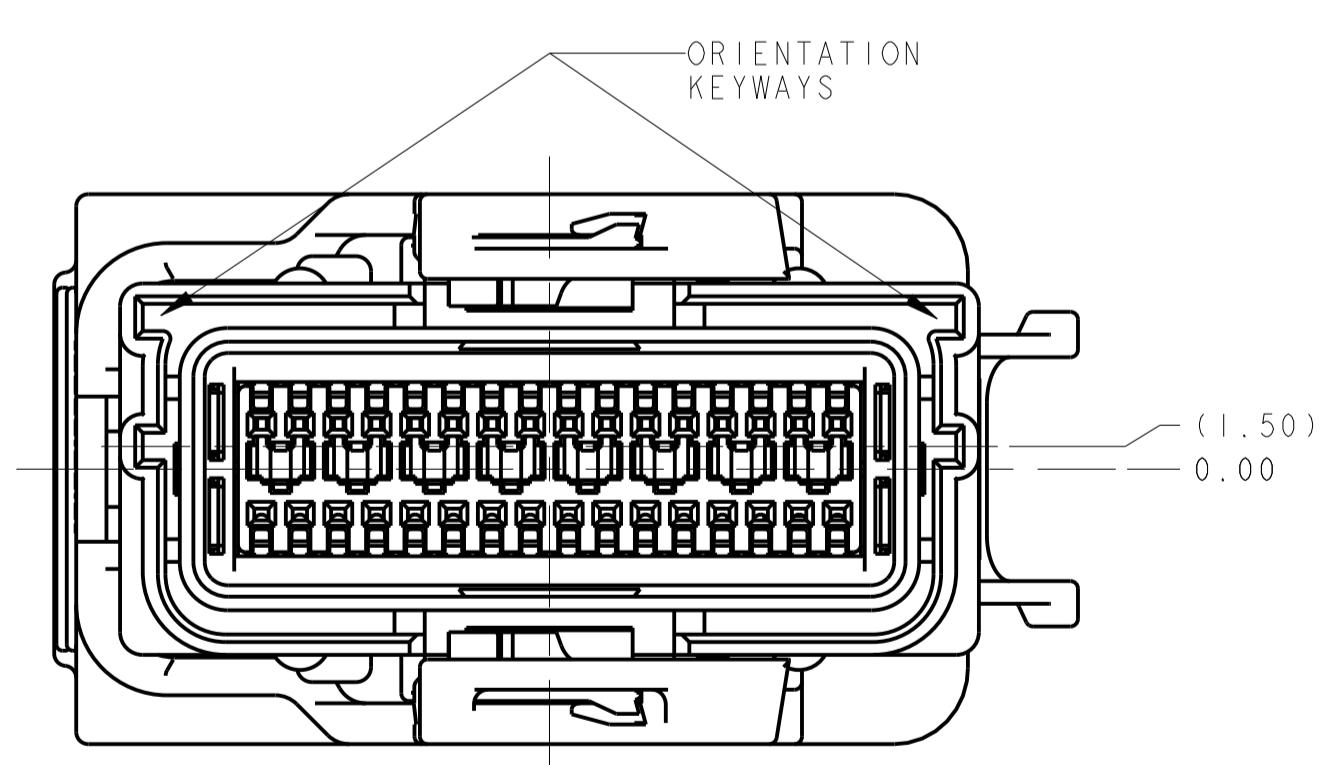
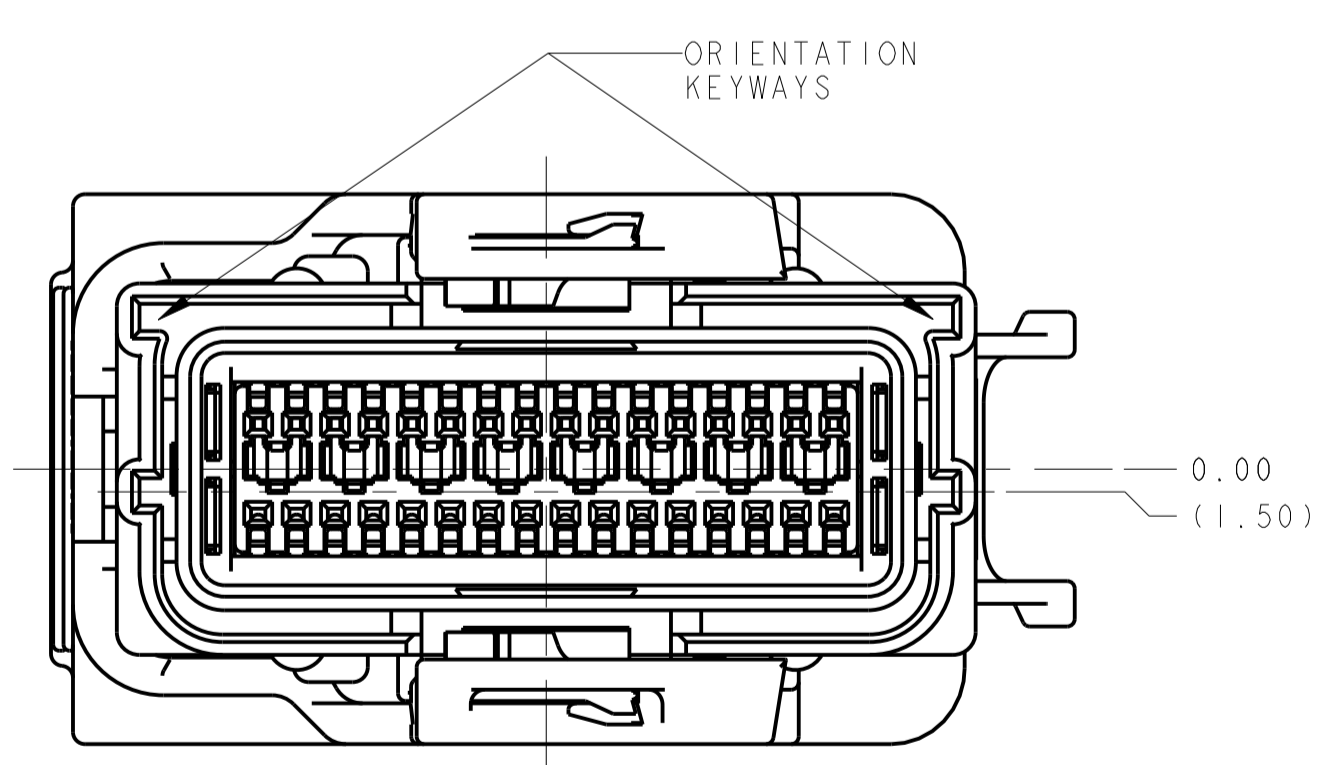
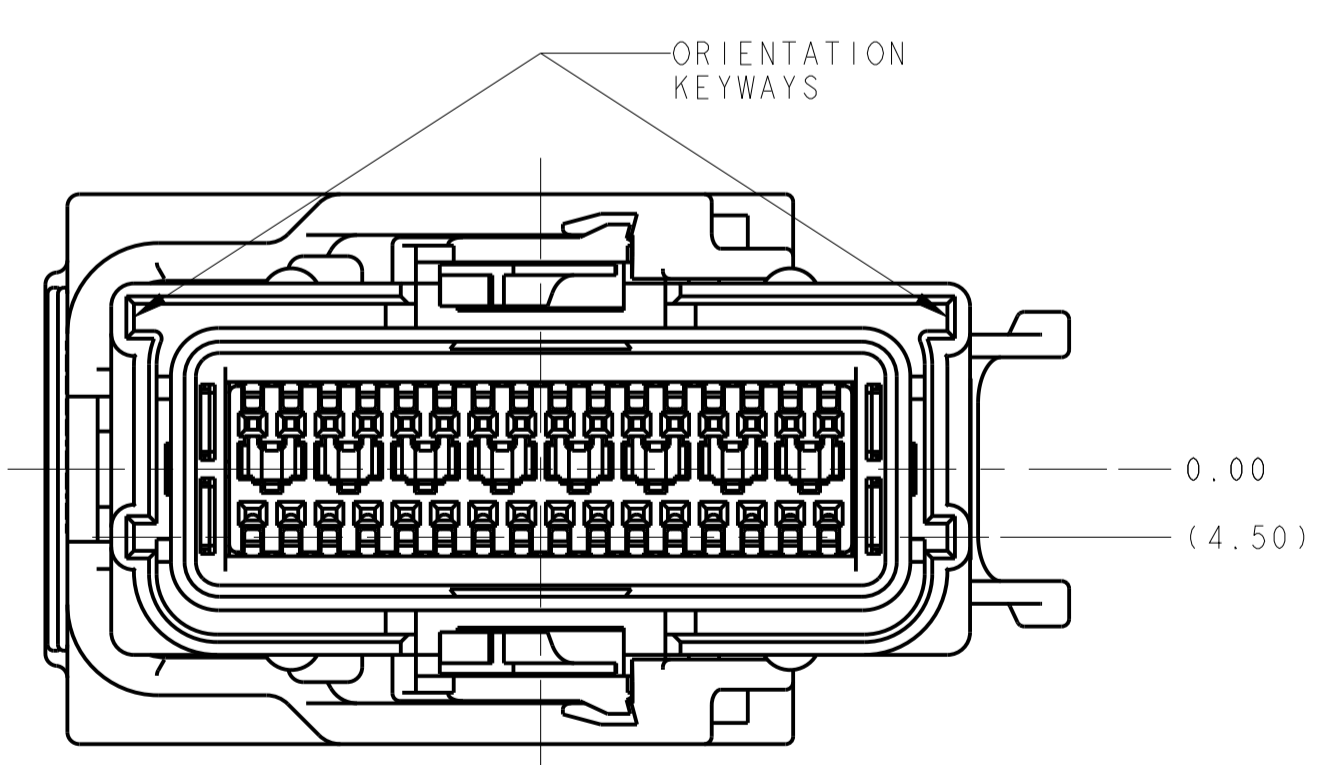

FIGURE 4
SHOWING WIRE DRESS
AND LEVER IN
STANDARD ORIENTATION
WITH KEYING CODE A2



THIS DRAWING IS A CONTROLLED DOCUMENT.		OWN: D. J. HARDY 11AUG2004	TE Connectivity
DIMENSIONS: mm		CHK: F. KINSEY 28SEP2004	
TOLERANCES UNLESS OTHERWISE SPECIFIED:		APVD: F. KINSEY 28SEP2004	NAME: PLUG ASSEMBLY, SEALED, 32 POSITION, SHUNTED, 0.64mm
0 PLC ± 1 PLC ± 2 PLC ± 3 PLC ± 4 PLC ± ANGLES ±		PRODUCT SPEC: 108-2217 APPLICATION SPEC: 408-10078	
MATERIAL: -		WEIGHT: -	SIZE: A1 CAGE CODE: 1438640 DRAWING NO: 100779
FINISH: -		CUSTOMER DRAWING	RESTRICTED TO: - SCALE: 2:1 SHEET 3 OF 5 REV: 17

LOC		DIST		REVISIONS			
1	N	00		DESCRIPTION	DATE	DWN	APVD
				SEE SHEET 1			

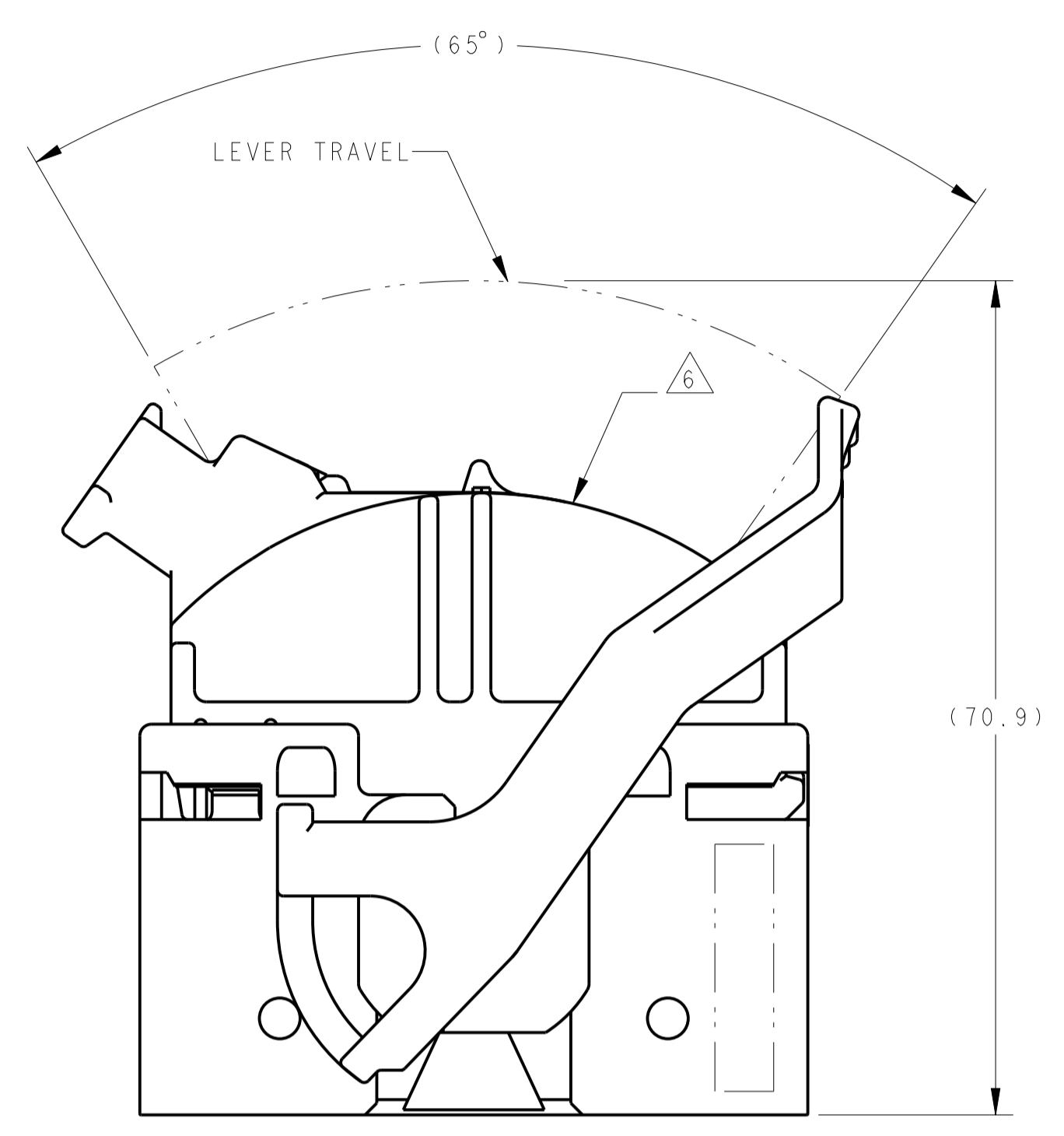

FIGURE 5
SHOWING WIRE DRESS
AND LEVER IN
ALTERNATE ORIENTATION
WITH KEYING CODE A1

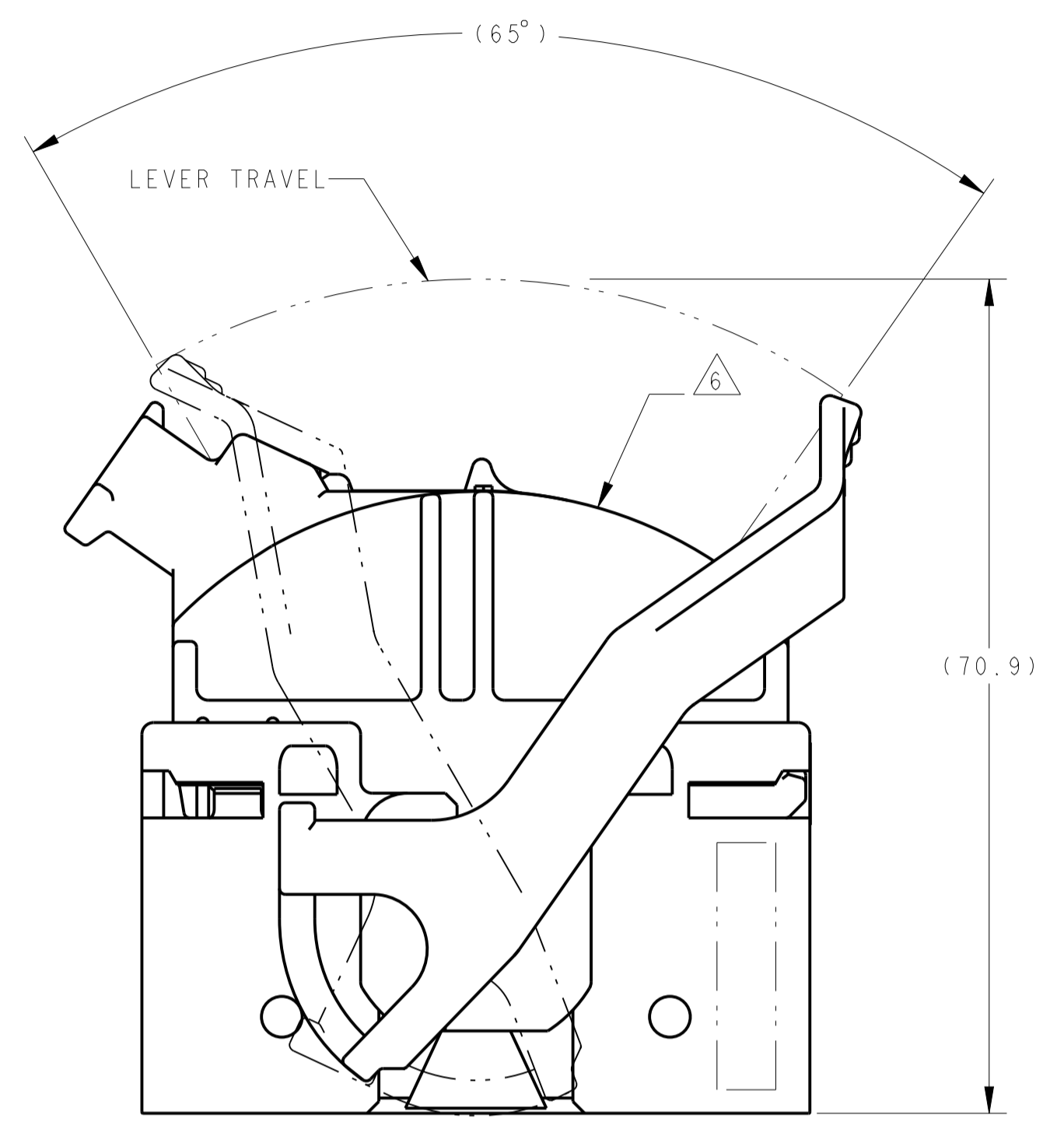

FIGURE 6
SHOWING WIRE DRESS
AND LEVER IN
ALTERNATE ORIENTATION
WITH KEYING CODE B1

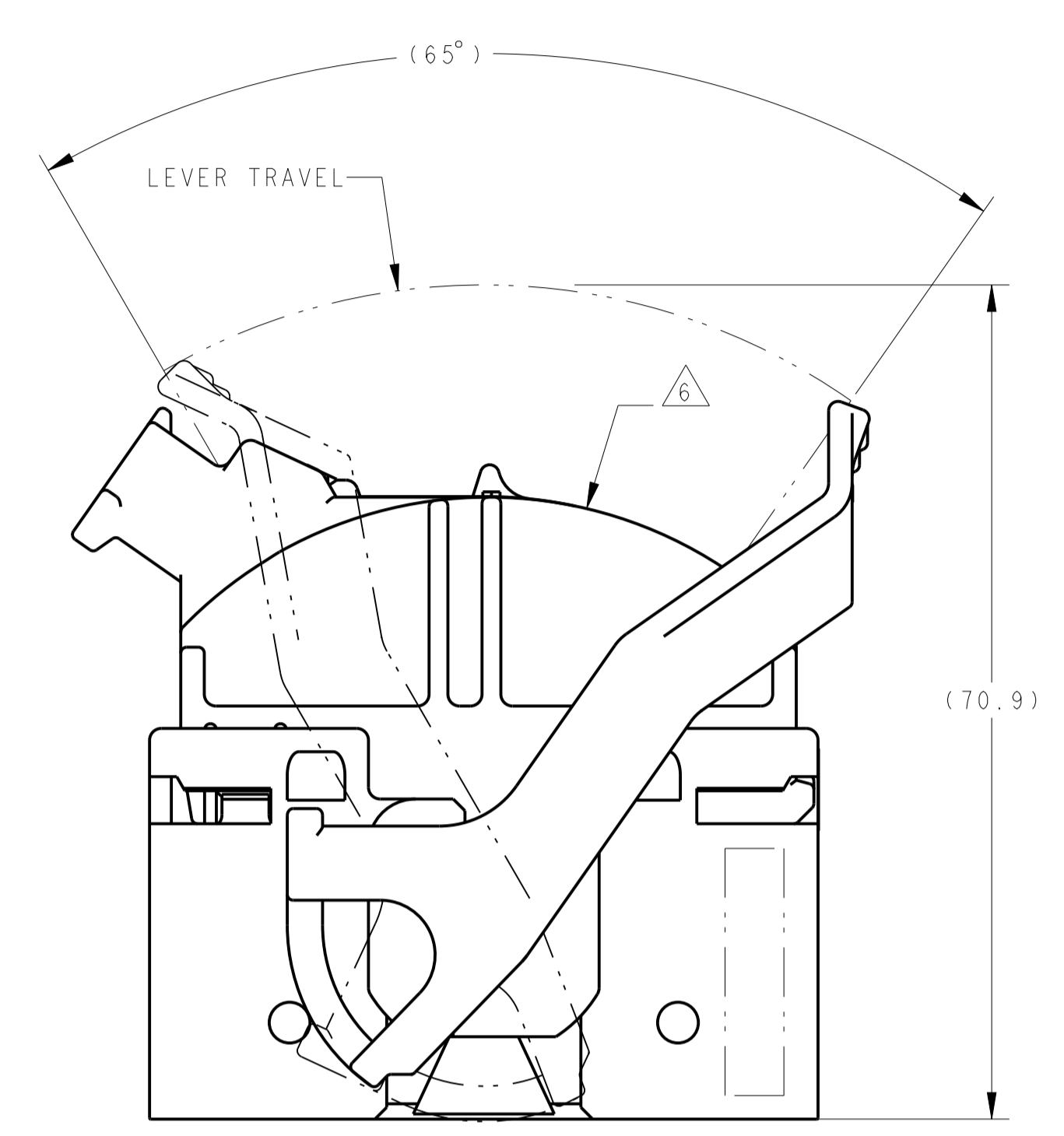

FIGURE 7
SHOWING WIRE DRESS
AND LEVER IN
ALTERNATE ORIENTATION
WITH KEYING CODE B2

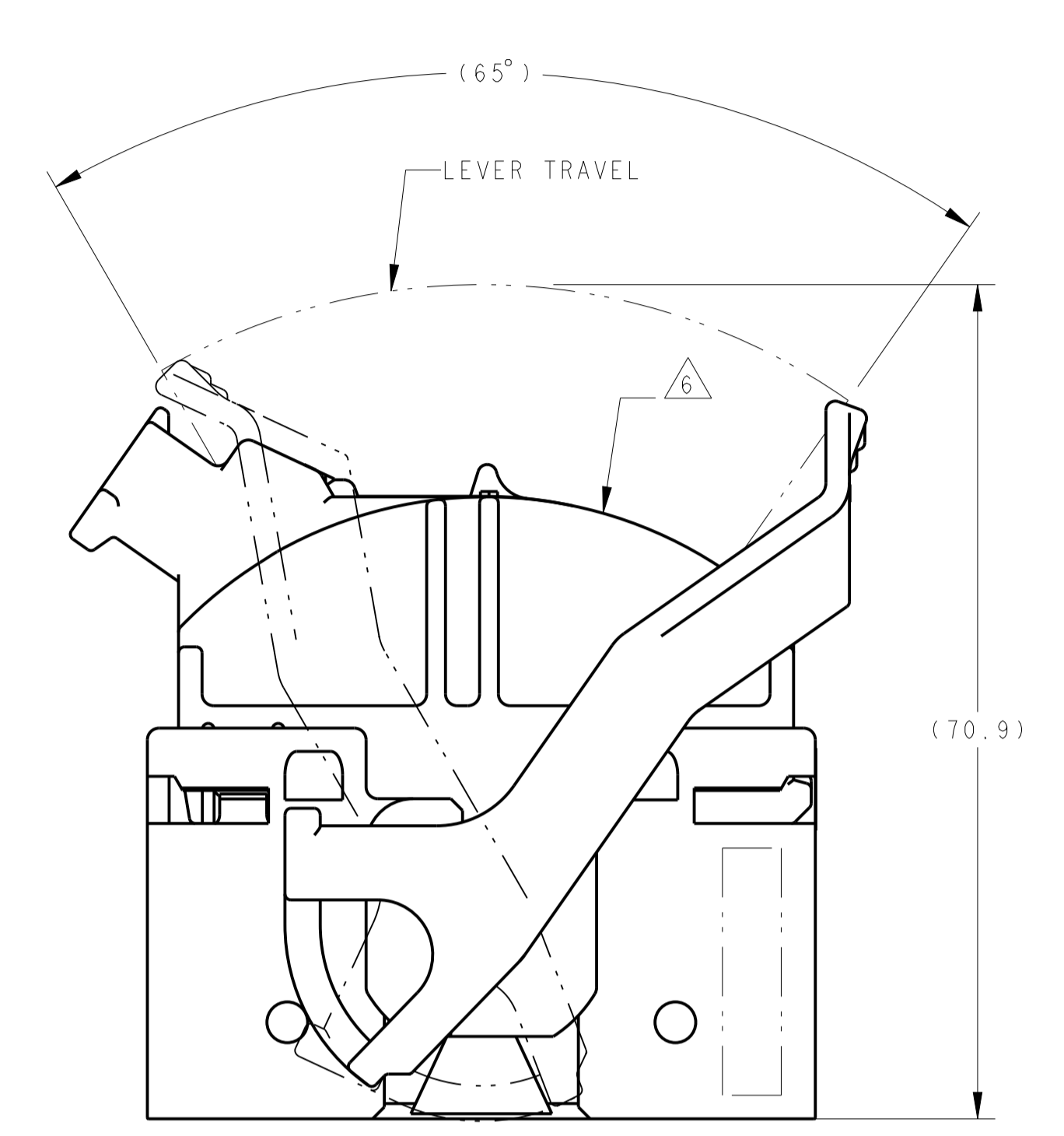
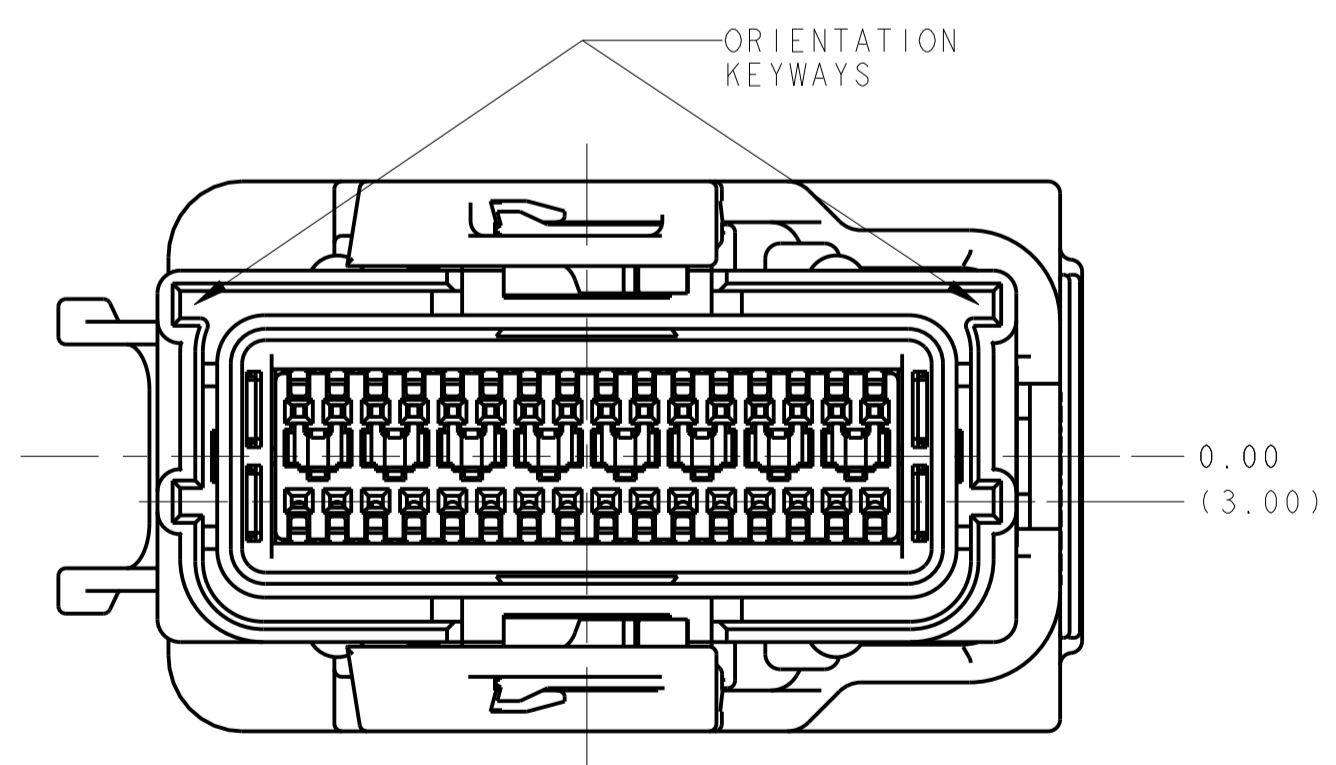
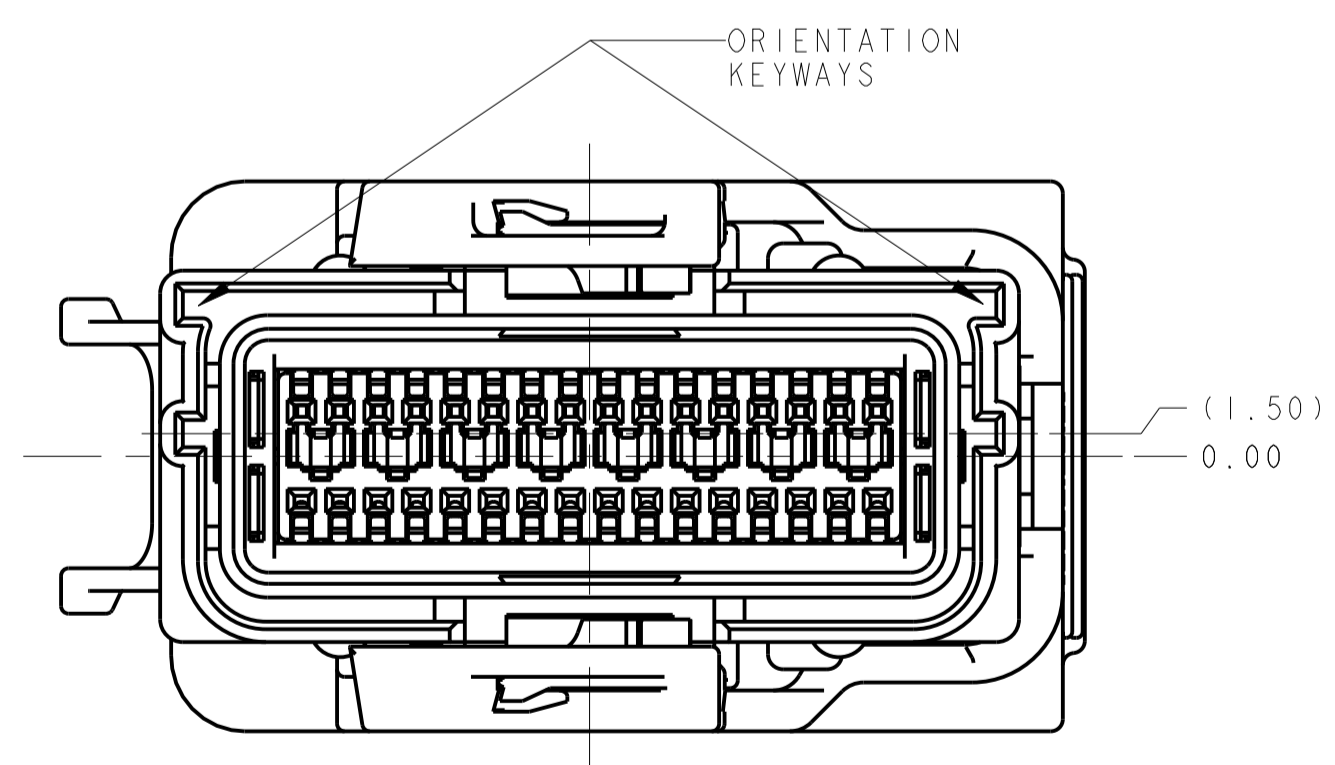
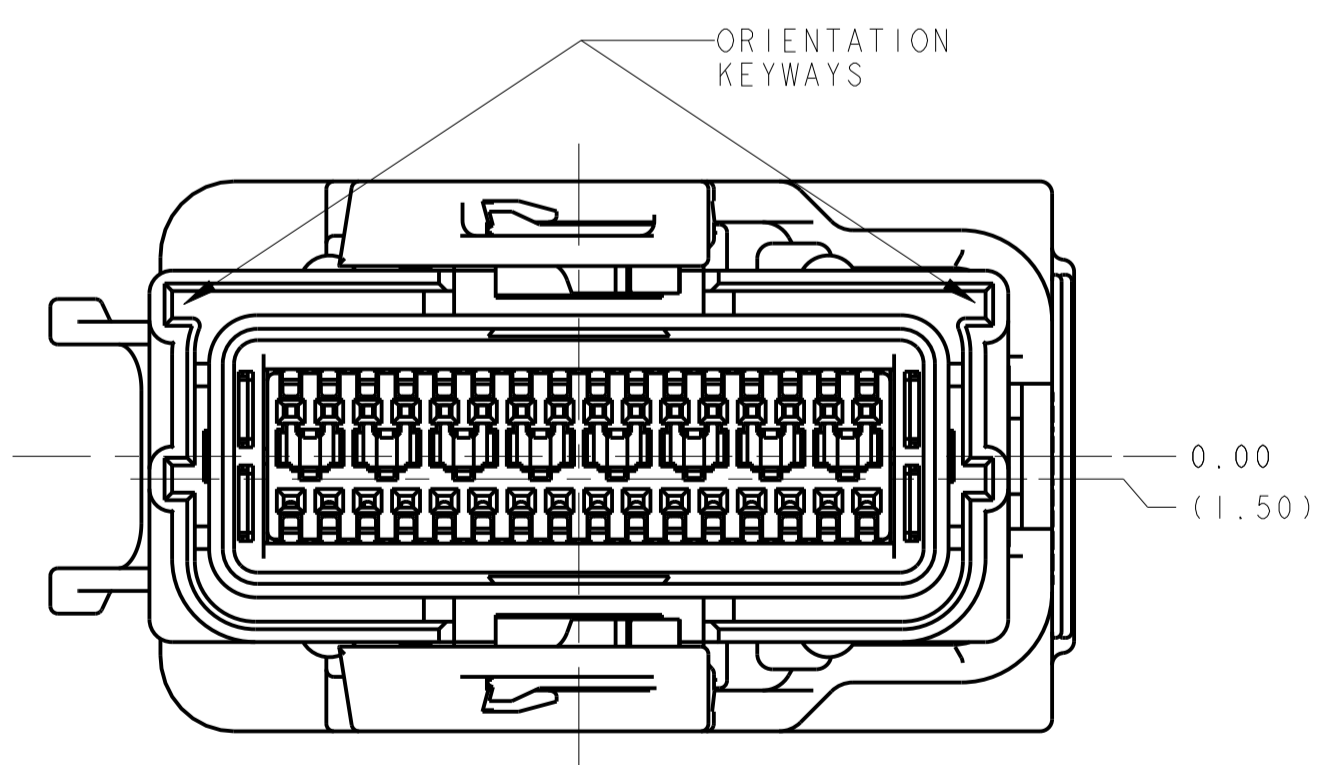
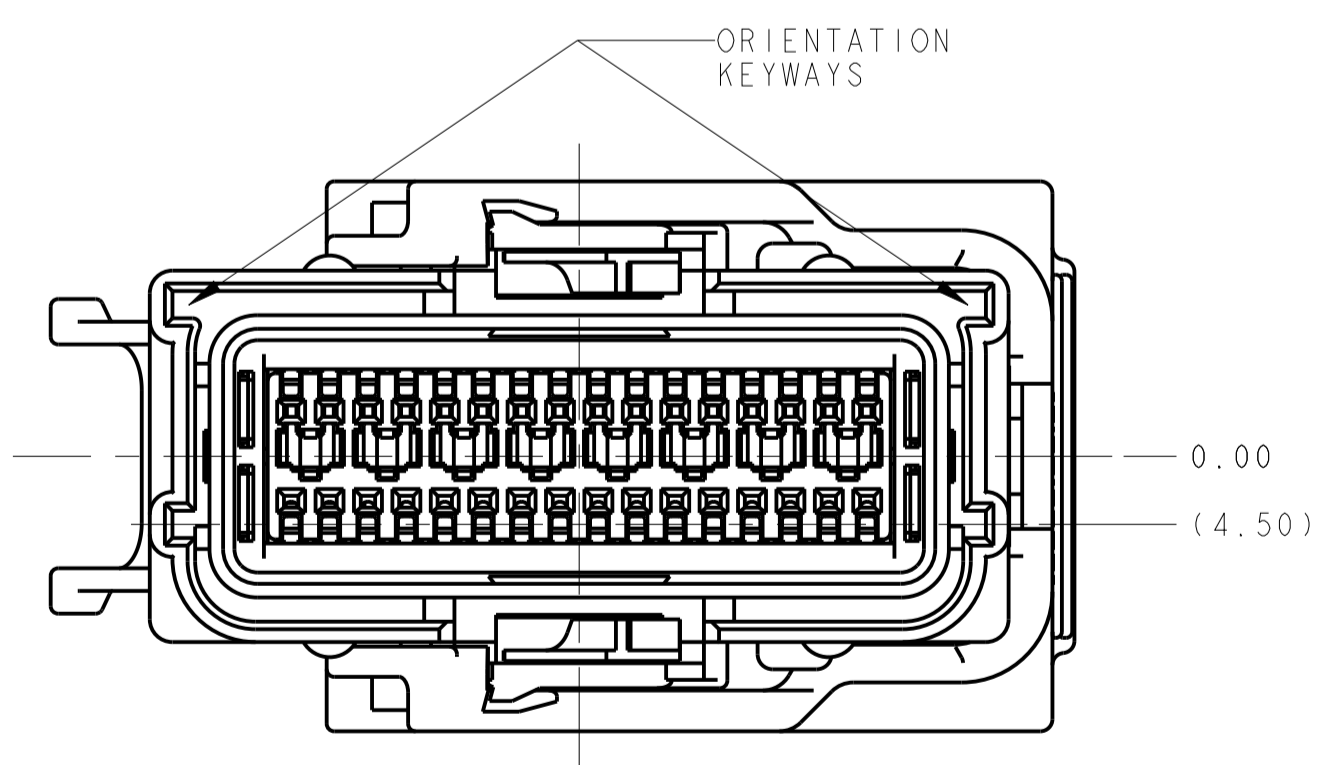

FIGURE 8
SHOWING WIRE DRESS
AND LEVER IN
ALTERNATE ORIENTATION
WITH KEYING CODE A2



THIS DRAWING IS A CONTROLLED DOCUMENT.

DIMENSIONS:	TOLERANCES UNLESS OTHERWISE SPECIFIED:	DWN: D. J. HARDY 11AUG2004	CHK: F. KINSEY 28SEP2004	TE Connectivity
mm	0 PLC ±	APVD: F. KINSEY 28SEP2004	NAME: PLUG ASSEMBLY, SEALED, 32 POSITION, SHUNTED, 0.64mm	
	1 PLC ±	PRODUCT SPEC: 108-2217	SIZE: CAGE CODE DRAWING NO: A100779C=1438640	RESTRICTED TO:
	2 PLC ±	APPLICATION SPEC: 408-10078	SCALE: 2:1	SHEET 4 OF 5
MATERIAL:	FINISH:	WEIGHT:	CUSTOMER DRAWING	REV: 17

LOC		DIST		REVISIONS			
				REV	DATE	BY	APPV
1	N	00		-			
				-	SEE SHEET 1		

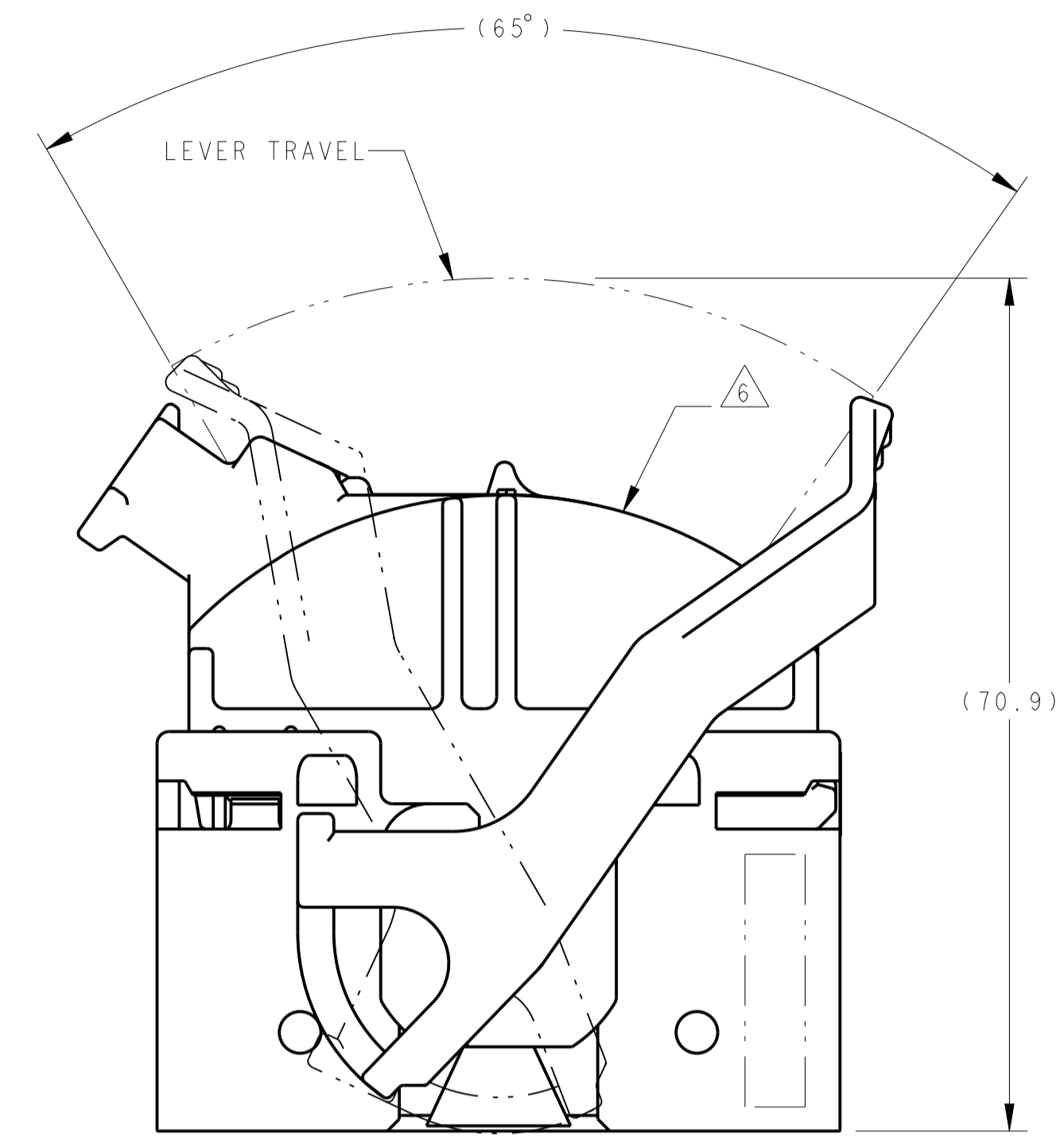

**FIGURE 9
SHOWING WIRE DRESS
AND LEVER IN
ALTERNATE ORIENTATION
WITH KEYING CODE B3**

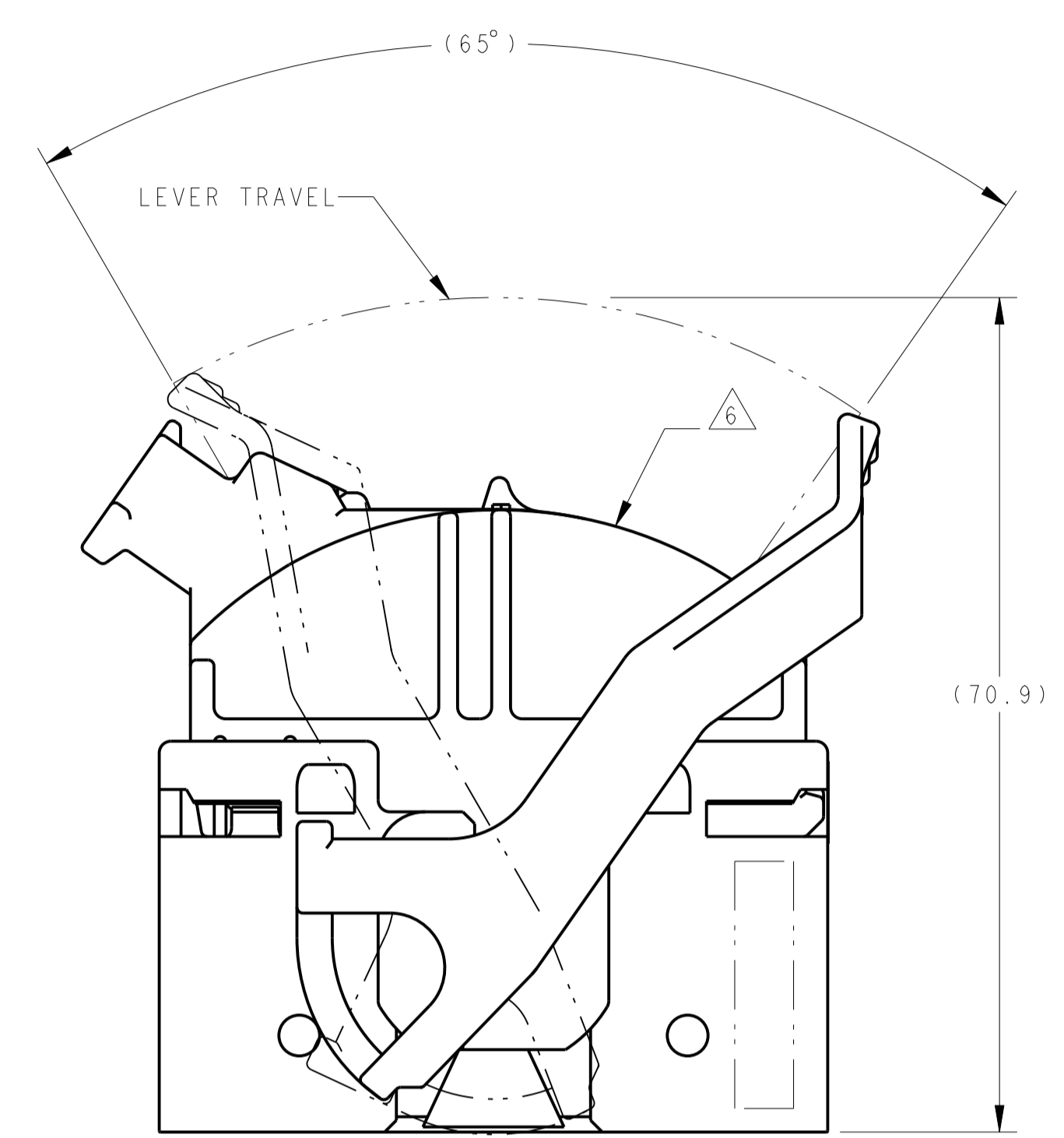

**FIGURE 10
SHOWING WIRE DRESS
AND LEVER IN
ALTERNATE ORIENTATION
WITH KEYING CODE A3**

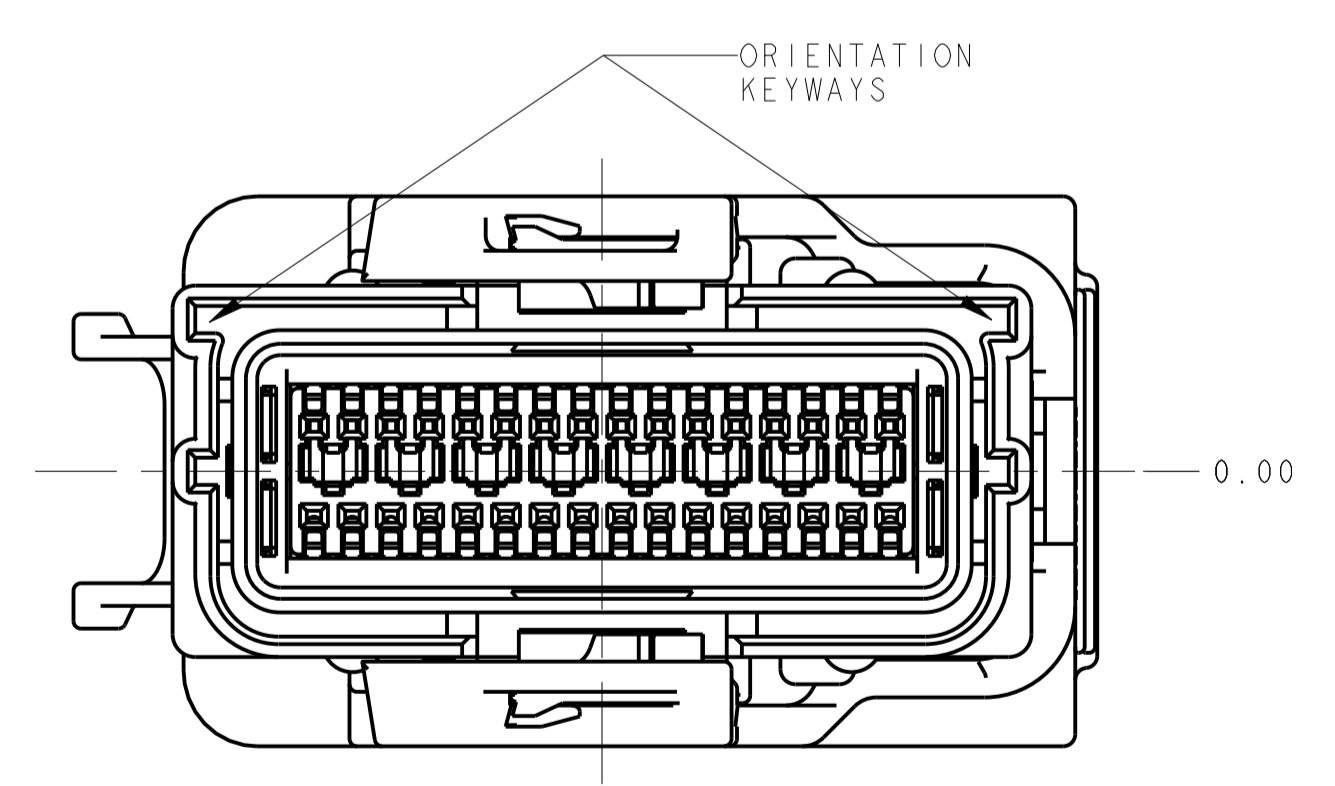
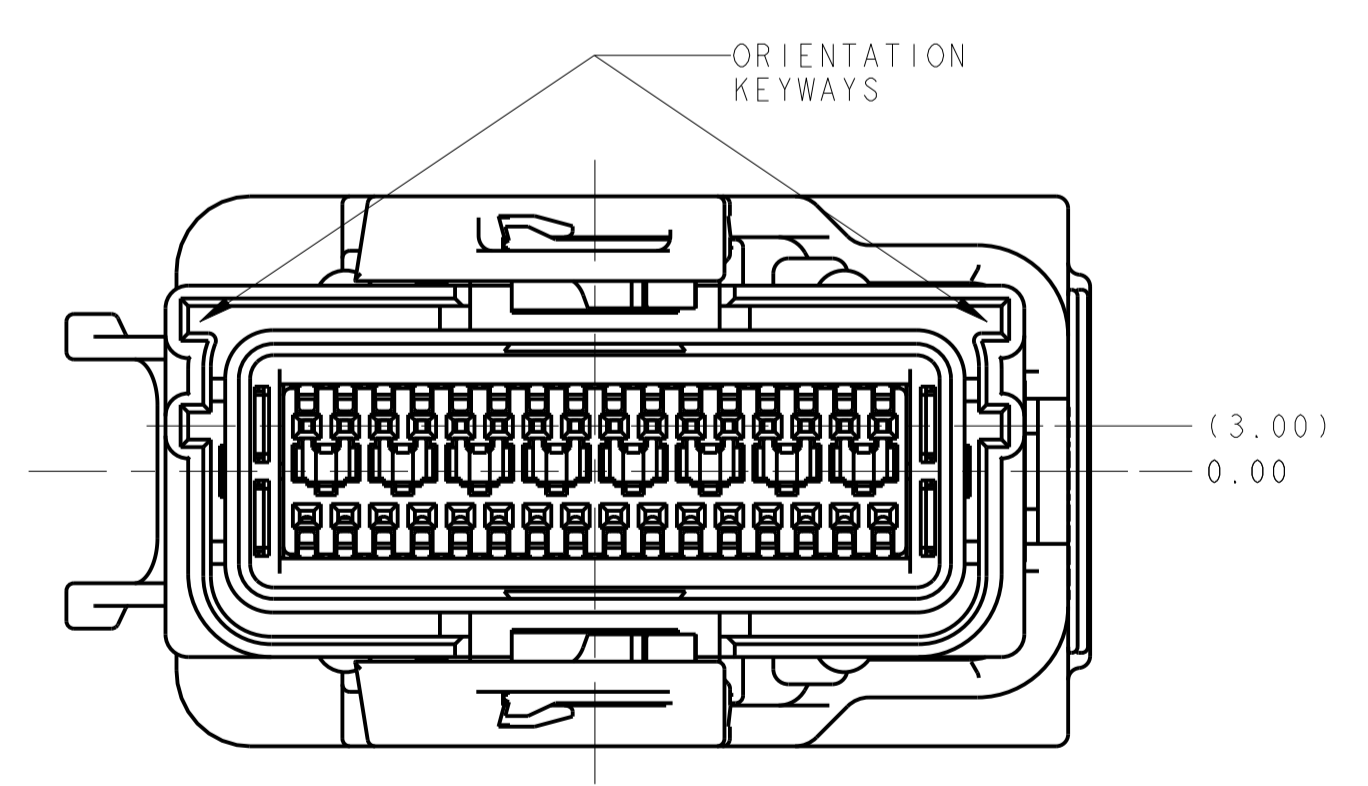

THIS DRAWING IS A CONTROLLED DOCUMENT.		OWN D. J. HARDY 17AUG2004															
DIMENSIONS:		CHK F. KINSEY 28SEP2004															
mm	TOLERANCES UNLESS OTHERWISE SPECIFIED:	APVD F. KINSEY 28SEP2004	NAME PLUG ASSEMBLY, SEALED, 32 POSITION, SHUNTED, 0.64mm														
<table border="1"> <tr><td>0 PLC</td><td>±</td></tr> <tr><td>1 PLC</td><td>±</td></tr> <tr><td>2 PLC</td><td>±</td></tr> <tr><td>3 PLC</td><td>±</td></tr> <tr><td>4 PLC</td><td>±</td></tr> </table>	0 PLC	±	1 PLC	±	2 PLC	±	3 PLC	±	4 PLC	±	<table border="1"> <tr><td>PRODUCT SPEC</td><td>108-2217</td></tr> <tr><td>APPLICATION SPEC</td><td>408-10078</td></tr> </table>	PRODUCT SPEC	108-2217	APPLICATION SPEC	408-10078	SIZE A1	RESTRICTED TO
0 PLC	±																
1 PLC	±																
2 PLC	±																
3 PLC	±																
4 PLC	±																
PRODUCT SPEC	108-2217																
APPLICATION SPEC	408-10078																
MATERIAL	FINISH	WEIGHT	SCALE 2:1 SHEET 5 OF 5														
CUSTOMER DRAWING		REVISION 17															