

LOC	DIST	REVISIONS			
P	LTB	DESCRIPTION	DATE	DWN	APVD
0		RELEASED PER DR D05-049	18MAY2005	DLD	AJV
01		REV PER ECO-10-015982	10AUG2010	HM	DCM

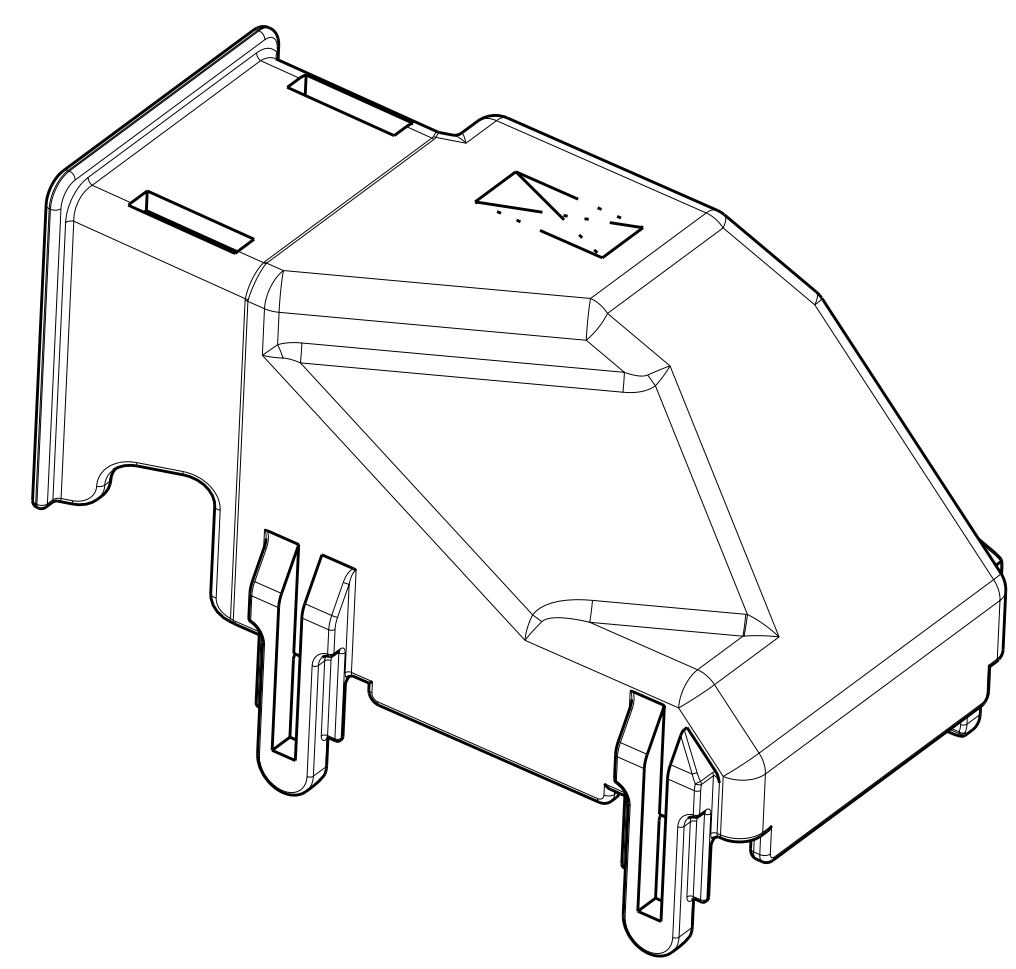

NOTE(S):

- 1 MATERIAL : PBT-GF15  
COLOR : BLACK
- 2 COMPANY LOGO LOCATED APPROXIMATELY AS SHOWN.
- 3 MOLD CAVITY I.D. & RECYCLING CODE >PBT-GF15< AS SHOWN.
- 4 25% MAXIMUM REGRIND.
- 5 PART NUMBERS APPROXIMATELY AS SHOWN AS STATED IN PART NUMBER TABLE.
- 6 DATE CODE APPROXIMATELY AS SHOWN.

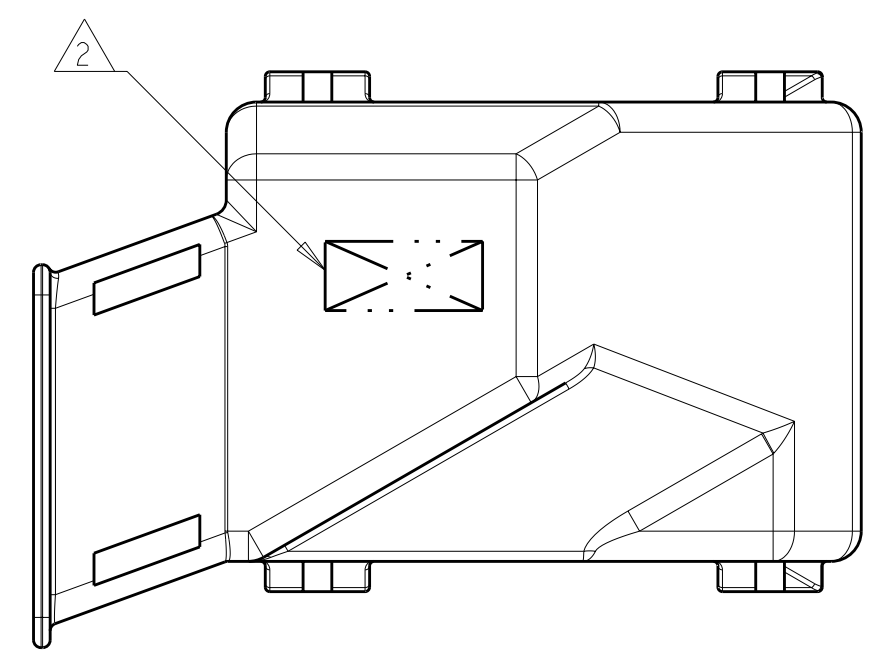
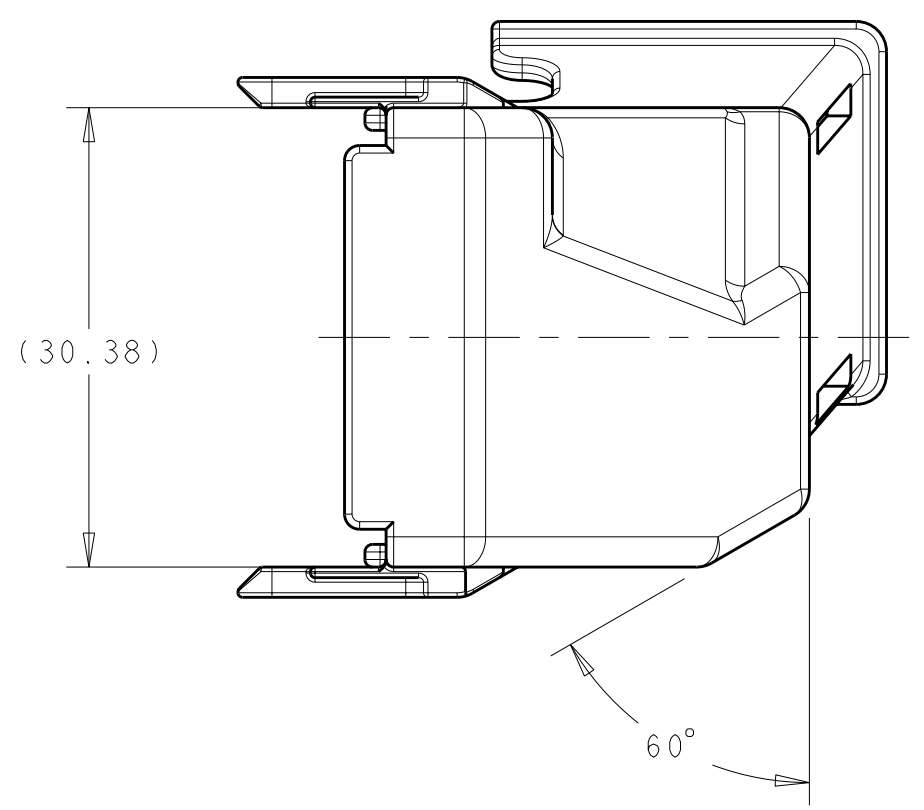
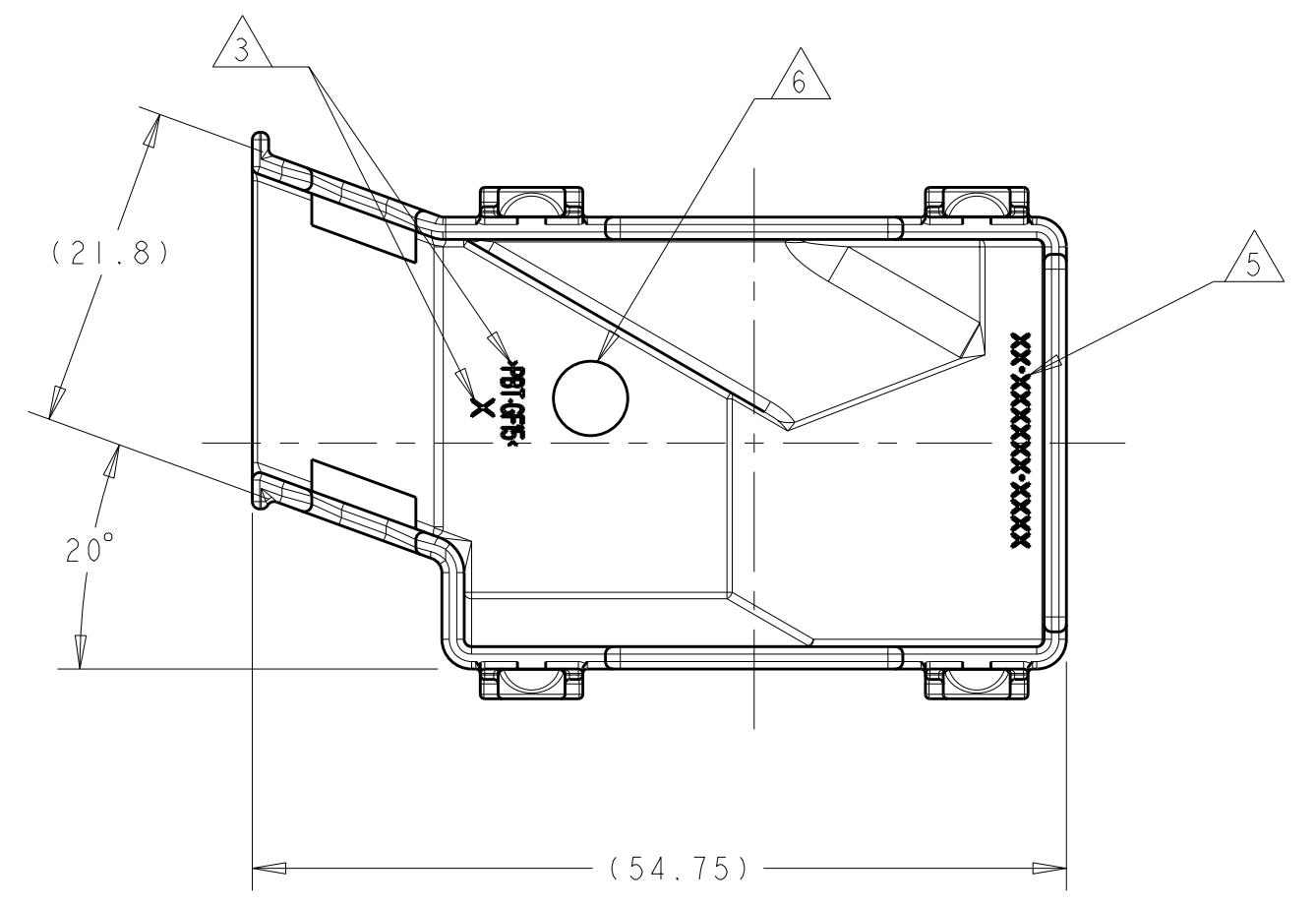
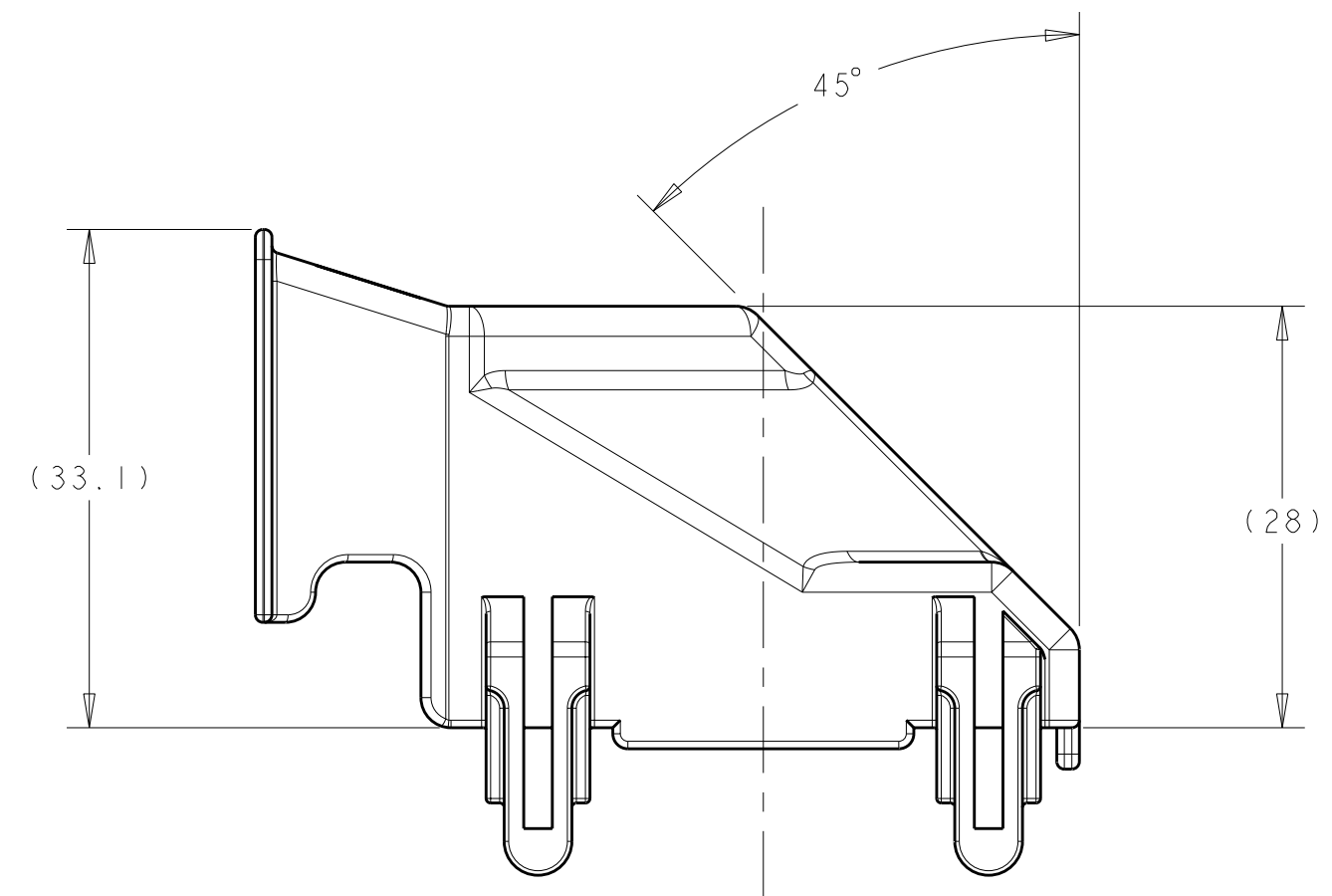

---	1438180-2
3S4T-14N003-AA	1438180-1
CUSTOMER PART NO.	PART NUMBER

<small>THIS DRAWING IS UNPUBLISHED. RELEASED FOR PUBLICATION BY TYCO ELECTRONICS CORPORATION. IT IS SUBJECT TO CHANGE WITHOUT NOTICE AND WITHOUT OBLIGATION. SHOULD BE CONTACTED FOR THE LATEST REVISION.</small>		DWN DL DRUMMOND 18MAY2005 CHK AJ VALASEK 18MAY2005 APVD AJ VALASEK 18MAY2005	Tyco Electronics Harrisburg, PA 17105-3608
DIMENSIONS: mm TOLERANCES UNLESS OTHERWISE SPECIFIED: 0 PLC ± 1 PLC ±0.3 2 PLC ±0.10 3 PLC ± 4 PLC ± ANGLES ±		PRODUCT SPEC APPLICATION SPEC WEIGHT CUSTOMER DRAWING	NAME: 50-WAY ANGLE EXIT WIRE DRESSING SIZE: A   00779   C=1438180 SCALE: 2:1 SHEET 1 OF 1 REV 01