

THIS DRAWING IS UNPUBLISHED. VERTRAULICHE UNVEROEFFENTLICHTE ZEICHNUNG. FREI FUER VEROEFFENTLICHUNG. BY AMP INCORPORATED. ALLE RECHTE VORBEHALTEN.

MATED WITH: PASSEND ZU:	LOC	DIST	REVISIONS AENDERUNGEN DESCRIPTION BESCHREIBUNG			DATE	DWN	APVD
-	AI	-	P	LTR				
PROJEKT NR.: -			A	Neue Zeichnung erstellt			01.02.00	M.P. Zitz

POS. PER ROW	L±0.5	PART-NO	
-	-	-	
2	5.08	-2	
3	7.62	-3	
4	10.16	-4	
5	12.70	-5	
6	15.24	-6	
7	17.78	-7	
8	20.32	-8	
9	22.86	-9	
10	25.40	1-	-0
11	27.94	1-	-1
12	30.48	1-	-2
13	33.02	1- 1394058	-3
14	35.56	1-	-4
15	38.10	1-	-5
16	40.64	1-	-6
17	43.18	1-	-7
18	45.72	1-	-8
19	48.26	1-	-9
20	50.80	2-	-0
21	53.34	2-	-1
22	55.88	2-	-2
23	58.42	2-	-3
24	60.96	2-	-4
25	63.50	2-	-5
26	66.04	2-	-6
27	68.58	2-	-7
28	71.12	2-	-8
29	73.66	2-	-9
30	76.20	3-	-0
31	78.74	3-	-1
32	81.28	3-	-2
33	83.82	3-	-3
34	86.36	3-	-4
35	88.90	3-	-5
36	91.44	3-	-6
37	93.98	3-	-7
38	96.52	3-	-8
39	99.06	3-	-9
40	101.60	4-	-0
41	104.14	4-	-1
42	106.68	4-	-2
43	109.22	4-	-3
44	111.76	4-	-4
45	114.30	4-	-5
46	116.84	4-	-6
47	119.38	4-	-7
48	121.92	4-	-8
49	124.46	4-	-9
50	127.00	5-	-0

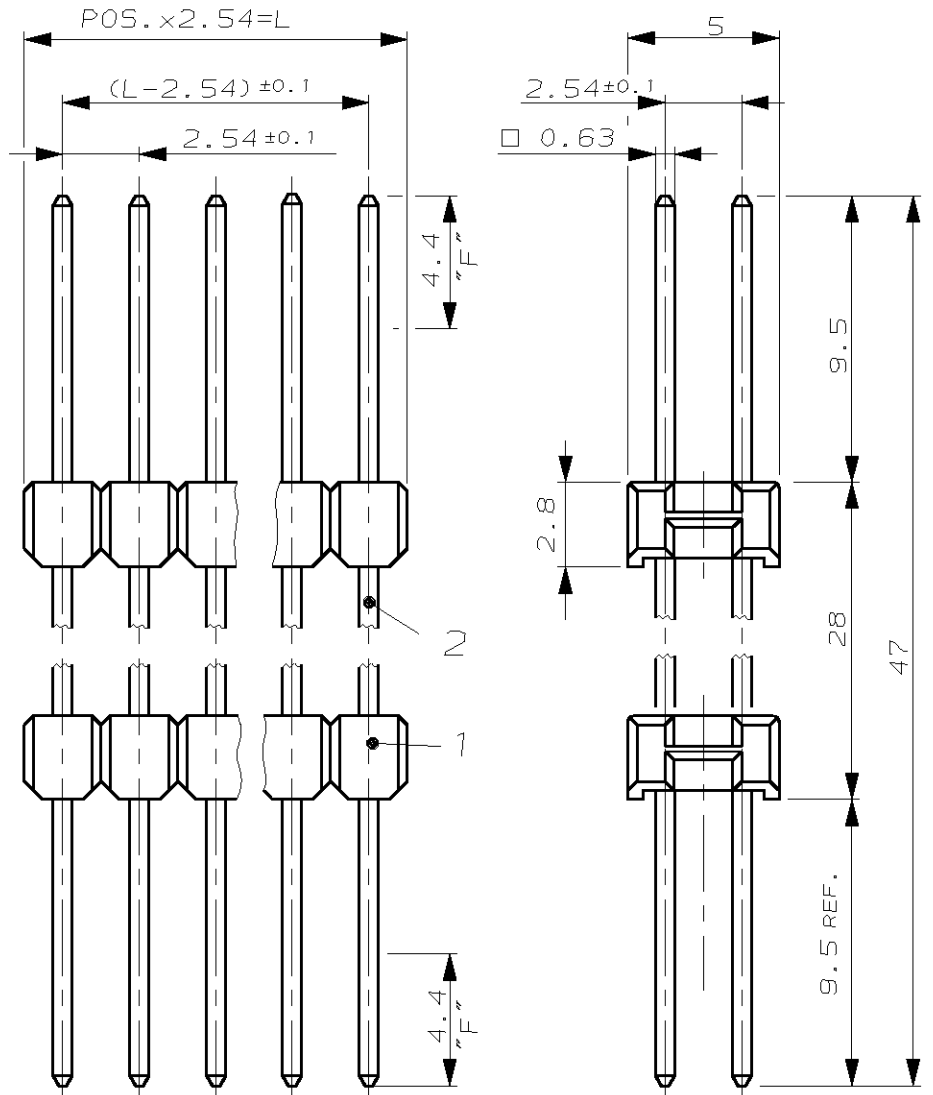

⚠ SEL. GOLD PLATED BY AREA "F"

-	-	-	-	CuSn	⚠	Stiftkontakt	-
-	-	-	-	PBT	grün	Gehäuse	-
CUSTOMER PART NO	AMP PART NO	REV.	PCS.	MATERIAL	SURFACE COLOR	DESCRIPTION	

DIMENSIONS: DIMENSIONEN: mm	DWN A. Zitz	08-NOV-99	MATERIAL	-	FINISH OBERFLAECHE/FARBE	-
TOLERANCES UNLESS OTHERWISE SPECIFIED; ALLGEMEINTOLERANZEN	CHK	-	AMP Deutschland GmbH D - 63225 Langen			
p. 150 8015 p. 150 2768 - mH - E p. DIN 16901 - 140	APVD	-				
0 PLC ± 1 PLC ±0.2mm 2 PLC ± 3 PLC ±	PRODUCT SPEC PRODUKTSPEZ.	-	NAME AMPMODU II STACKING PINHEADER AMPMODU II Distanzstiftleiste			
ANGLES/WINKEL ±	APPLICATION SPEC VERARBEITUNGSSPEZ.	-	SIZE	CAGE CODE	DRAWING NO ZEICHNUNGS-NR.	RESTRICTED TO NUR FUER
	WEIGHT GEWICHT	-	A4	00779	C-1394058	-
CUSTOMER DRAWING			/KUNDENZEICHNUNG		MASSSTAB	4:1
			BLATT		1 OF 1	VON 1
					A	