

6-1355688-5 AS SHOWN/wie gezeigt

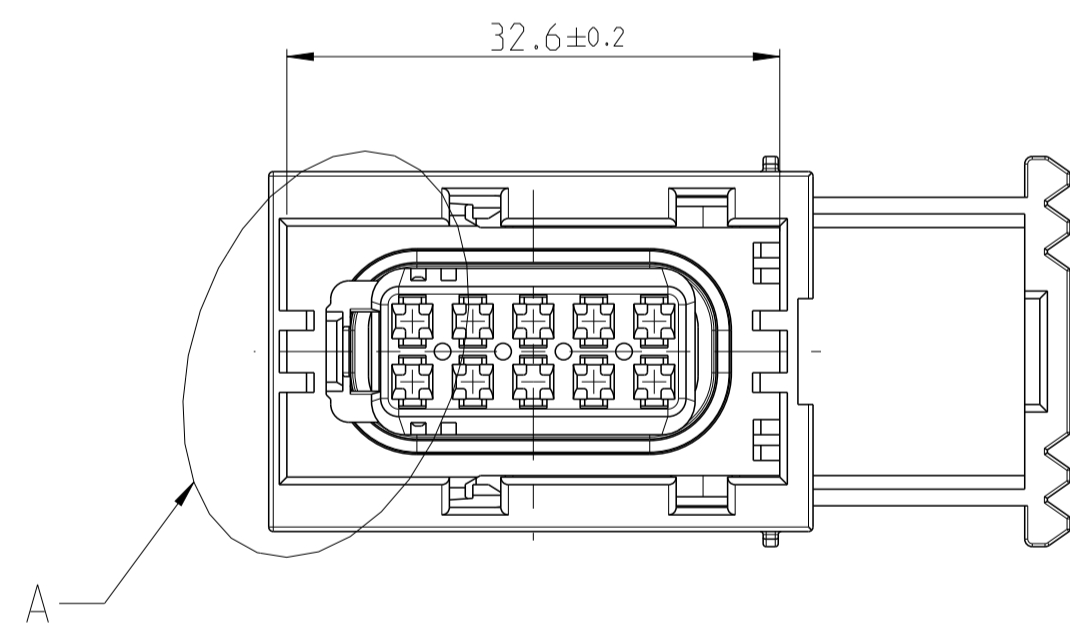

Kodierung F1 wie gezeichnet  
 CODING F1 AS SHOWN  
 schwarz / BLACK

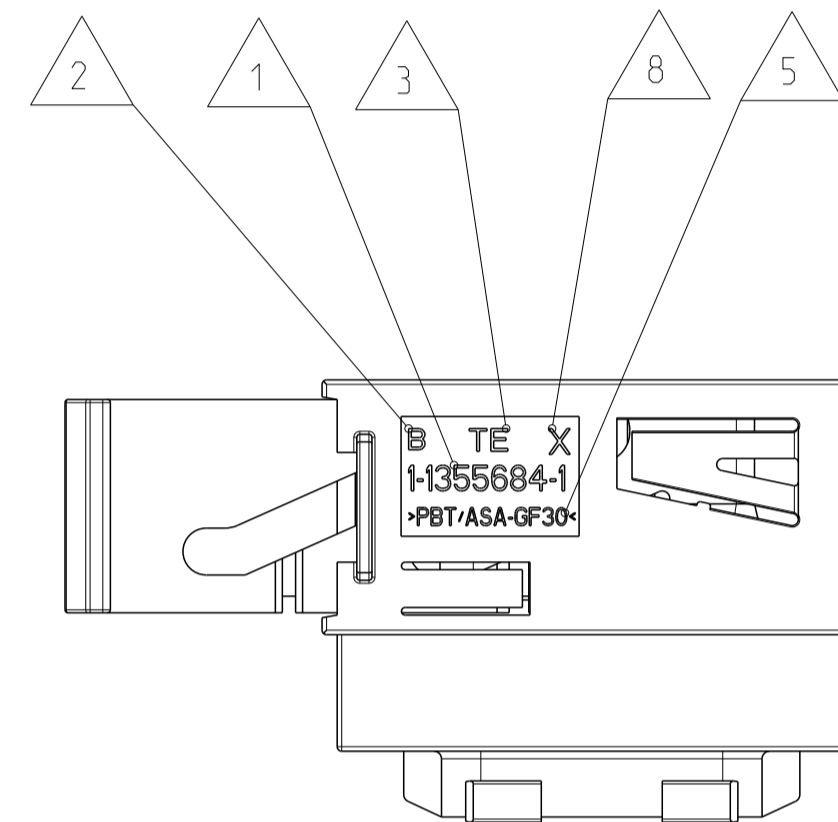
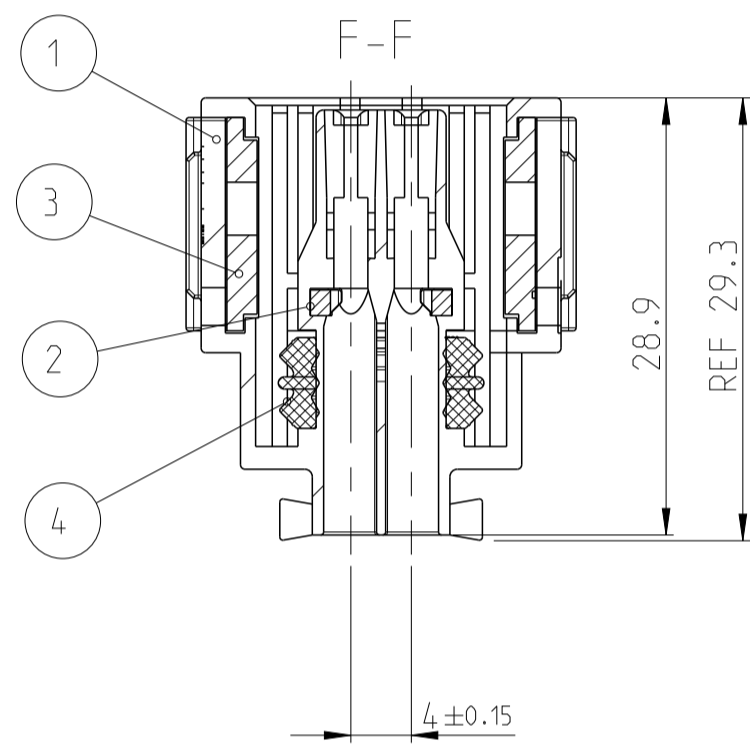
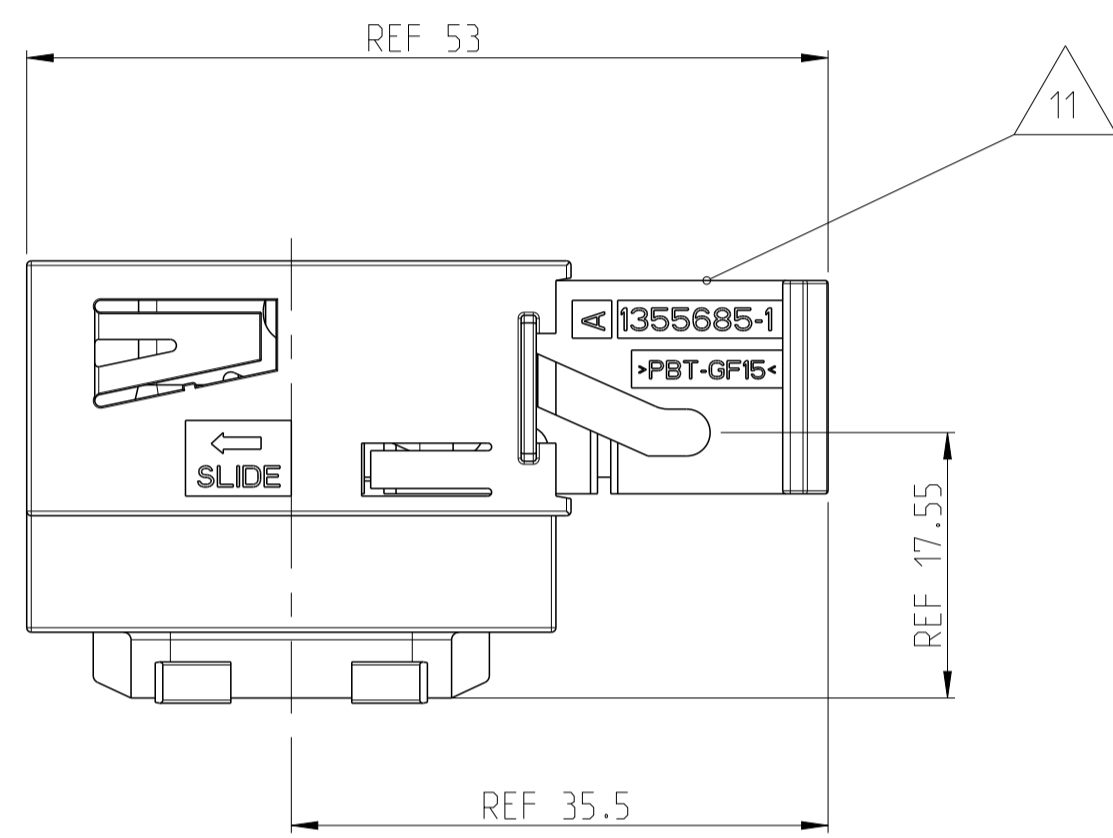
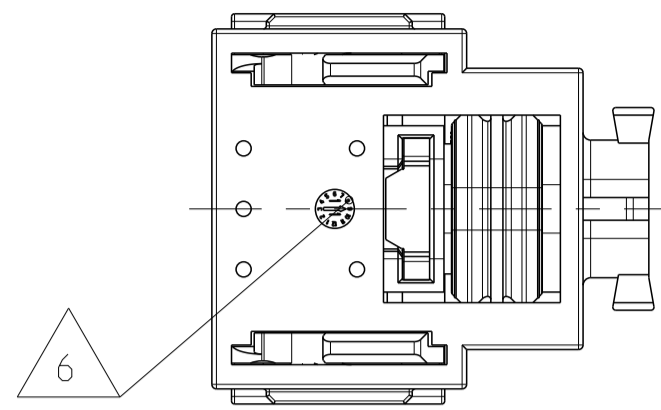
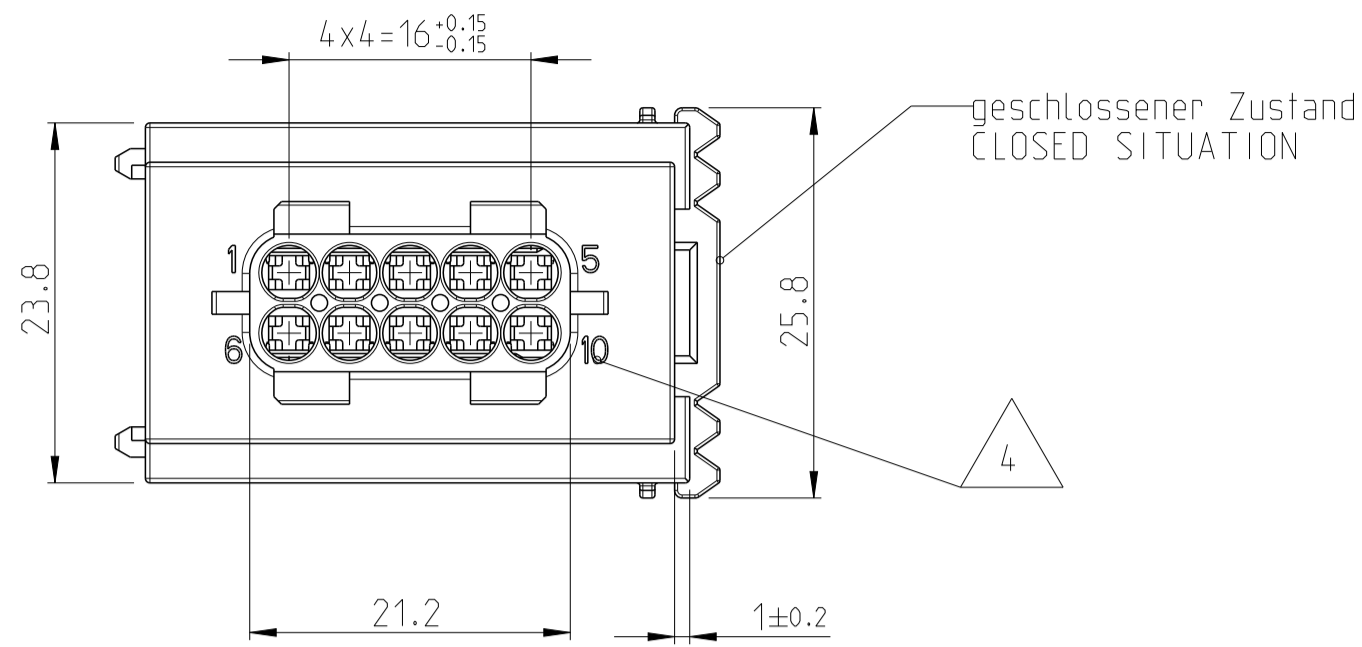
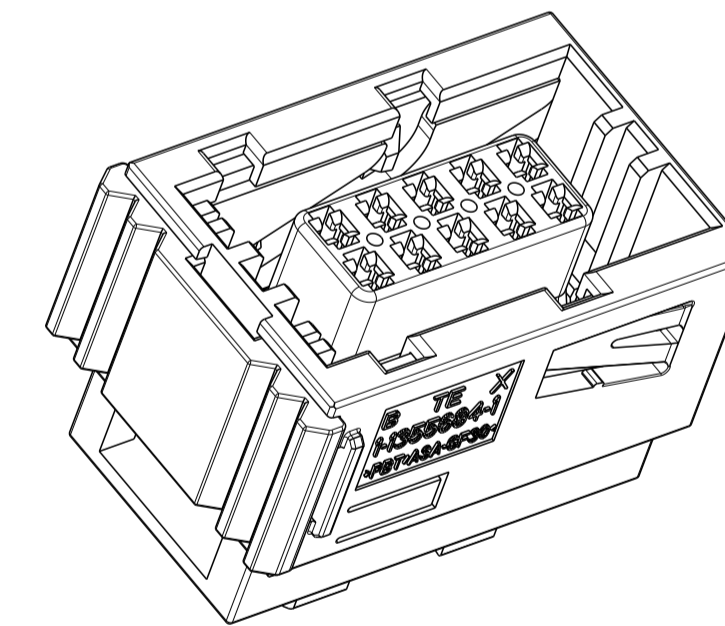
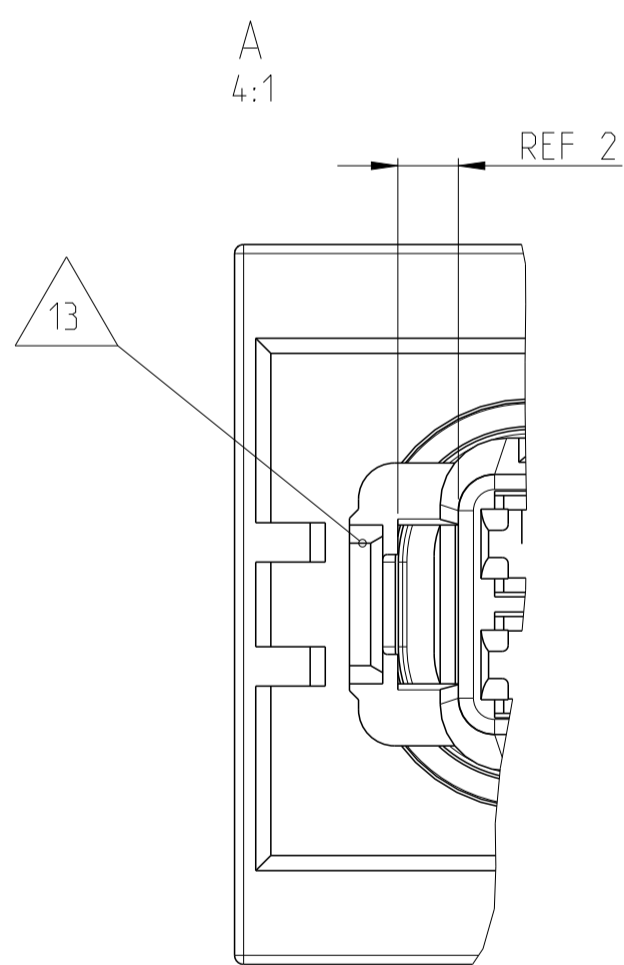

LOC	DIST	REVISIONS					
		P	LTN	DESCRIPTION	DATE	DWN	APVD
A1	-	B		NEW DRAWING	18JAN2012	SK	AK
		B1		SEE E-12-002578	09FEB2012	SK	AK
		B2		SEE E-13-004300	08MAR2013	SK	RH

NOTES

BEMERKUNGEN

- NV NOTE NOT VALID  
Bemerkung nicht verwendet
- 1 ORDER NUMBER  
BESTELL-NUMMER
- 2 REVISION NUMBER  
WERKZEUGÄNDERUNGSINDEX
- 3 TE LOGO
- 4 CONTACT CAVITY NUMBER  
KONTAKTKAMMERNUMMER
- 5 MATERIAL MARKING  
WERKSTOFFKENNZEICHNUNG
- 6 PRODUCTION DATE  
PRODUKTIONSDATUM
- 7 PRE-SERIES PART WITH CONDITIONAL RELEASE  
MARKED WITH CONDITIONING CLOCK  
INSTEAD OF DATE CLOCK  
VORSERIEANTEIL MIT BEDINGTER FREIGABE  
MARKIERT MIT ÄNDERUNGSUHR  
ANSTELLE DER DATUMSUHR
- 8 TOOL CAVITY MARKING  
NESTMARKIERUNG
- 9 PACKAGING: BULK MATERIAL IN CARDBOARD BOX  
VERPACKUNG: SCHÜTTGUT IN KARTON
- 10 PACKAGING: LAYERS IN CARDBOARD BOX  
VERPACKUNG: LAGENWEISE IN KARTON
- 11 DELIVERING SLIDE IN PRELOCKED OPEN POSITION  
ANLIEFERUNGSZUSTAND SCHIEBER OFFEN
- 12 MATING PART SEE SPEC. 114-18340  
ANSCHLUSSBAUTEIL SIEHE SPEZIFIKATION
- 13 SECONDARY LOCK IN OPEN POSITION FOR DELIVERY  
ANLIEFERUNGSZUSTAND ZWEITE KONTAKTSICHERUNG OFFEN

ORDER-NO.	REV. ASSY.	PCS.	POS.	NAME SINGLE PART	MATERIAL	SURFACE COLOUR
6-1355688-7	B	1	4	SEALING FOR 10 POS. MT3 HSG.	SILICON	ORANGE
		1	3	SLIDE FOR 10 POS. MT3 HSG.	PBT-GF15	RED
		1	2	RETAINER FOR 10 POS. MT3 HSG.	PBT-GF30	GREY
		1	1	MT3-REC.-HOUSING, 6 POS., COD F1	PBT/ASA-GF30	BLACK
6-1355688-5	B	1	4	SEALING FOR 10 POS. MT3 HSG.	SILICON	ORANGE
		1	3	SLIDE FOR 10 POS. MT3 HSG.	PBT-GF15	RED
		1	2	RETAINER FOR 10 POS. MT3 HSG.	PBT-GF30	GREY
		1	1	MT3-REC.-HOUSING, 10 POS., COD F1	PBT/ASA-GF30	BLACK

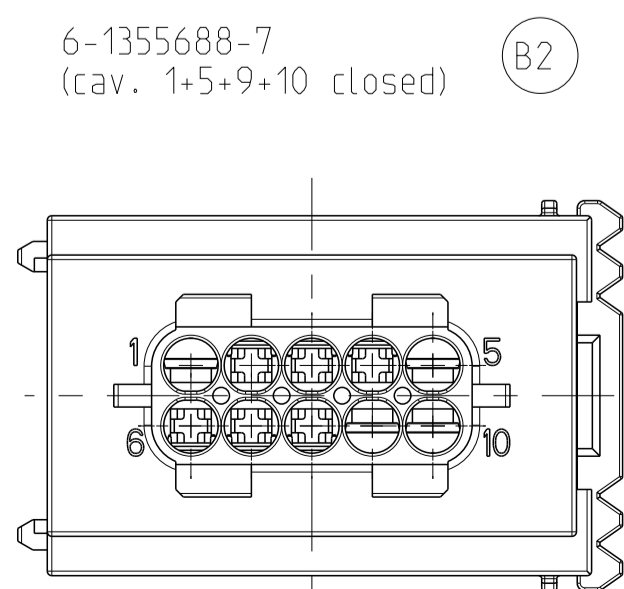

THIS DRAWING IS A CONTROLLED DOCUMENT. DWN: S. Kaethly 18JAN2012  
 CHK: A. Kettler 20JAN2012

**TE** Connectivity

NAME: MT3-REC. HOUSING, 10 POS.

PRODUCT SPEC: -

APPLICATION SPEC: -

SIZE: A1 CAGE CODE: 00779 DRAWING NO: 1355688

RESTRICTED TO: -

SCALE: 2:1 SHEET: 1 OF 1 REV: B2