

REVISIONS			
REV	DESCRIPTION	DATE	APPROVED
04 ₁	REVISED	2/18/71	<i>[Signature]</i>

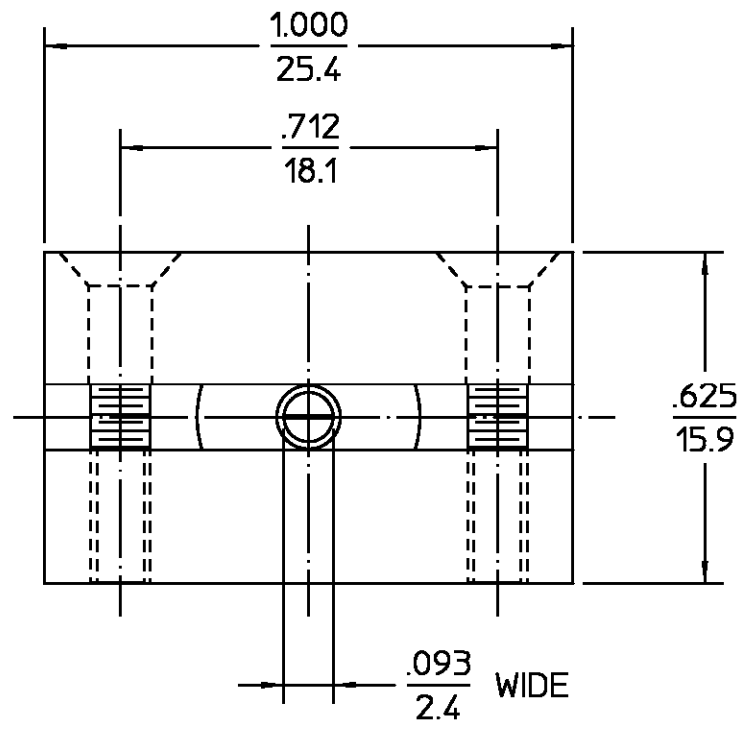
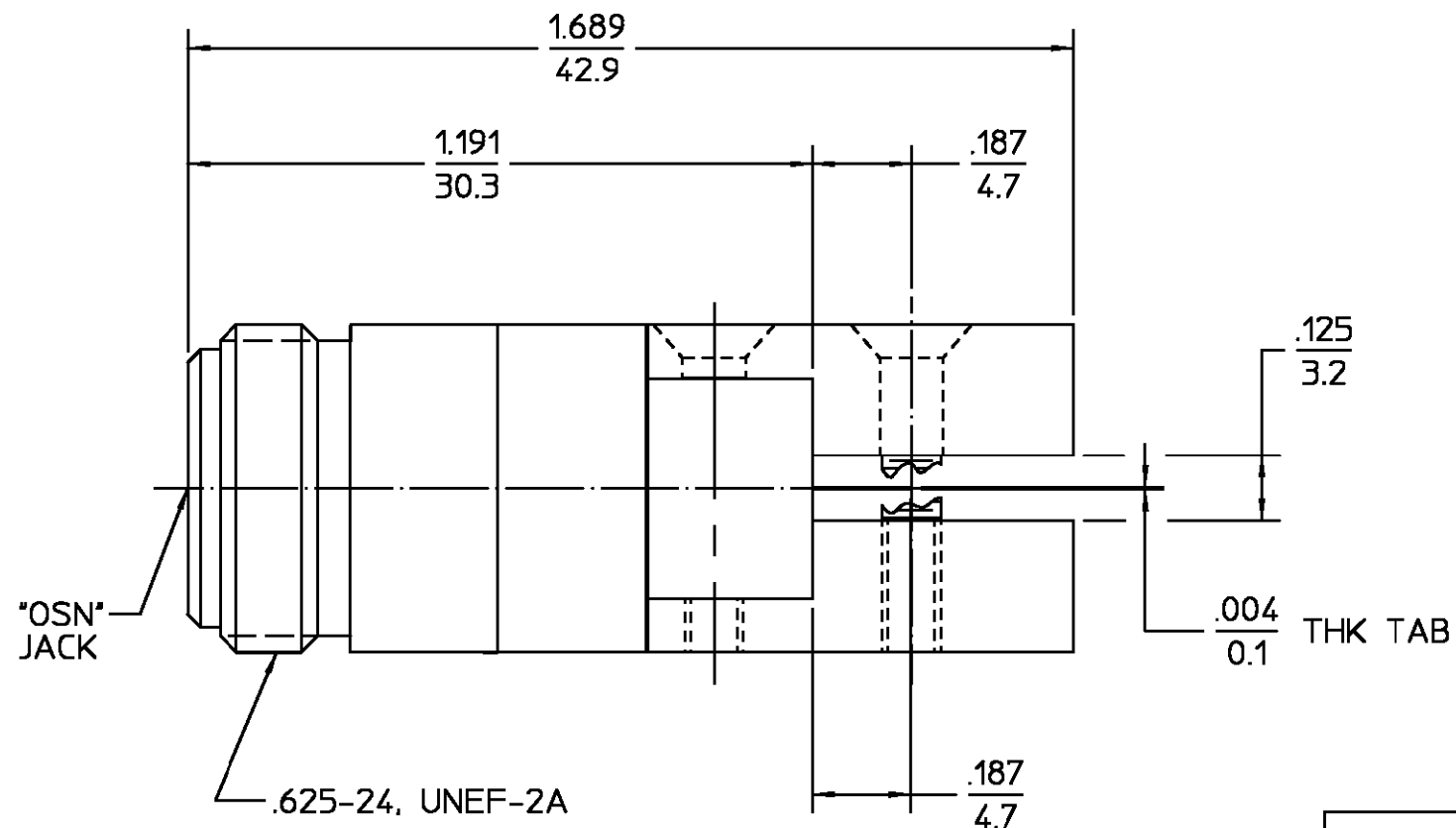

HOUSING	STAINLESS STEEL PER ASTM-A484 AND ASTM-582, TYPE 303	NICKEL PLATE PER QQ-N-290
BASE PLATES SCREWS	BRASS PER ASTM-B-16, HALF HARD	NICKEL PLATE PER QQ-N-290
DIELECTRIC	TFE FLUOROCARBON PER ASTM-D-1457	N/A
CENTER CONTACT	BERYLLIUM COPPER PER ASTM-B-196 OR ASTM-B-197, ALLOY C17300, CONDITION H	GOLD PLATE PER MIL-G-45204

COMPONENT	MATERIAL	FINISH
-----------	----------	--------

UNLESS OTHERWISE SPECIFIED DIMENSIONS ARE IN INCHES FRAC. ± 1/64 DEC. ± .005 ANGLES ± 1°	DRAWN BY EJC	DATE 1/12/71	AMP AMP Incorporated 140 Fourth Avenue Waltham, MA 02451-7599
	CHECKED BY PRB	1/18/71	
	APPD BY BWC	1/18/71	

These drawings and specifications are the property of M/A COM Interconnect Div. and shall not be reproduced or copied or used in whole or in part as the basis for the manufacture or sale of item(s) without written permission.	USE ASSY PROCEDURE	TITLE "OSN" STRAIGHT END LAUNCH JACK	
	NO. A.P. N/A	SIZE B	CODE IDENT NO. 26805
		SCALE 3:1	3070-1402-10
			SHEET 1 OF 1

- NOTES:
1. CAPTURED CENTER CONTACT
 2. DESIGNED FOR 1/8" THICK GROUND PLANE SPACING.

.XXX = in
XX.X = mm (REF)