

REVISIONS					
P	LTR	DESCRIPTION	DATE	DWN	APVD
H5	REVISED PER	ECN-22-166059	25JUL2022	RK	MF

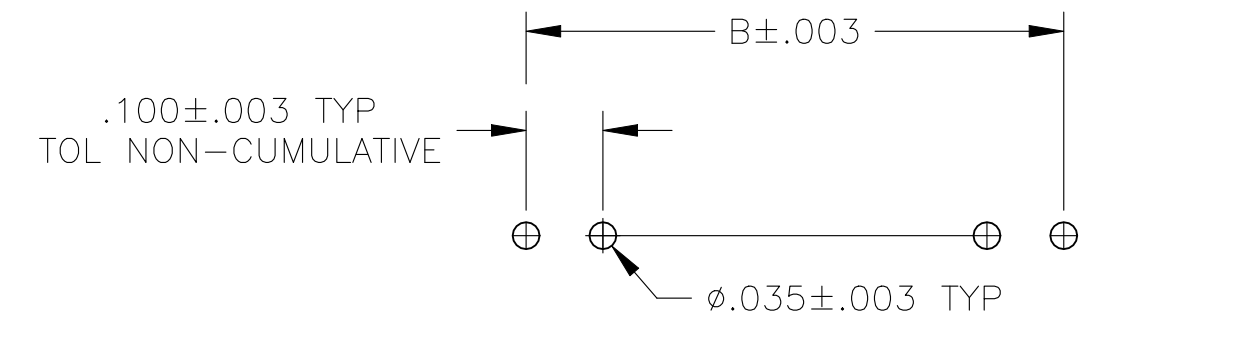
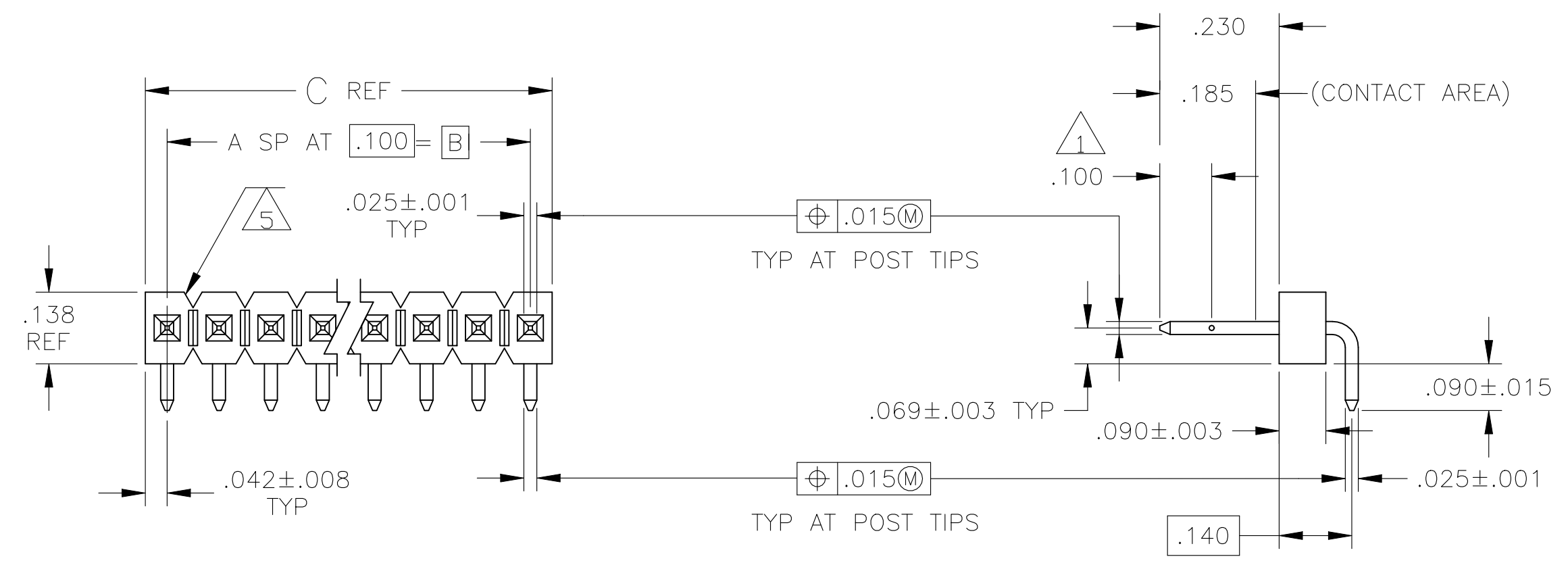

RECOMMENDED HOLE LAYOUT

- 1 POINT OF MEASUREMENT FOR PLATING THICKNESS
- 2 ASSEMBLY MAY BE BROKEN TO THE DESIRED NUMBER OF POSITIONS.
- 3 TRUE POSITION TOLERANCE OF THE POST TIPS APPLIES WHEN THE HEADERS ARE HELD FLAT AGAINST THE PRINTED CIRCUIT BOARD
- 4 .000030 GOLD IN CONTACT AREA, .000100-.000200 MATTE TIN-LEAD ON SOLDER TAIL, ALL OVER .000050 NICKEL
- 5 BREAKAWAY NOTCH ANGLE CAN BE ORIENTED TO THE RIGHT (AS SHOWN) OR TO THE LEFT
- 6 .000030 GOLD IN CONTACT AREA, .000100-.000200 MATTE TIN ON SOLDER TAIL, ALL OVER .000050 NICKEL
- 7 HIGH TEMPERATURE CONFIGURATION
- 8 OBSOLETE PARTS: OBSOLETE CIS STREAMLINING PER D.RENAUD/D.SINISI

△	△	3.984	3.900	39	40	9-103765-0
△	△	3.484	3.400	34	35	8 - -5
△	△	2.984	2.900	29	30	8 - -0
△	△	2.484	2.400	24	25	7 - -5
△	△	1.984	1.900	19	20	7 - -0
△	△	1.484	1.400	14	15	6 - -5
△	△	1.384	1.300	13	14	6 - -4
△	△	1.284	1.200	12	13	6 - -3
△	△	1.184	1.100	11	12	6 - -2
△	△	1.084	1.000	10	11	6 - -1
△	△	.984	.900	9	10	6 - -0
△	△	.884	.800	8	9	5 - -9
△	△	.784	.700	7	8	5 - -8
△	△	.684	.600	6	7	5 - -7
△	△	.584	.500	5	6	5 - -6
△	△	.484	.400	4	5	5 - -5
△	△	.384	.300	3	4	5 - -4
△	△	.284	.200	2	3	5 - -3
△	△	.184	.100	1	2	5 - -2
△	△	.084			1	5-103765-1
△	△	3.984	3.900	39	40	4-103765-0
△	△	3.884	3.800	38	39	3 - -9
△	△	3.784	3.700	37	38	3 - -8
△	△	3.684	3.600	36	37	3 - -7
△	△	3.584	3.500	35	36	3 - -6
△	△	3.484	3.400	34	35	3 - -5
△	△	3.284	3.300	33	34	3 - -4
△	△	3.284	3.200	32	33	3 - -3
△	△	3.184	3.100	31	32	3 - -2
△	△	3.084	3.000	30	31	3 - -1
△	△	2.984	2.900	29	30	3 - -0
△	△	2.884	2.800	28	29	2 - -9
△	△	2.784	2.700	27	28	2 - -8
△	△	2.684	2.600	26	27	2 - -7
△	△	2.584	2.500	25	26	2 - -6
△	△	2.484	2.400	24	25	2 - -5
△	△	2.384	2.300	23	24	2 - -4
△	△	2.284	2.200	22	23	2 - -3
△	△	2.184	2.100	21	22	2 - -2
△	△	2.084	2.000	20	21	2 - -1
△	△	1.984	1.900	19	20	2 - -0
△	△	1.884	1.800	18	19	1 - -9
△	△	1.784	1.700	17	18	1 - -8
△	△	1.684	1.600	16	17	1 - -7
△	△	1.584	1.500	15	16	1 - -6
△	△	1.484	1.400	14	15	1 - -5
△	△	1.384	1.300	13	14	1 - -4
△	△	1.284	1.200	12	13	1 - -3
△	△	1.184	1.100	11	12	1 - -2
△	△	1.084	1.000	10	11	1 - -1
△	△	.984	.900	9	10	1 - -0
△	△	.884	.800	8	9	1 - -9
△	△	.784	.700	7	8	1 - -8
△	△	.684	.600	6	7	1 - -7
△	△	.584	.500	5	6	1 - -6
△	△	.484	.400	4	5	1 - -5
△	△	.384	.300	3	4	1 - -4
△	△	.284	.200	2	3	1 - -3
△	△	.184	.100	1	2	1 - -2
△	△	.084			1	103765-1

REMARKS	PLATING	C	B	A	NO OF POS	ASSEMBLY PART NUMBER

THIS DRAWING IS A CONTROLLED DOCUMENT.

DIN L. D. RINGLEY 24JUL85
CHK R. FLICKER 24JUL85

APVD R. FLICKER 24JUL85

NAME ASSY, MOD II, HEADER, BREAKAWAY, SR, RIGHT ANGLE 100, WITH .025 SQUARE POSTS

PRODUCT SPEC

APPLICATION SPEC

SIZE A1 CAGE CODE 00779 DRAWING NO 103765

RESTRICTED TO

MATERIAL HOUSING: TARE REMOVED THERMOPLASTIC COLOR: BLACK POSTS: COPPER ALLOY FINISH SEE TABLE WEIGHT --

CUSTOMER DRAWING SCALE 4:1 SHEET 1 OF 1 REV H5