

REVISIONS					
ZONE	LTR	ECN	DESCRIPTION	DATE	APPROVED
	W	23746	003-0360-0002 WAS 003-0933-0002 003-0205-0001 WAS 003-0970-0001 003-0153-0001 WAS 003-0971-0001 003-0163-0001 WAS 003-0805-0001 .700 REF. WAS .692.04 FROM FACE OF NUT OTHERS SEE E.C.N.	12/24/78	RAM
	WI	1497	UPDATE FORMAT	3/1/02	AW

CABLE ACCEPTANCE DIM'S
 JACKET .088 DIA. MAX.
 SHIELD .061 DIA. MAX.
 DIELECTRIC .041 DIA. MAX.
 CENTER COND. .015 DIA. MAX.

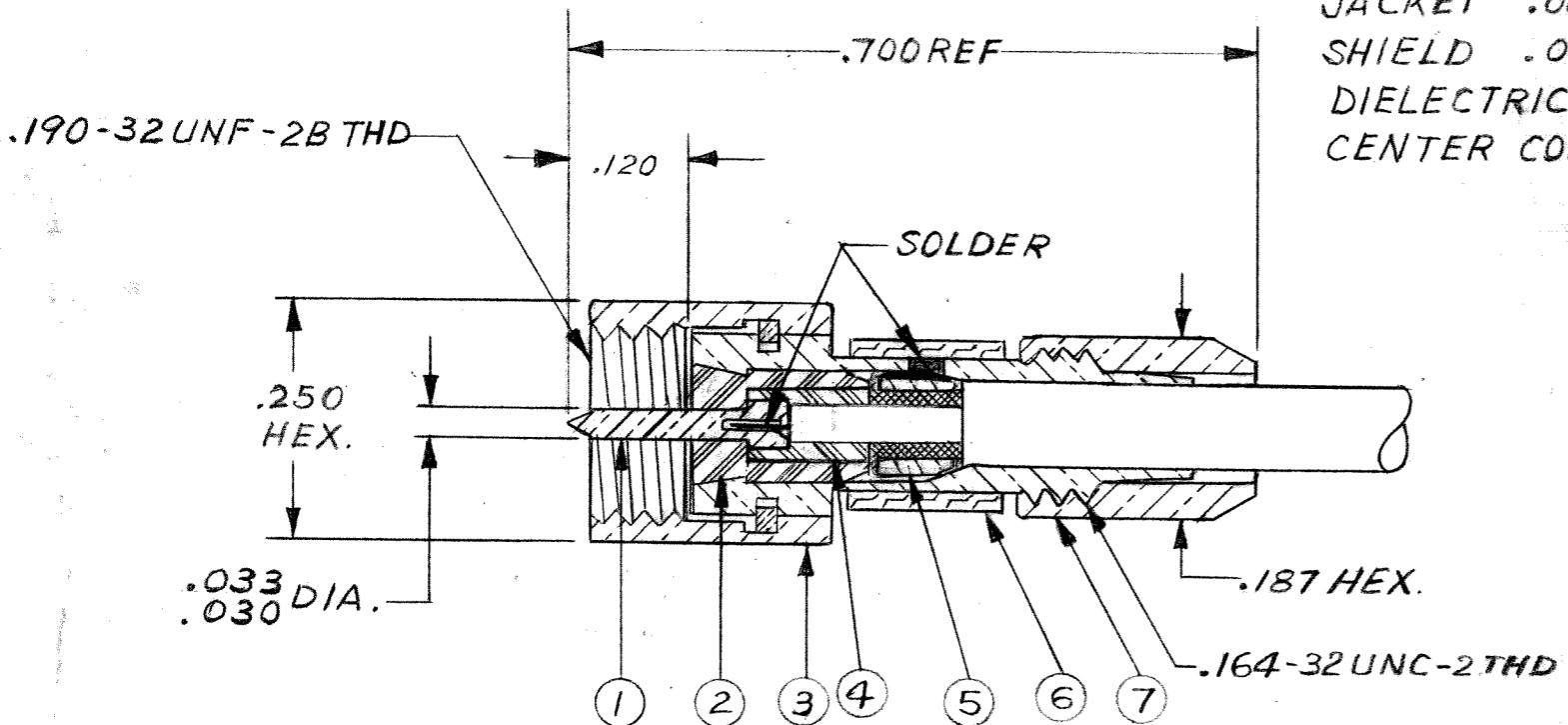

Tyco Dwg 1-1532153-9
 Micro P/N 032-0155-0001

- NOTES: UNLESS OTHERWISE SPECIFIED
1. THIS CONNECTOR MATES WITH ALL JACKS & RECEPTACLES IN THE S-50 SERIES AS LISTED IN MALCO CATALOG.
 2. USE SPECIAL TOOL # 010-0003-0000 FOR ASSEMBLY.
 3. SILVER PLATE .0002 MIN. PER QQ-S-365. TYPE II, GRADE A.
 4. GOLD PLATE PER MIL-G-45204. TYPE II, GRADE C, CL. I.
 5. FOR ASSY. INSTRUCTIONS. USE RF-ASMB-89. BUT PLACE RETAINING NUT ON CABLE IN PLACE OF B.R. CAP. SOLDER THE JERK RING TO FERRULE.

3	1	003-0756-0001	RETAINING NUT	BRASS PER QQ-B-626	7
	1	003-0826-0000	SLEEVE (BLACK)	HEAT SHRINK SLEEVE	6
3	1	003-0163-0001	JERK RING	BRASS PER QQ-B-626	5
	1	003-0153-0001	INSULATOR	TEFLON PER L-P-403	4
3		003-0757-0001	FERRULE	BRASS PER QQ-B-626	
		003-1081-0000	SNAP RING	BERYLL. COPPER QQ-C-530	
3		003-0803-0001	NUT	BRASS PER QQ-B-626	
	1	003-0795-0001	HOUSING SUB-ASSY		3
	1	003-0205-0001	INSULATOR	TEFLON PER L-P-403	2
4	1	003-0360-0002	PIN	BRASS PER QQ-B-626	1
	QTY.	PART NO.	DESCRIPTION	MATERIAL & SPEC.	ITEM NO.

PARTS LIST

UNLESS OTHERWISE SPECIFIED DIMENSIONS ARE IN INCHES FRACTIONS DECIMALS ANGLES ± .XX ± ± .XXX ± .010		CONTRACT NO.		MALCO A MICRODOT COMPANY, INC. 220 PASADENA AVE., SO. PASADENA, CALIF. 91030	
MATERIAL NOTED		APPROVALS DRAWN E.H. CHECKED C.H. PR. ENG. B.M.	DATE 11/78 11/14/78 12-20-78	PLUG	
FINISH NOTED		APPROVED	SIZE B	CODE IDENT NO. 98278	DRAWING NO. 032-0155-0001
NEXT ASSY		USED ON		SCALE 5 X	SHEET 1 OF 1
APPLICATION		DO NOT SCALE DRAWING		These drawings and specifications are the property of Microdot Inc., are issued in strict confidence and shall not be divulged, be reproduced or copied, or used as the basis for the manufacture or sale of any article without written permission of Microdot Inc.	