

LOC	DIST	REV	DATE	APPV
A1	-	A	26 JUN 2013	DR CE
		A1	11 SEP 2017	PP CF

DELIVERY CONDITION AS SHOWN
 Lieferzustand wie gezeigt

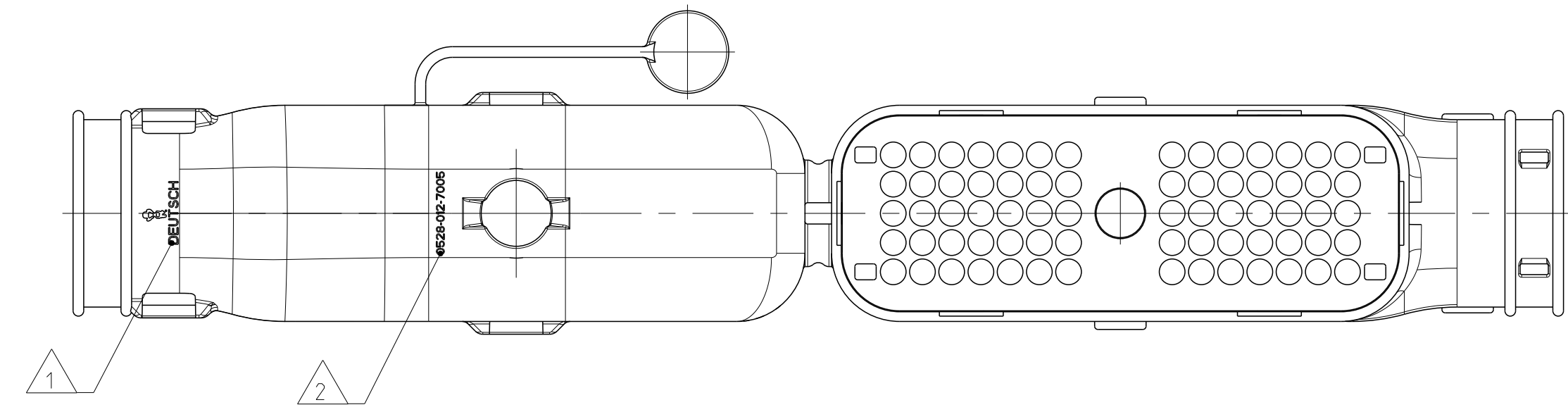

- NOTES
 Bemerkungen
- 1 DEUTSCH LOGO
DEUTSCH Logo
 - 2 DEUTSCH PART-NO
DEUTSCH Teil-Nr.
 - 3 PRODUCTION DATE
Produktionsdatum
 - 4 BULK PACKAGING IN PLASTIC BAG
Schueffgut im Plastikbeutel
 - 5 MALFUNCTION CAUSED BY LAQUER IS
NOT COVER BY TE WARRANTY
Funktionsbeeinträchtigung durch Lackieren liegt
nicht im Einfluss und Gewährleistungsumfang von TE
 - 6 MATERIAL MARKING ACCORDING TO VDA 260
Werkstoffkennzeichnung nach VDA 260
 - 7 MOULD CAVITY MARKING (IF NECESSARY)
Nestmarkierung (falls notwendig)
 - 8 BASED ON THE HINGE MECHANISM OF THE CAP,
THE DELIVERY CONDITION CAN BE DIFFERENT
TO THE SHOWN STATUS.
Basierend auf dem Klappmechanismus der Kappe, kann der
Lieferzustand von der dargestellten Ansicht abweichen.
 - 9 MATED WITH DRC16-70S
Passend zu DRC16-70S

CLOSED (MOUNTED) CONDITION AS SHOWN
 Geschlossener (montierter) Zustand wie gezeigt

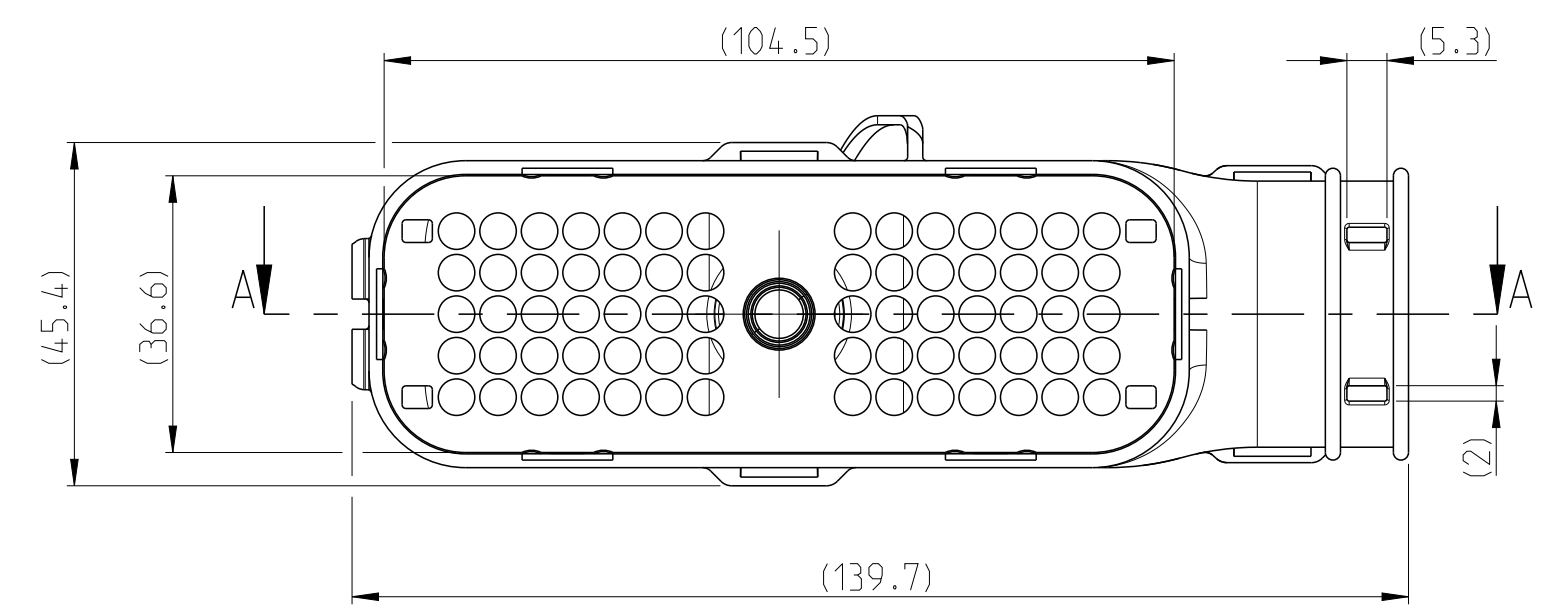

SECTION A-A
 Schnitt

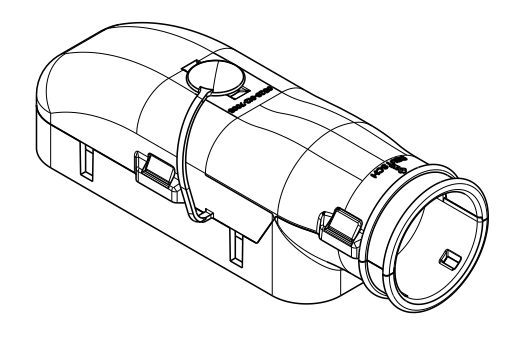
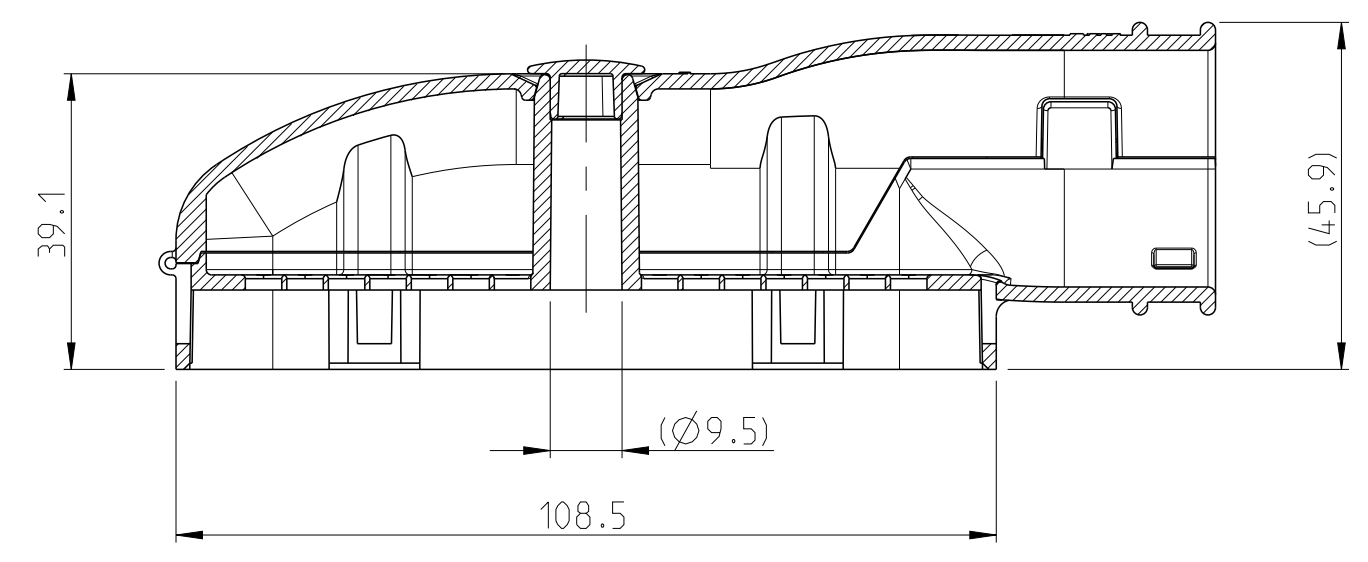
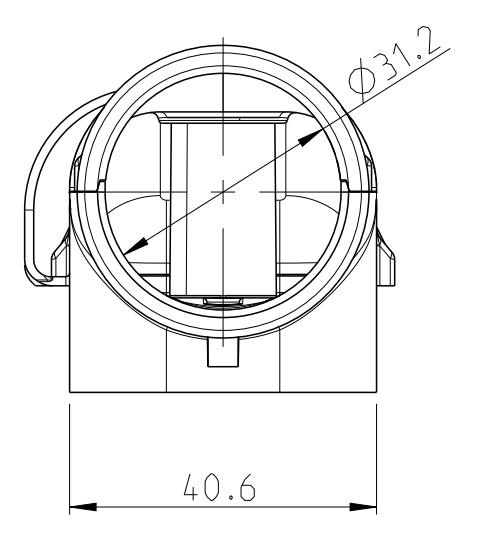

SCALE 1:2
 Maßstab

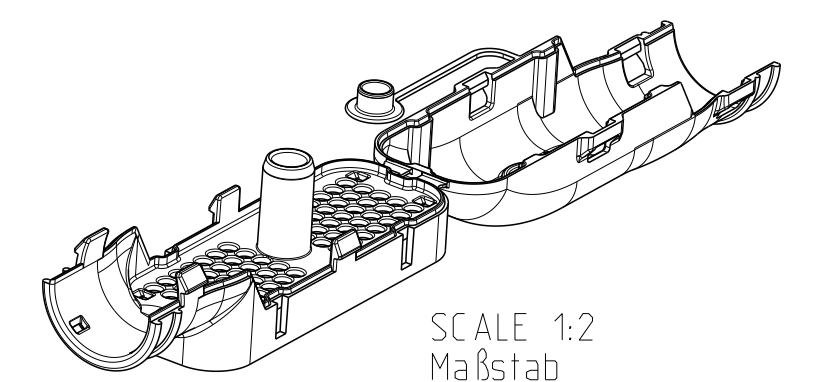
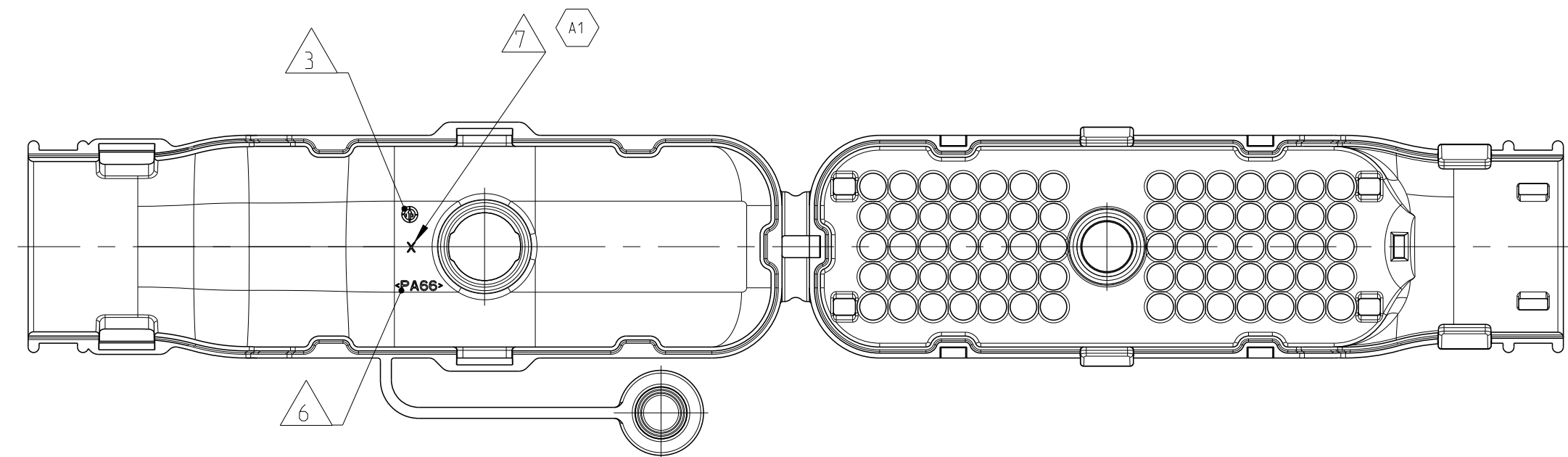
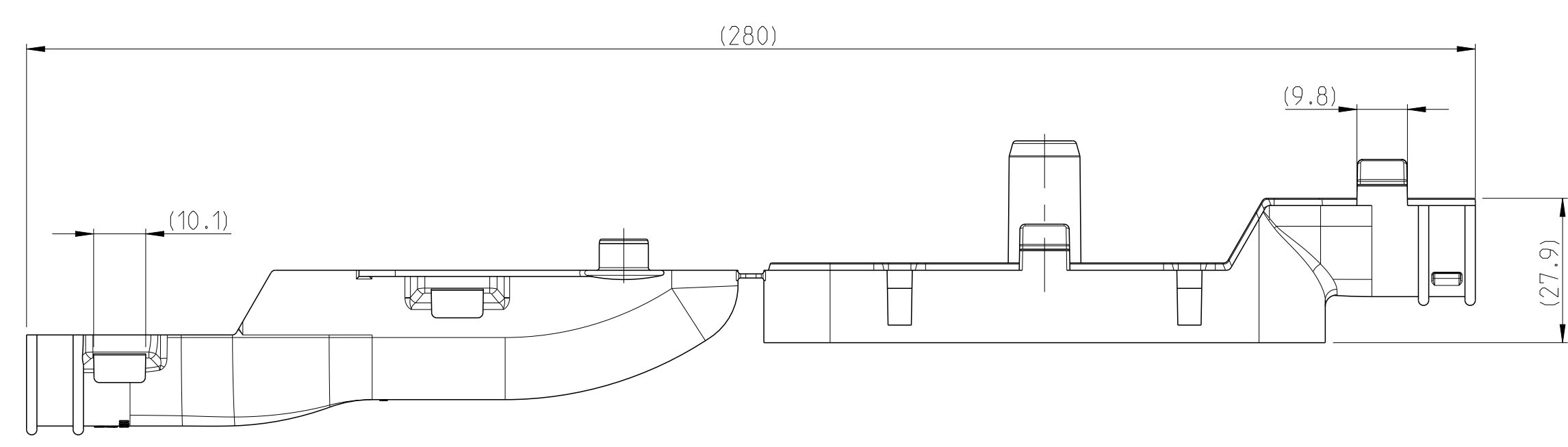

SCALE 1:2
 Maßstab

ORDER-NO. Bestell-Nr.	REV.	WEIGHT (g)	MATERIAL	COLOUR Farbe	DESCRIPTION Beschreibung	ITEM
0528-012-7005	A	44.68	NYLON 6/6	BLACK	COVER WITHOUT RIBS Kappe ohne Rippe	1

DIMENSIONS: MASSENEHMEN: mm		TOLERANCES UNLESS OTHERWISE SPECIFIED: TOLERANZEN GEMAESS GPS (ISO STANDARDS): ALLE DIMENSIONEN	
1	±0.1	1	±0.1
2	±0.1	2	±0.1
3	±0.1	3	±0.1
4	±0.1	4	±0.1
5	±0.1	5	±0.1
6	±0.1	6	±0.1
7	±0.1	7	±0.1
8	±0.1	8	±0.1
9	±0.1	9	±0.1

DIESE ZEICHNUNG IST EIN KONTROLLIERTES DOKUMENT. BEMASSUNGEN UND TOLERANZEN GEMAESS GPS (ISO STANDARDS).		THIS DRAWING IS A CONTROLLED DOCUMENT. DIMENSIONING AND TOLERANCING PER GPS (ISO STANDARDS).	
DWN: D. RAJASHEKAR CHK: C. FINZER		26 JUN 2013 27 JUN 2013	
APVD: E. ERBERWEIN		27 JUN 2013	
NAME: COVER, DRC16-70S-BS090 Kappe, DRC16-70S-BS090 BACKSHELL STRAIGHT (90DEG)		RESTRICTED TO NUR FÜR	
SCALE: 1:1		SHEET 1 OF 1	