

WAREHOUSE AUTOMATION

Connectivity Solutions That Support
Continuous Warehouse Operations



LET'S CREATE THE CONNECTIONS THAT COUNT.

TE Connectivity (NYSE : TE L) is a \$13 billion world leader in connectivity. The company designs and manufactures products at the heart of electronic connections for the world's leading industries, including automotive, energy and industrial, broadband communications, consumer devices, healthcare, and aerospace and defense. TE Connectivity's long-standing commitment to innovation and engineering excellence helps its customers solve the needs for more energy efficiency, always-on communications, and ever-increasing productivity. With nearly 90,000 employees in over 50 countries, TE Connectivity makes connections the world relies on to work flawlessly every day.

To connect with the company, visit te.com.

EVERY VISION IS MORE THAN A COLLECTION OF GOOD IDEAS.

Welcome to Warehouse Automation. TE Connectivity (TE) is a major player in plant and mechanical engineering and industrial automation. We have been maintaining partnerships with leading companies in the automation industry in key markets such as Germany, Japan, the United States, and China for around six decades.

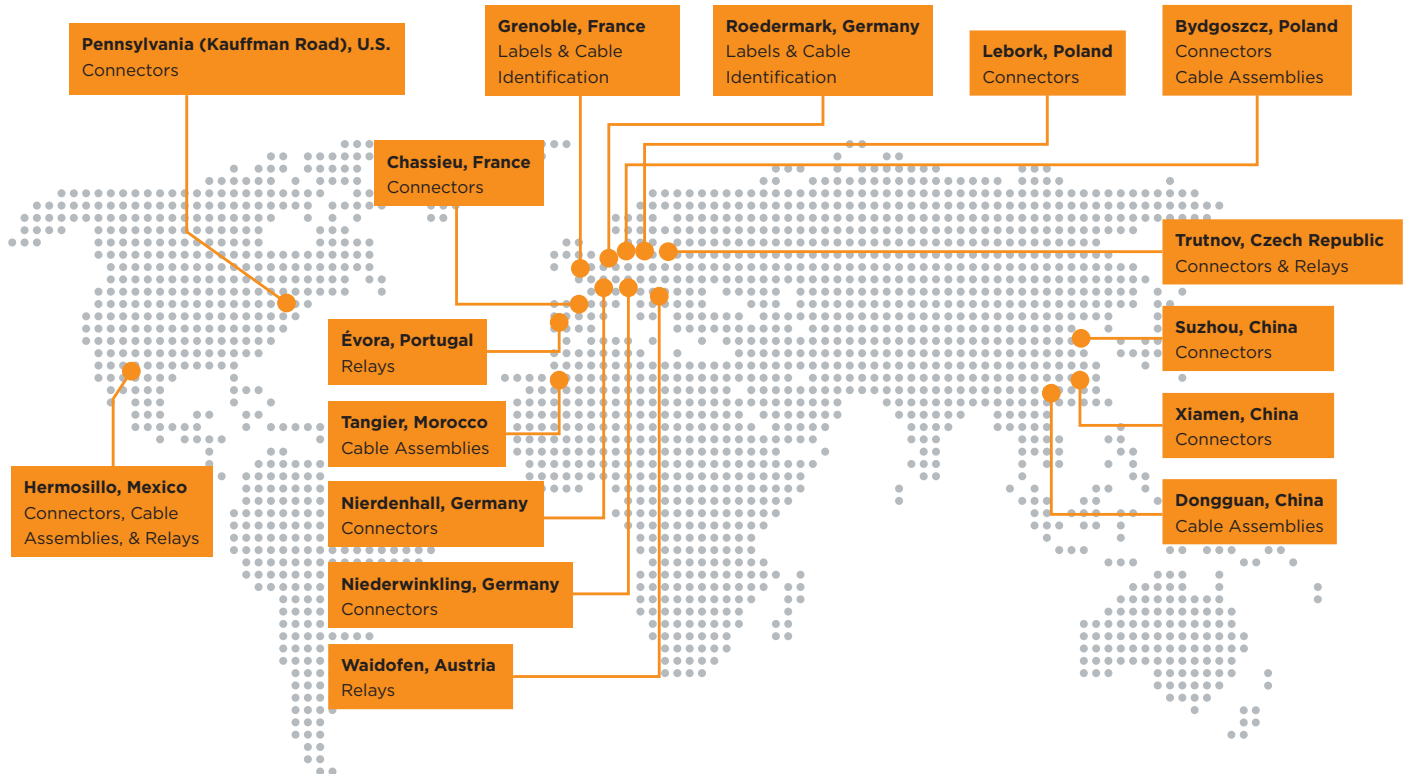

COUNT ON TE. FROM DESIGN TO DELIVERY TO WHAT COMES NEXT.

Industrial production is increasingly driven by higher automation. By improved safety. By greater energy efficiency. You can count on TE to work with you every step of the way to develop solutions for every aspect of your production processes.

TE designs and manufactures products and solutions that connect and protect the flow of power, data, and signal in every aspect of our lives. We enable smarter, faster, better technologies to connect materials to end products — for virtually all areas of life. This has made us a globally successful company: a world leader in automation and control technology. At TE, we empower engineers to solve today's toughest challenges.

COUNT ON PRODUCTS THAT HELP YOU COMPETE.

Our broad electromechanical and electronic experience ranges from simple machinery equipment to fully integrated factory automation and process solutions. For applications in a wide variety of production environments — and always extremely close to the needs of our customers from a wide range of sectors.

With TE as your innovation partner, we can help you find the components you need to create and operate a cost-efficient and highly reliable production process. We are at our best when we work with your product design and process management teams to get the job done right from the start. We also offer continuous improvement programs that give you a real competitive advantage. Because you cannot achieve greater productivity and efficiency without better connectivity.

SMART TECHNOLOGY FOR TODAY AND TOMORROW.

Every vision starts with a big idea — and the absolute desire to face new challenges, develop new solutions, and pursue new approaches. Our mission is to provide support for problem solvers in pursuing these approaches throughout the world. We work together to develop outstanding visions from big ideas for innovations that make our world better.

THE TE MANIFESTO

01.

IDENTIFYING OPPORTUNITIES.

FOR PERFECT INTEGRATION; AS EVERY CONNECTION COUNTS.

02.

TAKING UP CHALLENGES.

A NEW GENERATION OF PRODUCTS; FOR A NEW GENERATION OF CUSTOMER NEEDS.

03.

CREATING SOLUTIONS.

YOU CAN RELY ON TE; AND ON INTERCONNECT SOLUTIONS THAT MEET THE CHALLENGES OF TOMORROW TODAY.

04.

TURNING AIMS INTO REALITY.

GREATER PRODUCTIVITY, GREATER EFFICIENCY, AND GREATER COST-EFFECTIVENESS; FOR YOU, YOUR CUSTOMERS, AND A SMARTER WORLD.

Industry 4.0: The Next Industrial Revolution.

The rising levels of automation in today's warehouses present major challenges. Now more than ever, automation solutions need to impress with their profitability through long operating times, optimized energy efficiency, and lower costs.

Automated warehouses need to improve in every aspect — both now and in the future — with increased productivity, flexibility, adaptability, more automation, and smarter connections. TE offers innovative solutions for enhanced connectivity. From automating transportation and organization to delivery of materials within the facility, in the harshest warehouse conditions, anywhere in the world.

Connections for a New Generation.

Digital technologies of today are key to the automated warehouses of tomorrow. These next-generation warehouses will boast significant optimizations in productivity and delivery and perfectly integrate and network the internet, robots, employees, and systems.

Our engineers here at TE are pioneers in this revolution. We are using our innovations to play a key role in turning the next level of warehouse automation into reality even faster.

SEAMLESS OPERATIONS.

BY AUTOMATING THE TRANSPORTATION, ORGANIZATION,
AND DELIVERY OF MATERIALS, YOU COULD EXCEED
GOALS FOR PRODUCTIVITY AND DELIVERY.

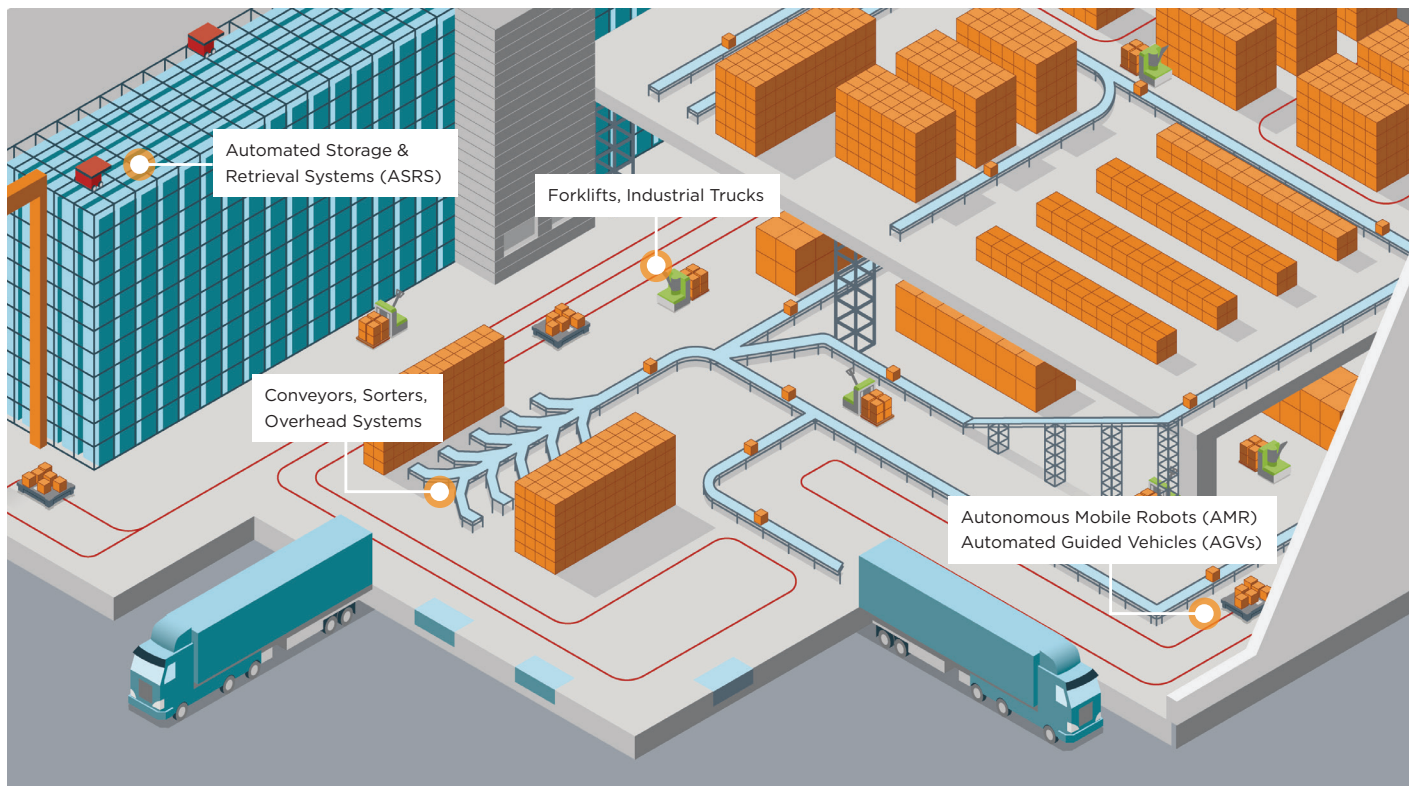



WAREHOUSE AUTOMATION STARTS WITH OPTIMIZED OPERATIONS

And Optimized Operations Start with TE

From the e-commerce boom for consumer goods, including everything from toys, clothing, and frozen and refrigerated foods, to the ongoing storage of raw materials, semi-finished goods, and out-of-season farm products, demand for warehousing space has never been higher. Companies struggling with the labor shortage are looking for advantages in warehouse automation to help them keep up and thrive in the new normal. Thanks to rapid developments in sensors and technology, warehouse automation equipment has experienced significant growth. These new products and solutions can help optimize all warehouse operations, including distribution and fulfillment centers, by automating key tasks such as storing, retrieving, and moving inventory.

Significant optimizations in productivity and delivery can be gained by simply automating the transportation, organization, and delivery of materials within a facility. While in most warehouses there will continue to be (for the foreseeable future, at least) a need for robot and human collaboration, the latest generation of automated robots can handle increasingly complex tasks within a wide range of warehouse environments.

Robots can now be used for internal transportation tasks, such as routine material deliveries. These robots include

automated guided vehicles (AGVs) and autonomous mobile robots (AMRs). AMRs are more sophisticated robots with smart navigation and higher flexibility, while AGVs require guidance from wires or strips.

Today there are also highly integrated systems with robots that work together to handle material storage, make smart decisions on material placement and inventory rotation, and fulfill tasks such as pickup and shipping preparation. These are called automatic storage and retrieval systems (ASRS).

EVERY CONNECTION COUNTS. WE SUPPORT CONTINUOUS OPERATIONS.

Robotic systems are the future of warehouse automation, but so is reliable connectivity. TE's portfolio for warehouse automation, including Heavy Duty Connectors (HDC), motor connectivity, power and signal distribution, relays, field installable solutions, and data/communications (Ethernet connectors) plays a central role in optimizing warehouse operations.

We continue to drive innovation in the simplest and most complex technologies by offering highly engineered connectivity solutions that support continuous operations.

As a leader in state-of-the-art contactors and connectivity for efficient battery and charging management as well as sensors and connectors for motors and drives, TE is engineering a wide variety of technological advancements to help customers meet the increasing demand within automated warehouses.

TE engineers are designing efficient, reliable, and durable components for today's electric powertrain systems, which are the foundation for successful automated warehouse operations, powering all of the systems responsible for meeting increased productivity needs. Our team designs, engineers, and manufactures small yet mighty connectors, cables, and components necessary for low-payload robots to run 24/7/365. Our products are sturdy and rugged enough for the industrial environment, but also capable of transmitting the high-speed data in real time that tech-savvy warehouse managers depend on.

We also provide industry-leading motor and battery connectivity solutions and contactors as well as rugged connectivity solutions for vehicle wiring — all from known brands such as AMP, DEUTSCH, KILOVAC, SCHRACK, Potter & Brumfield (P&B), KISSLING, Corcom, ENTRELEC, and Intercontec.

Due to our long experience with high-speed and small-form factor connectivity, TE can help you stay ahead of miniaturization trends and increasing data requirements. And, with our field-installable connector solutions, you can realize flexible installations to help reduce planning and logistics costs.

With a global manufacturing footprint, logistics, and support network, TE enables multinational players to source in-location worldwide, where our field application experts can advise on product choice, evaluate architecture, and help optimize the function and cost of warehouse equipment.

EQUIPMENT AND APPLICATIONS FOR TE COMPONENTS

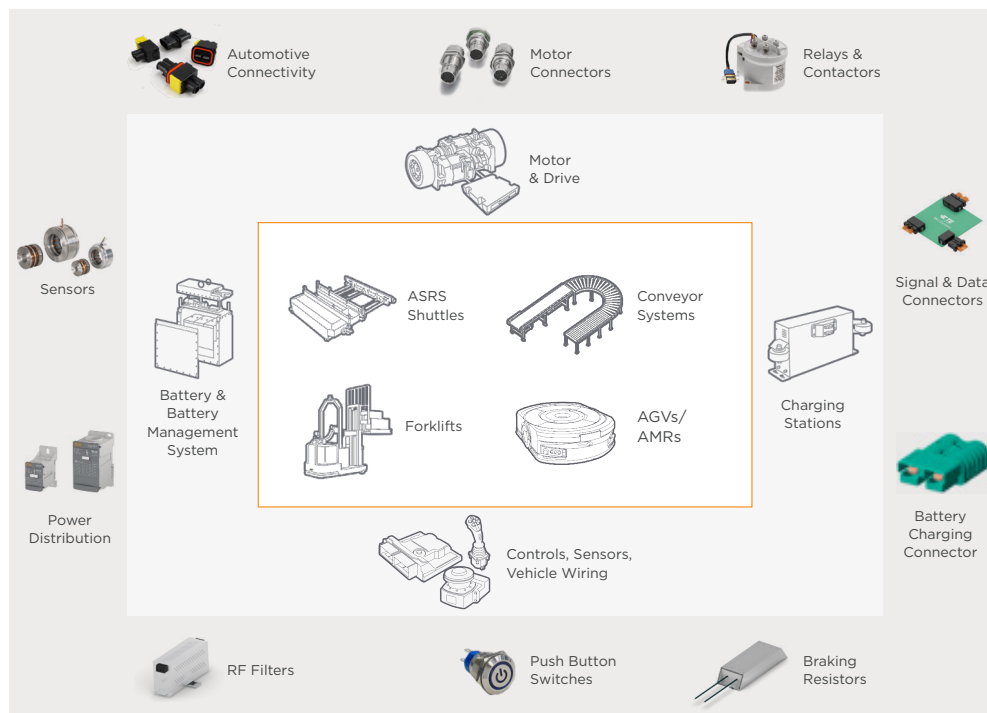

PRODUCT OVERVIEW

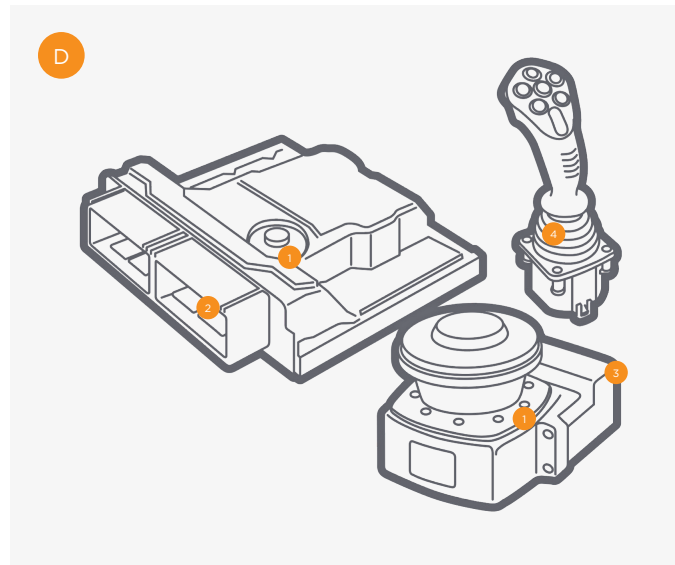
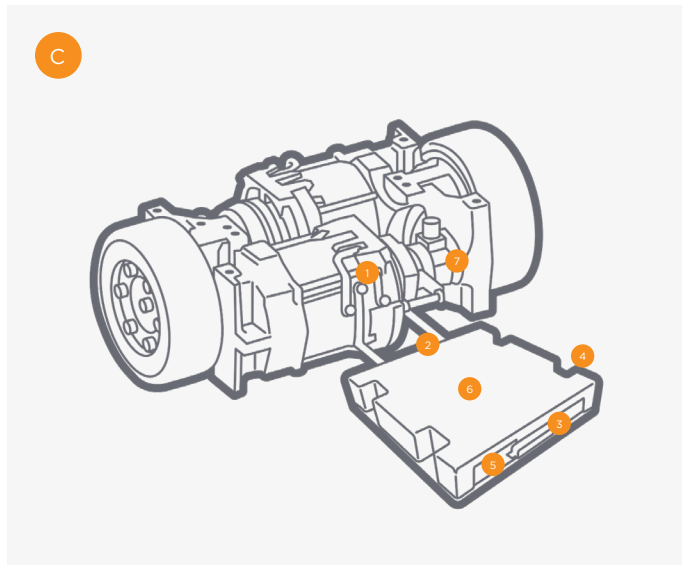
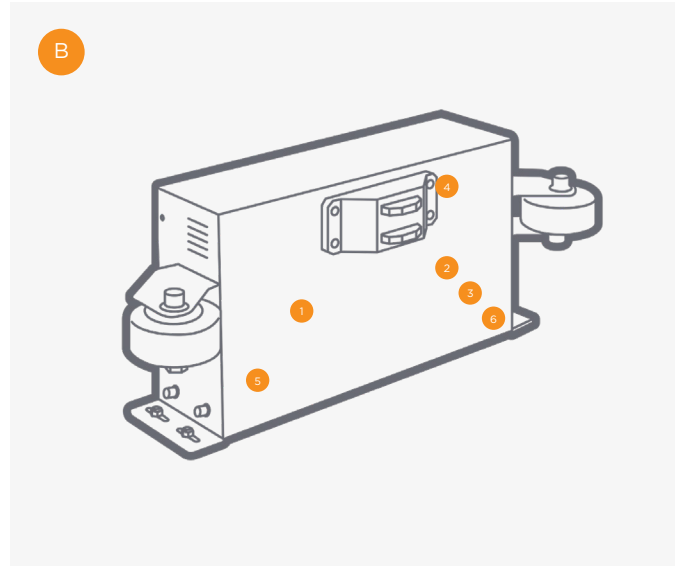
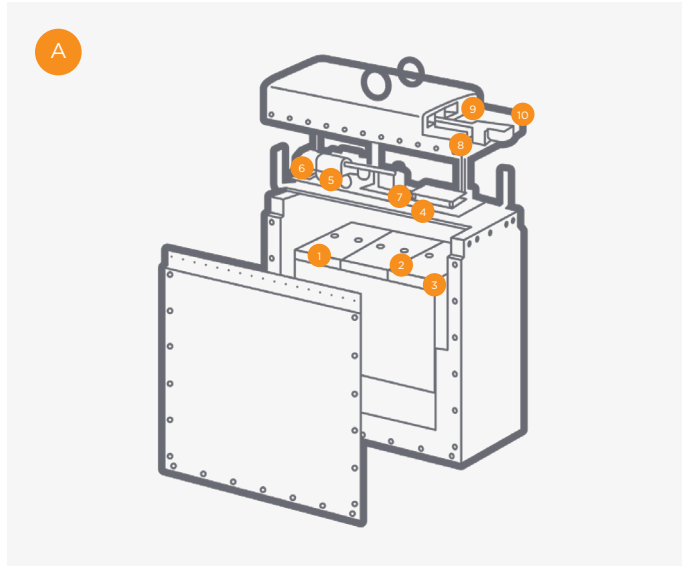

A. BATTERY AND BATTERY MANAGEMENT SYSTEM

- 1 [Cell interconnect](#)
- 2 [Connecting signals and data \(balancing\)](#)
- 3 [Connecting signals and data \(sensors\)](#)
- 4 [Connecting signals and data \(sensors\) \(cell controller to BMS communication\)](#)
- 5 [Connecting and disconnecting battery power/Contactors](#)
- 6 [Current sensing](#)
- 7 [Connecting signals and data \(contactor control\)](#)
- 8 [Connecting signals and data \(charger/vehicle\)](#)
- 9 [Power distribution](#)
- 10 [Manual/autonomous connection of charger](#)

B. CHARGING STATION

- 1 [Connect and disconnect charging power/Contactor](#)
- 2 [DC power distribution](#)
- 3 [Din rail terminal blocks for power distribution](#)
- 4 [Charging connector](#)
- 5 [EMI/RFI filtering](#)
- 6 [Connecting signals and data](#)

C. MOTOR AND DRIVE

- 1 [Motor connectivity \(motor\)](#)
- 2 [Motor connectivity \(drive\)](#)
- 3 [Power distribution](#)
- 4 [Braking resistors](#)
- 5 [Connecting signals and data](#)
- 6 [Internal controller connectivity](#)
- 7 [Motor feedback/position systems](#)

D. CONTROLS, SENSORS, AND VEHICLE WIRING

- 1 [In-device connectivity](#)
- 2 [Connecting power and signal](#)
- 3 [Data and ethernet connectivity](#)
- 4 [Push buttons and emergency stop switches](#)

AUTOMOTIVE CONNECTIVITY



TE offers high-reliability automotive connectors, housings, and contacts. TE's multiple contact point (MCP) connectors are designed for electronic and electrical power applications.

TE offers rugged circular plastic connectors (CPC); MCP sealed connectors; M8/M12 industrial sensors and actuator connectors; and the Dynamic compact, unsealed wire-to-board and wire-to-wire memory card connectors.

TE's automotive connectors include multiple contact points, making them more tolerant of high vibrational activity and environments. Rugged housing and high-retention force design support rugged connectivity.

BENEFITS:

- Design supports high current carrying capacity, reliability, and high vibration levels.
- Small form factors meet space restriction requirements.

MOTOR CONNECTORS

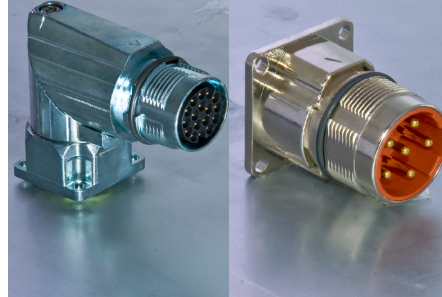

Adapting to even extremely harsh environments, TE's motor connectivity solutions help improve EMI/EMC performance. We offer wire-to-board and wire-to-wire connectors, industrial servo motor connectors, and ring terminals for a variety of wire sizes.

The Universal MATE-N-LOK wire-to-board and wire-to-wire connectors are available in a large portfolio of form factors and pin counts, providing proven and cost-effective power connection up to 9.5A. Our Dynamic 3000 Series and Complete Dynamic Series offer multiple contact points, robust housing, and a high retention force design that enables rugged connectivity. TE's Intercontec connectors offer 360-degree shielded connectors rated IP66/67 or higher for challenging motor applications. And our ring terminals are compact, cost-effective, and available in a variety of wire sizes.

BENEFITS:

- Large product portfolios provide for a wide usage and adaptability for a variety of applications.
- Ergonomic features increase connectivity speed and reduce assembly failures.

RELAYS AND CONTACTORS

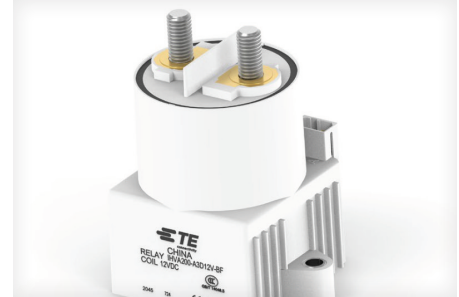

Reliably connecting and disconnecting battery power is critical to any automated warehouse operation. Battery poles must be disconnected when the battery is not in use, a toggle line between charging and operation is often needed, batteries must be disconnected under load, and contactors and relays may be included in the battery management as a separate unit.

TE offers many reliable relays and contactors, including high-voltage DC contactors up to 600A, such as IHVA150, IHV200, and Kilovac; solid state relays, such as the SSR3; and power PCB relays up to 50A, including the T92 Flyer.

BENEFITS:

- Different power levels on the contactors enable the use of high-capacity batteries.
- TE offers one of the largest portfolios of power relays on the market.
- Mechanics-free setup for the solid state relays increases switching lifetime and frequency.

SIGNAL AND DATA CONNECTORS

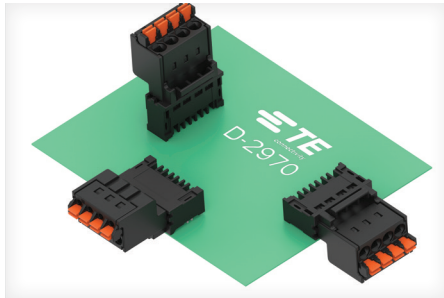

At TE, we know how important sensor, signal, and communication bus connections are between different boards — and how important it is that they are reliable and efficient. Modern signal and data connectors reduce the size of these products while simultaneously improving their reliability. TE's Dynamic Series memory card connectors offer unsealed wire-to-board and wire-to-wire solutions with options for fusing, voltage selections, switching, and filtering. These connectors integrate seamlessly into the power entry module.

BENEFITS:

- Different power levels on the contactors enable the use of high-capacity batteries.
- TE offers one of the largest portfolios of power relays on the market.
- Mechanics-free setup for solid state relays increases their switching lifetime and frequency.

BATTERY CHARGING CONNECTORS



Reliable power connectors reduce assembly efforts and help reduce safety hazards, and TE's products can help improve power distribution capabilities between the charger, battery, and drive system.

We offer the AMPOWER battery charging connector, the Dynamic wire-to-wire and wire-to-board memory card connector, the HVP sealed EV automotive connectors, and ring terminals for a wide range of wire sizes.

Our connectors offer multiple contact points to support high-vibration tolerance, and our large product portfolios serve a wide variety of uses and compact designs.

BENEFITS:

- Essentially no screw contact maintenance is needed.
- Large portfolio of product offerings meets a variety of needs and designs.

BRAKING RESISTORS



Braking resistors “burn” extra energy when a motor is used to brake, and TE makes them for a variety of environmental conditions and power levels. Offering sealed power resistors called aluminum-housed resistors, as well as unsealed power resistors called wire-wound tubular resistors, TE's products are compliant to support safer operation in your application.

Sealed resistors are excellent for remote mounting, away from temperature-sensitive electronics. The aluminum-house resistors offer different housing and mounting styles to support compact and ergonomic system design. They offer a power rating up to 2,000W continuous.

Unsealed power resistors offer high-power and high-temperature tolerance and power ratings up to 2,500W continuous. The wire-wound tubular resistors are very good for high, short-term overload capacity.

BENEFITS:

- Different housing and mounting styles support compact and ergonomic system design.
- Product compliances (e.g., IP54, UL94V, RoHS, and REACH) allow for safer operation in your application.

PUSH BUTTON SWITCHES



Push buttons and emergency switches are used for emergency stopping, either as battery main switches or a human-machine interface. TE offers a number of solutions that are compliant with safety regulations and standards, including power switches, push button switches, and emergency stop switches.

The battery disconnect switches, or power switches, meet high sealing requirements (IP670) and can be disconnected under load. The TE push button switches offer high reliability with a high-quality contact system, withstanding up to 50 million switching cycles under load. And the KISSLING switches and ALCOSWITCH - PBES switches offer high reliability with IP65 rating, mechanical life of more than 100,000 cycles, and operations and electrical life of more than 50,000 operations.

BENEFITS:

- Rugged, sealed designs meet high sealing requirements.
- Ergonomic products support application safety.

EMI FILTERS

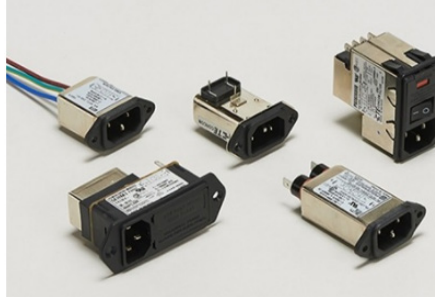

Choosing the right filtering solutions is paramount to protect your automated warehouse equipment. To limit EMI on the grid and battery, it is important to select the right EMI filters for both sides (AC and DC). TE provides a variety of EMI filters that comply with international EMC requirements.

Our multi-function inlet filters are power inlet filters effective up to 20A for small chargers. They include options for fusing, voltage, selections, switching, and filtering. Our 1-phase and 3-phase AC power line filters offer different form factors for compact setup. And our DC filters are medium- and multiple-stage high-performance DC power line filters that filter up to 125A.

BENEFITS:

- Pre-compliance EMI test results can be used to identify the optimum filter solution.
- EMI filters comply with international EMC requirements.

POWER DISTRIBUTION BLOCKS



Our compact and modular power distribution blocks distribute electrical circuits from a single input source to several devices in the branch circuit. TE power distribution blocks are easy to install, save space, and allow increased productivity as well as flexibility of use.

We offer three configurations in one product: single-pole splitter, multi-pole splitter, and grouping for solar. Our power distribution blocks are suitable for most recent solar installations with 1500V DC rating and up to 12 inputs.

Save up to 50% rail space compared to conventional distribution bars, thanks to our modular compact design. We also designed for easy identification with the pre-printed markers L1, L2, L3, N, PE, +, -.

You can reduce assembly time by 80% compared to conventional systems with our reduced wiring, inventories, hardware, and assembly costs. Our modular and touch proof concept significantly reduces the need for bus bars, isolators, fasteners, and protection screens.

BENEFITS:

- Reduce assembly time by 80% by avoiding the use of fastening and isolating components.
- Connect round or flat conductors and save up to 50% space compared to copper bars.

SENSORS

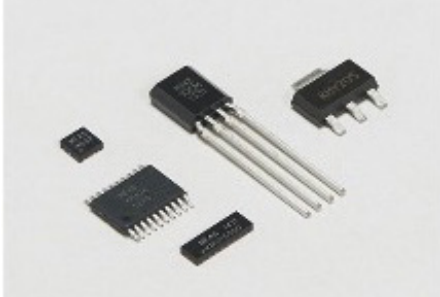

Sensors play an important role in motors and are a key component with which the motor controller communicates.

Our AMR magnetic position sensors are also popular for their high accuracy; up to 10-50 Qm with air gaps of 1mm-5mm. The AMR magnetic position sensors offer magnetoresistive (MR) sensors for contactless measurement and can be operated in temperatures up to 150°C.

BENEFITS:

- Designs are reliable and vibration-resistant.
- Highly accurate sensors are operable in high temperatures.

LET'S CONNECT

We make it easy to connect with our experts and are ready to provide all the support you need. Just call your local support number or visit te.com/industrial to chat with a product information specialist. Visit the [Warehouse Automation landing page](#) to learn more.

TECHNICAL SUPPORT

te.com/support-center

te.com

©2022 TE Connectivity. All Rights Reserved.

TE Connectivity, TE connectivity (logo) and Every Connection Counts are trademarks. All other logos, products and/or company names referred to herein might be trademarks of their respective owners.

The information given herein, including drawings, illustrations and schematics which are intended for illustration purposes only, is believed to be reliable. However, TE Connectivity makes no warranties as to its accuracy or completeness and disclaims any liability in connection with its use. TE Connectivity's obligations shall only be as set forth in TE Connectivity's Standard Terms and Conditions of Sale for this product and in no case will TE Connectivity be liable for any incidental, indirect or consequential damages arising out of the sale, resale, use or misuse of the product. Users of TE Connectivity products should make their own evaluation to determine the suitability of each such product for the specific application.

000000XX 02/22 Original

BROCHURE

TE Connectivity
1050 Westlakes Drive
Berwyn, PA 19312
Tel +1 610 893 9800

