

Reflowable Thermal Protection (RTP) Device for Automotive HVAC and Cooling Fan Systems

PowerFET Failure in Harsh Environments

In the harsh automotive environment, power Field Effect Transistors (powerFETs) are routinely subjected to extreme temperature variations and thermo-mechanical stress. Intermittent shorts, cold operating environments, high arcing or noisy short circuits, as well as inductive loads and multiple short circuits can, over time, fatigue the device and cause it to fail in open, short or resistive mode.

Although powerFETs are increasingly robust, they are prone to failures which can occur very quickly if their ratings are exceeded. If the maximum operating voltage of a powerFET is exceeded, it goes into avalanche breakdown. If the energy contained in the transient overvoltage is above the rated avalanche energy level, the device will fail; causing a destructive thermal event that may result in smoking, flame or desoldering.

Automotive powerFETs have been shown to be more prone to fatigue and failure than devices that are installed in less demanding applications. When comparing powerFET failure rates over time, devices used in harsh environments, such as automotive applications, exhibit greater ppm failure rates. After five years in the field the difference can be more than a factor of ten.

Although a powerFET may pass initial testing, it has been demonstrated that, given certain conditions, random weak points in the device can result in field failure. Even in situations where the powerFET is functioning within specified operating conditions, random and unpredictable resistive shorts at varying resistance values have been reported.

The resistive mode failure is of particular concern, not only for the powerFET but for the Printed Circuit Board (PCB). As little as 10W may generate a localized hot spot of more than 180°C, well above the typical PCB's glass transition temperature of 135°C, damaging the board's epoxy structure and leading to a thermal event.

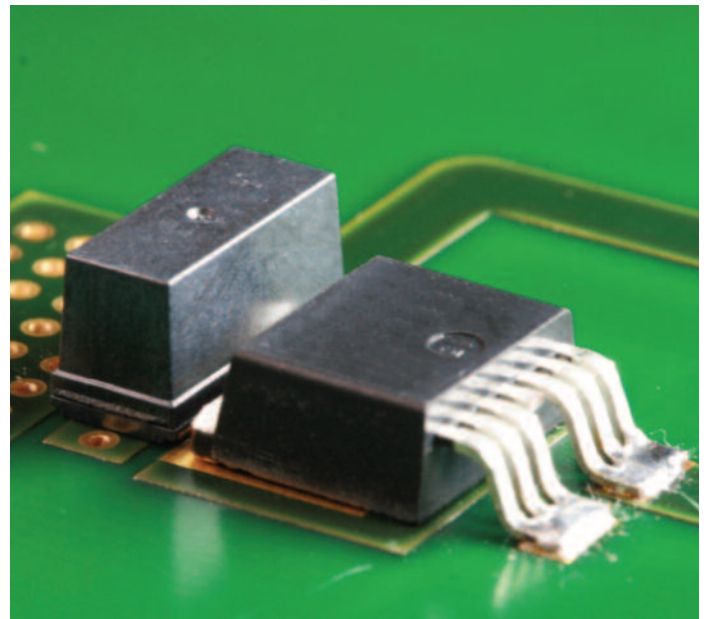

Figure 1 describes a scenario where a failed powerFET may not generate a hard short overcurrent condition but rather a resistive short, producing unsafe temperatures through I^2R heating. In this case the resulting current may not be high enough to blow a standard fuse and stop thermal runaway on the PCB.

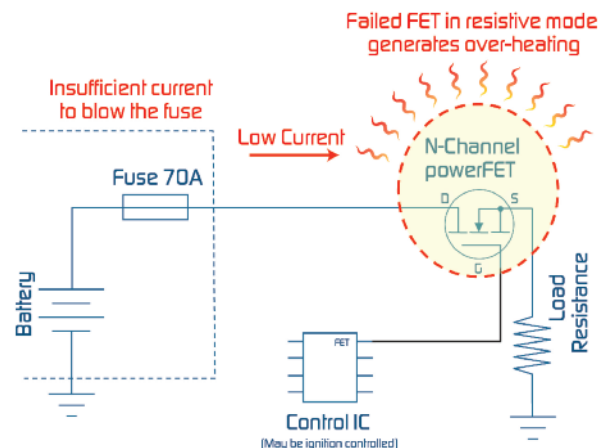

Figure 1. PowerFET failure in resistive mode can lead to unsafe overtemperature conditions.

A New Thermal Protection Solution

TE's Reflowable Thermal Protection (RTP) device is a robust, reliable surface mount thermal protector that helps prevent thermal damage caused by failed power electronics. The secondary thermal protection device can be used to replace redundant powerFETs, relays and heavy heat sinks typically used in automotive designs.

If a power component failure or a board defect generates unsafe overtemperature conditions the RTP200 device, which opens at 200°C (a value above normal operating

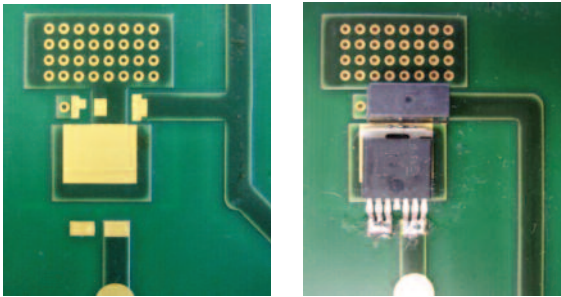

Figure 2. RTP device and powerFET are installed in close contact on the PCB, sharing some pads for better thermal conductivity.

temperatures but below Pb-free solder reflow temperatures), will interrupt the current and help prevent a thermal runaway condition that may lead to critical damage.

As shown in Figures 2 and 3, when the RTP device is placed in series on the power line in close proximity to the FET, it tracks the FET temperature and opens the circuit before a slow thermal runaway condition can generate a destructive thermal condition on the board.

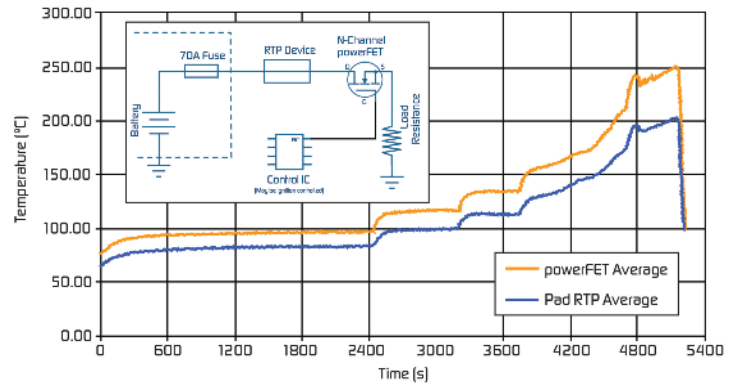

Figure 3. In a slow thermal runaway condition, the RTP200 device tracks the powerFET temperature until it opens the circuit at 200°C.

Protecting Cooling Fan Modules from Damage Caused by Thermal Runaway

Cooling fan modules (CFMs) are an essential element of the vehicle's HVAC and engine cooling systems, helping to cool the engine and prevent potential overheating under specific conditions, such as hot weather and steep hill driving. Figure 4 shows placement of the RTP device in a CFM application.

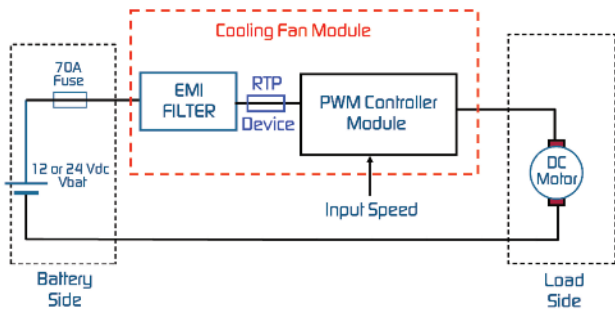

Figure 4. Block diagram of RTP device placement in CFM application.

CFM modules are typically placed under the hood and they experience more extreme temperature variations than those found in the passenger compartment. This thermal stress can accelerate fatigue of the powerFET and lead to early failure. Under-the-hood components may also be exposed

to "fluid attacks" leading to corrosion and localized hot spots on the PCB.

Typically, CFMs do not include a micro-controller which, under certain conditions, could be used for onboard diagnostics and automatic initiation of the turn-off signal to the powerFET. As a result, a software approach to preventing powerFET failure is not available, and secondary protection is needed so that thermal runaway does not cause a dangerous thermal event.

In some design configurations the powerFET may be connected directly to the battery (+Vbat). In this case, even if the ignition is turned off, power may still be supplied to the device. In the event of a failure leading to unsafe temperatures, power from the engine would not power-off the circuit, which would continue to see the thermal event.

In most automotive cooling fan applications, powerFETs are used in the control modules to switch power to the fan motor on and off as needed. There are two typical motor configurations used in CFM applications: brush and brushless. Figures 5 and 6 illustrate the two configurations and the

associated electronics, and define the sensitive area where power component failures could generate unsafe thermal runaway conditions.

In these applications, the RTP device helps prevent thermal runaway from generating a destructive thermal event. The device is placed in the sensitive area of the application and will open the circuit as soon as it sees a temperature above its opening temperature.

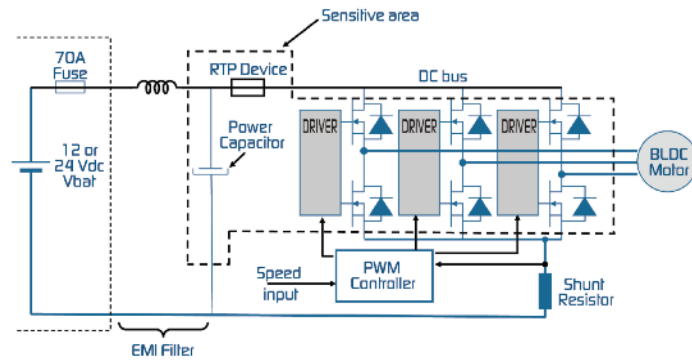

Figure 5. Three-Phase Brushless DC Motor Configuration.

Although this application note focuses on powerFETs, the RTP device also helps protect against thermal-runaway damage caused by capacitors, ICs, resistors and other power components that can crack and fail, or from the effects of any type of corrosion-induced heating. As shown in Figures 5 and 6, the capacitor in the sensitive area could be another potential source of local overheating.

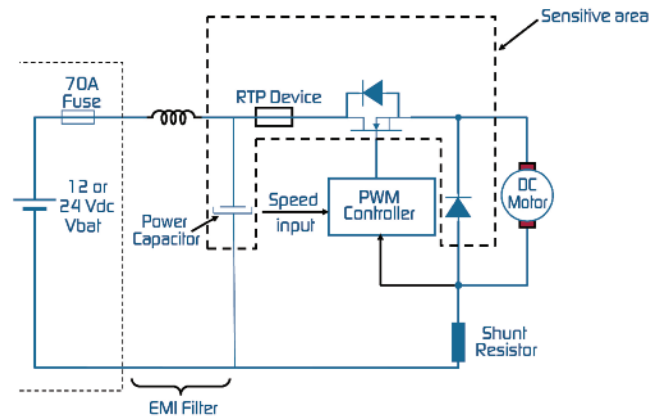

Figure 6. Brush DC Motor Configuration.

Mounting Recommendations

Thermal conductivity between the RTP device and the heat source is highly dependent on layout of the PCB, heat sink structures, and relative placement and design of co-located components.

When used on an FR4 PCB, intimate thermal contact with the potential heat source is critical in order to achieve the desired protection performance. Here the P_{TH} pin of the RTP200 device must share a copper mounting pad with the primary thermal pin or heat sink of the powerFET or protected component. Board layout recommendations for optimal thermal coupling are shown in Figure 7 and are as follows:

- RTP device's P_{TH} pad must be placed as close to the powerFET heat sink as practical
- Connect the P_{TH} pad to the powerFET heat sink with as thick and wide a copper trace as practical
- Additional copper layers should not be placed directly underneath the P_{TH} pad, and if possible, pull additional copper layers away from the RTP device's P_{TH} pad. These additional copper layers work to pull heat away from the RTP and decrease its thermal sensitivity.
- Pull top layer "cooling" traces as far away from RTP device's P_{TH} pad as practical

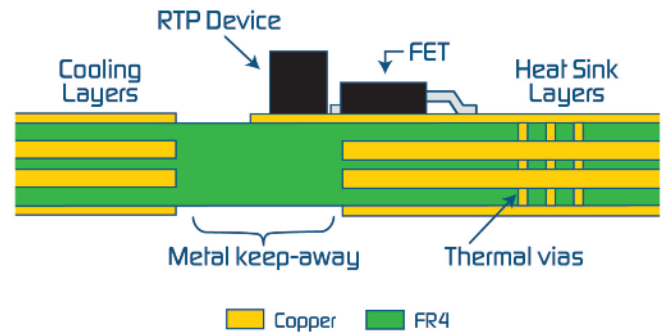

Figure 7. Board layout recommendations for FR4 installation.

In an Insulated Metal Substrate (IMS) layout design, flexibility is considerably greater, as thermal propagation is improved. In high-power, high-density designs, the RTP device can be placed up to 10cm from the power component, as shown in Figure 8.

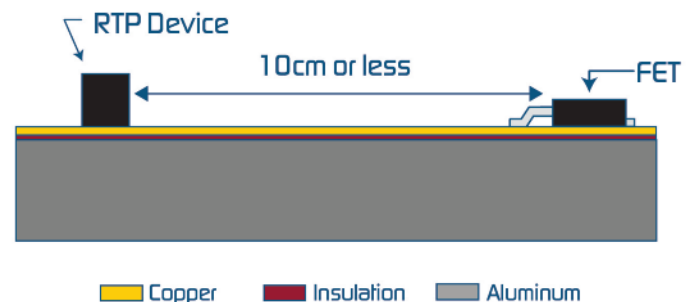

Figure 8. Board layout recommendations for IMS substrate.

Figure 9 shows the performance of the RTP device on an IMS structure with placement at 10cm from the powerFET. The thermal gradient between the failed powerFET and the RTP device is approximately 40°C, even with a 10cm distance between the two components.

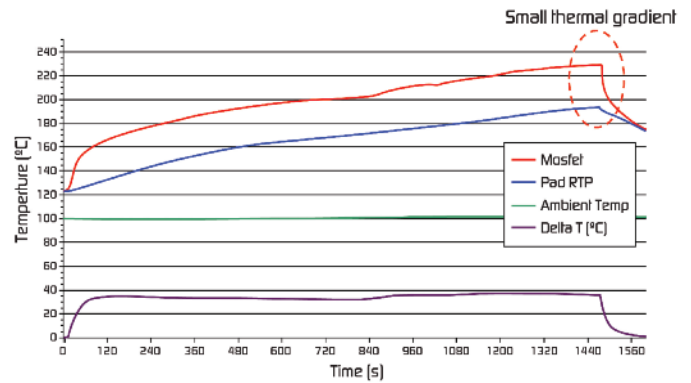

Figure 9. RTP device performance on IMS structure.

A Robust, Reflowable Thermal Protection Solution

The RTP device helps meet the reliability requirements of automotive power electronics systems such as cooling fan applications, as well as ABS, power steering, PTC heaters, etc. The RTP200 device's 200°C open temperature helps prevent false activations and improves system reliability since it is a value above the normal operating window of most normally functioning electronics, but below the melting point of typical lead-free solders. As a result, the RTP200 device will not open if surrounding components are operating in their target temperature range, but it will open before a component de-solders and creates the potential risk of additional short circuits.

To allow it to open at 200°C in the field, the RTP device utilizes a one-time electronic arming procedure to become thermally sensitive. Before arming, it can withstand three Pb-free solder reflow steps without opening. Timing of

electronic arming is user-determined, and can be implemented to occur automatically at system power up or during system testing.

The device's thermal sensitivity is beneficial since, in some cases, failed power components may not generate a dead short circuit overcurrent condition, but instead may create a resistive short that cannot be opened by a traditional fuse. This type of event may actually reduce load current, but can still result in unsafe thermal runaway conditions. The RTP200 device helps prevent damage caused by both dead short circuit and resistive short circuit conditions.

The information provided in this application note describes the RTP200R120SA device. Further product extensions, including a 0.6mOhm RTP device, will continue to enhance TE's product offering of circuit protection solutions.

TE Circuit Protection

308 Constitution Drive
Menlo Park, CA USA 94025-1164
Tel : (800) 227-7040, (650) 361-6900
Fax : (650) 361-4600

www.circuitprotection.com
www.circuitprotection.com.hk (Chinese)
www.te.com/japan/bu/circuitprotection (Japanese)

TE Connectivity, TE connectivity (Logo) and TE (logo) are trademarks of the TE Connectivity Ltd. family of companies. Other logos, product and company names mentioned herein may be trademarks of their respective owners. All information, including illustrations, is believed to be accurate and reliable. However, users should independently evaluate the suitability of each product for their application. Tyco Electronics Corporation and/or its Affiliates in the TE Connectivity Ltd. family of companies ("TE") makes no warranties as to the accuracy or completeness of the information, and disclaims any liability regarding its use. TE's only obligations are those in the TE Standard Terms and Conditions of Sale and in no case will TE be liable for any incidental, indirect, or consequential damages arising from the sale, resale, use, or misuse of the product. Specifications are subject to change without notice. In addition, TE reserves the right to make changes without notification to Buyer — to materials or processing that do not affect compliance with any applicable specification.

©2011 Tyco Electronics Corporation, a TE Connectivity Ltd. company. All rights reserved. RCP0099E.1210

