

## V-Series Inclinometer

# Instruction Manual

## Single and Dual Axis Inclinometer

### V-Series



Version 1.1



## V-Series Inclinometer

### Table of Contents

1	Introduction .....	3
2	Notice .....	3
3	History .....	3
4	General of the inclinometer system .....	4
4.1	Description of the liquid/conductive measurement principle .....	4
4.2	Ordering information .....	5
4.3	Electrical Connection .....	6
4.4	Cable/Connector Assembly (optional) .....	6
5	Dimensions / Mounting/ Electrical Connections .....	7
5.1	Dimensions [mm].....	7
5.2	Mounting Instruction .....	8
5.3	Installation.....	8
5.4	Measurement Direction .....	8
5.5	Electrical Connections .....	9
5.5.1	Pinning single axis unit with voltage output signal: NS-5/V, NS-15/V, NS-45/V .....	9
5.5.2	Pinning single axis unit with current output signal: NS-5/VI, NS-15/VI, NS-45/VI.....	11
5.5.3	Pinning dual axis unit with voltage output signal: NS-5/V2, NS-15/V2, NS-45/V2.....	12
5.5.4	Pinning dual axis unit with current output signal: NS-5/V2I, NS-15/V2I, NS-45/V2I .....	14
6	Packaging for Delivery .....	15
7	Additional Information .....	15

## V-Series Inclinometer

### 1 Introduction

Thank you for purchase of a V-Series inclinometer from TE Connectivity Sensors. This manual offers information on the proper installation and operation.

### 2 Notice



Please observe all proper safety rules and regulations for electrical devices when installing this inclinometer. In addition, the following recommendations are made.

1. Do not apply power to the inclinometer during installation.
2. Avoid applying any mechanical pressure or stress to the housing.
3. Do not operate an inclinometer beyond the maximum angular sensing range or threshold. Irreparable damage may occur.
4. Do not exceed the maximum fastening torque for the mounting screws, as the base plate may become warped and/or irreparably damaged.
5. Use detergents free of alcohol or acid for cleaning of the housing.
6. Avoid direct solar radiation.
7. Hand tightens mating connector. DO NOT use pliers as damage may occur.
8. Should the inclinometer fail to operate properly, consult this manual for possible solution. Do not attempt to open the inclinometer, as damage may occur. For other troubleshooting measures, please contact our customer service team.

### 3 History

Version	Date	Treatment	Author
1.0	30.Nov.2011	First Draft	M.Zürn
1.1	13.Mar.2017	Add layout	M.Zürn

## V-Series Inclinometer

### 4 General of the inclinometer system

#### 4.1 Description of the liquid/conductive measurement principle

Platinum electrodes are deposited in pairs on the base of the sensor's cell parallel to the sensitive axis. The chamber is partially filled with an electrolytic liquid. When an alternating voltage is passed between two electrodes, the electric current will create a dispersed field. By tilting the sensor and thereby reducing the level of liquid, it is possible to confine this stray field. Because of the constant, specific conductivity of the electrolytes a variance of resistance is formed in relation to the liquid level. A basic differential principle will yield an angle of inclination from the polarity signs.

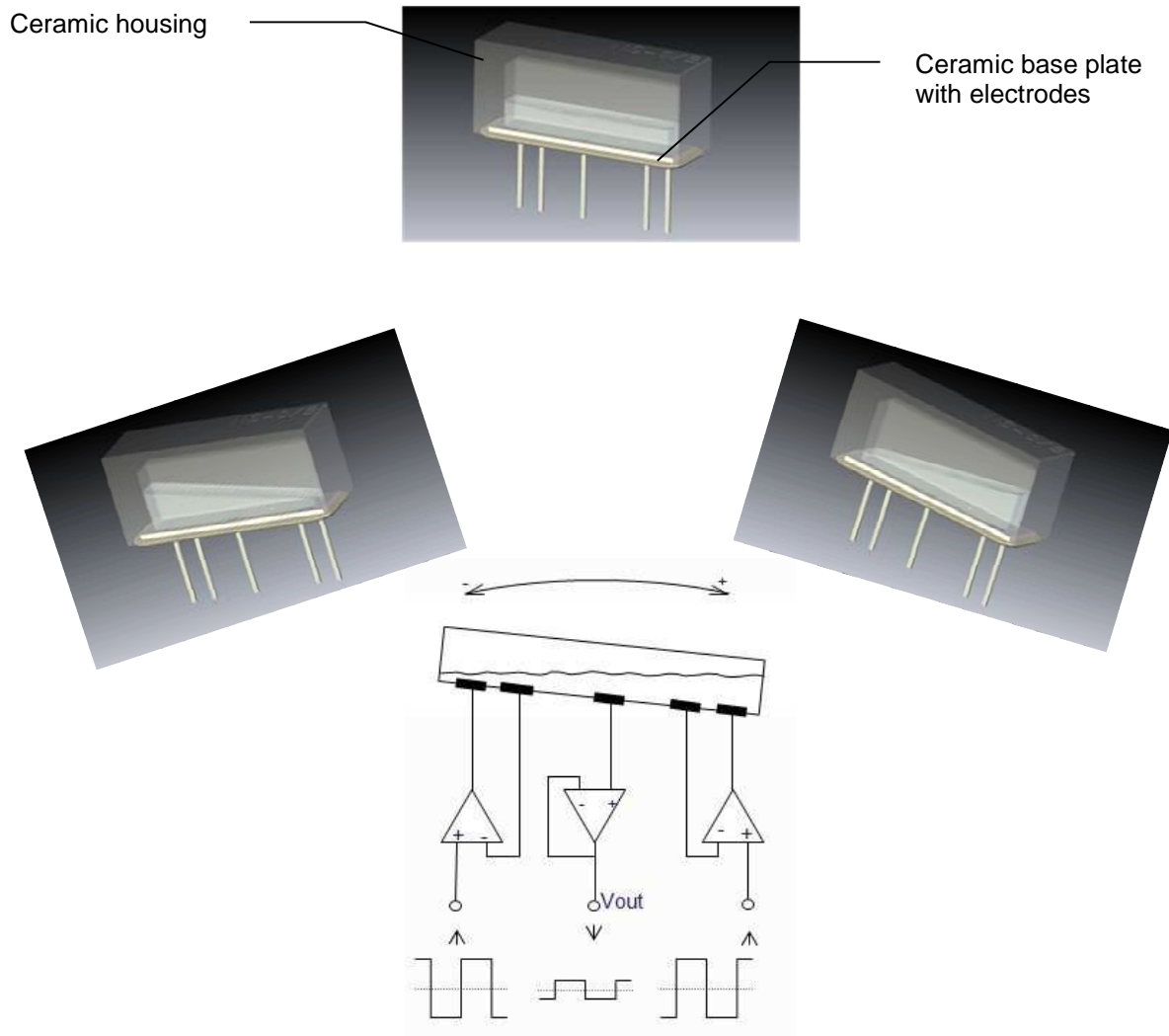

## V-Series Inclinometer

### 4.2 Ordering information

Measurement Specialties offers single and dual axis inclinometers of the V-series in the three different measurement ranges +/- 5°, +/- 15° and +/-45° with voltage or current output signals.

PART NUMBERING	UNIT	SHORT DESCRIPTION
<b>Single axis unit</b>		
G-NSV-001	NS- 5/V	single axis,range +/- 5°;Vcc 1 2...24VDC,output V
G-NSVI-001	NS- 5/VI	single axis,range +/- 5°;Vcc 1 2...24VDC,output I
G-NSV-002	NS-15/V	single axis,range +/-15°;Vcc 1 2...24VDC,output V
G-NSVI-003	NS-15/VI	single axis,range +/-15°;Vcc 12 ...24VDC,output I
G-NSV-005	NS-45/V	single axis,range +/-45°;Vcc 1 2...24VDC,output V
G-NSVI-006	NS-45/VI	single axis,range +/-45°;Vcc 12 ...24VDC,output I
<b>Dual axis unit</b>		
G-NSV2-001	NS- 5/V2	dual axis,range +/- 5°;Vcc 12...24VDC,output V
G-NSV2I-001	NS- 5/V2I	dual axis,range +/- 5°;Vcc 12 ...24VDC,output I
G-NSV2-003	NS-15/V2	dual axis,range +/-15°;Vcc 12...24 VDC,output V
G-NSV2I-003	NS-15/V2I	dual axis,range +/-15°;Vcc 12... 24VDC,output I
G-NSV2-006	NS-45/V2	dual axis,range +/-45°;Vcc 12...24 VDC,output V
G-NSV2I-006	NS-45/V2I	dual axis,range +/-45°;Vcc 12... 24VDC,output I
<b>Accessories</b>		
G-NSMIS-001	Connection	Connector,straight, Submin. 712-series
G-NSMIS-015	Connection	Connector, angle 90°, Subm in. 712-series
G-NSMIS-002	Connection	2 m cable, straight connector Submin. 702-series
G-NSMIS-003	Connection	2 m cable, angle 90° connector Submin .702-series

Other lengths of cable on request.

## V-Series Inclinometer

### 4.3 Electrical Connection

- 7 pin male socket. Manufacturer = 'Binder – Connectors', type 712, M9 x 0.5

### 4.4 Cable/Connector Assembly (optional)

Type of cable: LiYCY 6 x 0.14mm<sup>2</sup>  
 Conductor resistance: 131 Ohm/km  
 Capacity: 90pF/m at 1kHz  
 Length: 2m (further lengths on request)  
 Connector: 712 (M9 x 0.5)

- Straight connector, order-no.: G-NSMIS-002
- Angle (90°) connector, order-no.: G-NSMIS-003

- **Connector only (optional)**

- Straight connector, order-no.: G-NSMIS-001

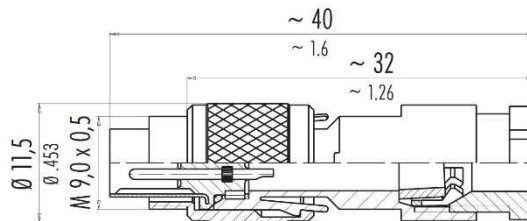

Fig. 4.4.1 Connector drawing , straight

- Angle 90° connector, order-no.: G-NSMIS-015

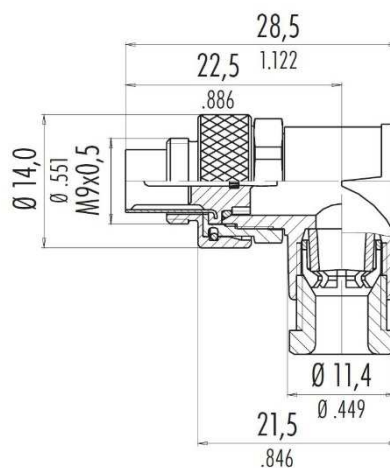

Fig. 4.4.2 Connector drawing , angle 90°

V-Series Inclinometer

5 Dimensions / Mounting/ Electrical Connections

5.1 Dimensions [mm]

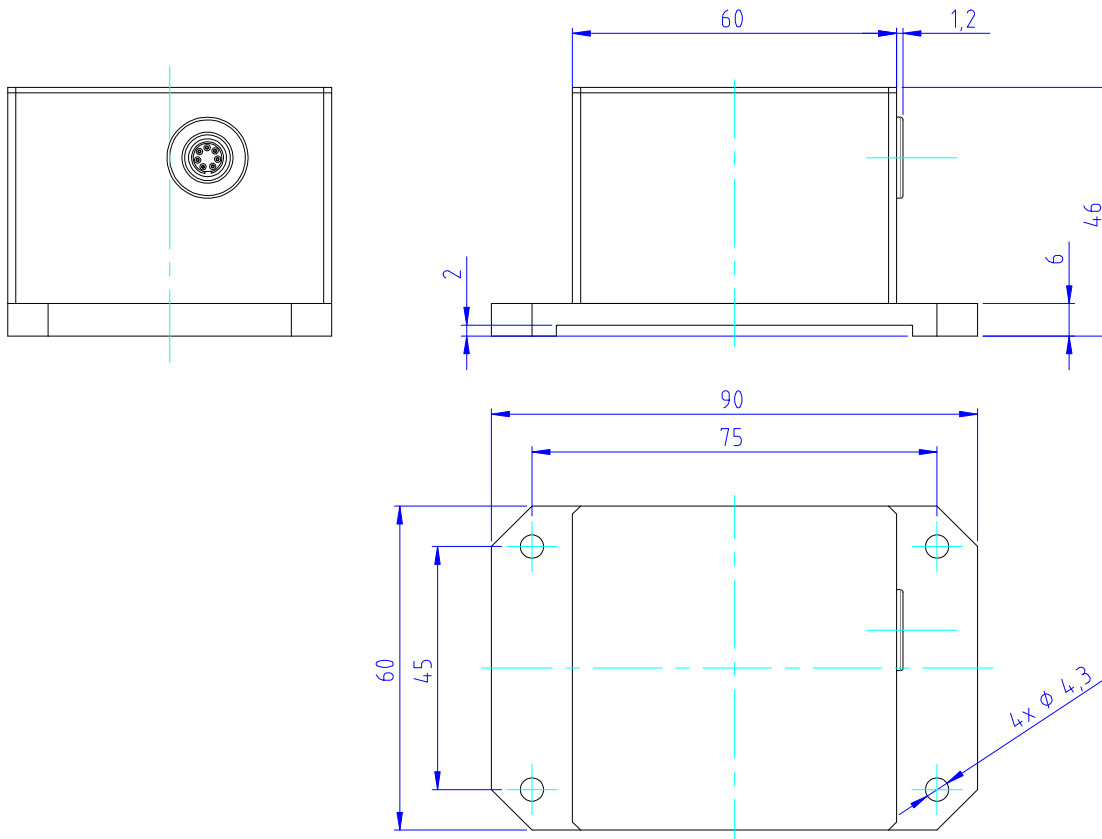

Fig. 5.1.1 View of the inclinometer housing and connector

## V-Series Inclinometer

### 5.2 Mounting Instruction

The inclinometer is designed for horizontal mounting, meaning the base plate of the inclinometer with the four mounting holes needs to be placed on the horizontal plane of the object to be measured. The mounting surface must be smooth and free of dust and grease. Fasten inclinometer to the surface to be measured using three #M4 screws, and torque to a maximum of 10 Nm (do not exceed!!).

### 5.3 Installation

Prior to installation, please check for all connection and mounting instructions to be complied with. Please also observe the general rules and regulations on low voltage technical devices.

Avoid shock and vibration during measurement, as these could adulterate the measurement results. Inclination sensors that base on a fluidic measurement principle are optimal for static measurements and suitable to only a limited extent of dynamic measurement.

### 5.4 Measurement Direction

Tilt angle measurements are made in the 'X' and 'Y' axis' (longitudinal and lateral respectively), with the reference being the horizontal plane.

For **single axis** units the longitudinal axis 'X' is valid only.

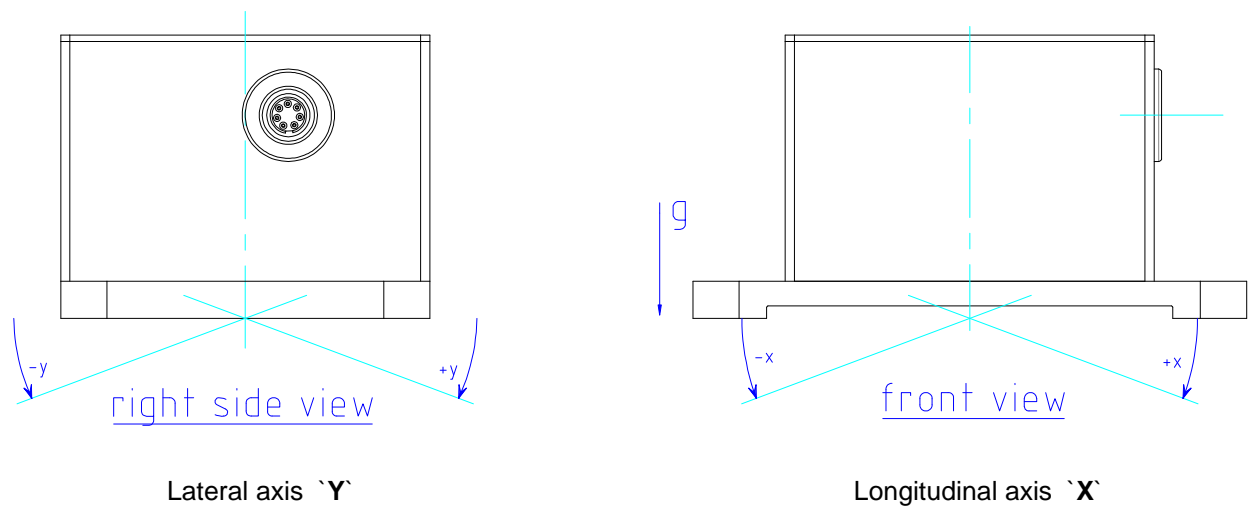

Fig. 5.4.1 X and Y axis identification



## V-Series Inclinometer

### 5.5 Electrical Connections

#### 5.5.1 Pinning single axis unit with voltage output signal: NS-5/V, NS-15/V, NS-45/V

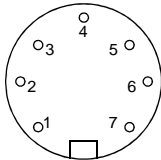

Pin	Name	Description	Type	Color schema(1)
1	Vcc	Positive power supply +12...+24VDC	Supply, Input	white
2	GND	Ground, negative supply voltage	Supply, Input	brown
3	Earth	Protection conductor	Supply, Input	green
4	GNDx	Ground for output voltage signal X axis	Output	yellow
5	n.c.	n.c.	-	grey
6	Out Vx	Output voltage signal X axis	Output	pink
7	n.c.	n.c.	-	blue

(1) by using a Measurement Specialties cable

#### Output connecting possibility 1

Pin 6 output voltage signal Vx x-axis



Output signal – 2V (- 5°) up to +2V (+ 5°)  
 Output signal – 2V (-15°) up to +2V (+15°)  
 Output signal – 2V (-45°) up to +2V (+45°)

Pin 4 GNDx analogue ground x-axis

Typical curve of voltage output signal +/-2 V in reference to signal GNDx of an inclinometer NS-5/V.

**Notice !** The signal ground GNDx has **not** the potential like the power ground GND.

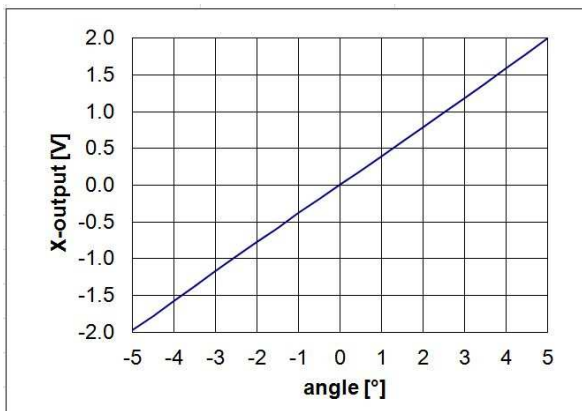

Fig. 5.5.1.1 X-output [V] vs. angle [°]

## V-Series Inclinometer

### Output connecting possibility 2

Pin 6 output voltage signal  $V_x$  x-axis



Output signal + 0,5V (- 5°) up to + 4,5V (+ 5°)

Output signal + 0,5V (-15°) up to + 4,5V (+15°)

Output signal + 0.5V (-45°) up to + 4,5V (+45°)

Pin 2 GND supply ground

Typical curve of voltage output signal +0.5...+4.5V in reference to power ground signal GND of an inclinometer NS-5/V.

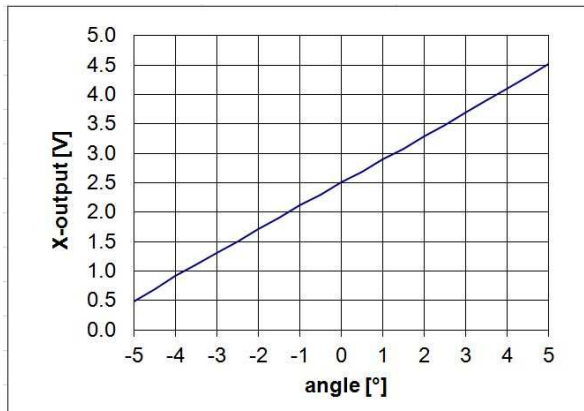
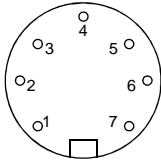

Fig. 5.5.1.2 X-output [V] vs. angle [°]

## V-Series Inclinometer

### 5.5.2 Pinning single axis unit with current output signal: NS-5/VI, NS-15/VI, NS-45/VI



Pin	Name	Description	Type	Color schema(1)
1	Vcc	Positive power supply +12...+24VDC	Supply, Input	white
2	GND	Ground, negative supply voltage	Supply, Input	brown
3	Earth	Protection conductor	Supply, Input	green
4	GNDx	Ground for output current signal X axis	Output	yellow
5	n.c.	n.c.	-	grey
6	Out Ix	Output current signal X axis	Output	pink
7	n.c.	n.c.	-	blue

(1) by using a Measurement Specialties cable

Typical curve of current x output signal 4...20mA in reference to the signal ground GNDx of an inclinometer NS-5/VI

**Notice!** In this case signal ground GNDx and GNDy have the same potential like power ground GND. Measurement range -x (20mA) ... 0° (~12mA) ... +x (4 mA)

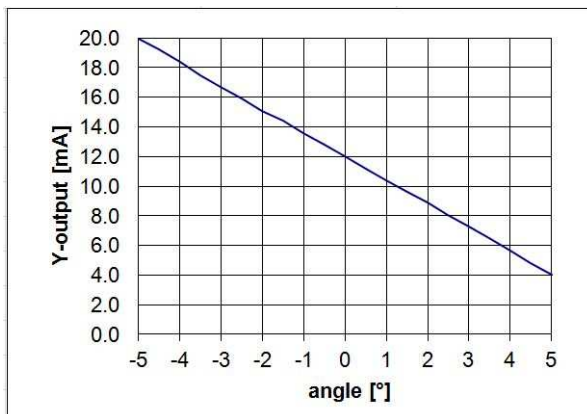
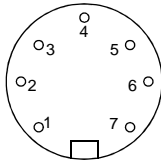

Fig. 5.5.2.1 X-output [mA] vs. angle [°]

## V-Series Inclinometer

### 5.5.3 Pinning dual axis unit with voltage output signal: NS-5/V2, NS-15/V2, NS-45/V2



Pin	Name	Description	Type	Color schema(1)
1	Vcc	Positive power supply +12...+24VDC	Supply, Input	white
2	GND	Ground, negative supply voltage	Supply, Input	brown
3	Earth	Protection conductor	Supply, Input	green
4	GNDx	Ground for output voltage signal X axis	Output	yellow
5	GNDy	Ground for output voltage signal Y axis	Output	grey
6	Out Vx	Output voltage signal X axis	Output	pink
7	Out Vy	Output voltage signal Y axis	Output	blue

(1) by using a Measurement Specialties cable

#### Output connecting possibility 1

Pin 6,7 output voltage signal Vx x-axis, Vy y-axis

Output signal – 2V (- 5°) up to +2V (+ 5°)  
 Output signal – 2V (-15°) up to +2V (+15°)  
 Output signal – 2V (-45°) up to +2V (+45°)

Pin 4,5 GNDx,y analogue ground x,y-axis

Typical curve of voltage output signal +/-2 V in reference to signal GNDx,y of an inclinometer NS-5/V2.  
**Notice !** The signal ground GNDx and GNDy have **not** the potential like the power ground GND.

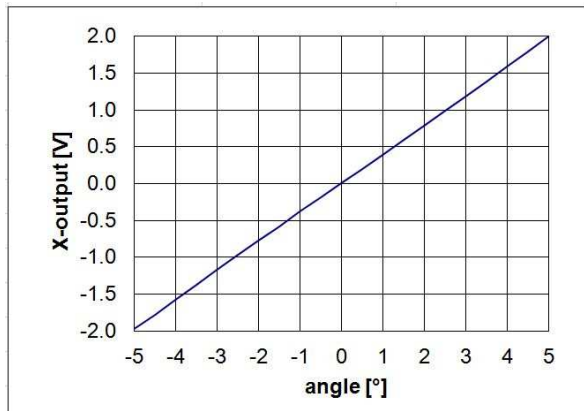

Fig. 5.5.3.1 X-output [V] vs. angle [°]

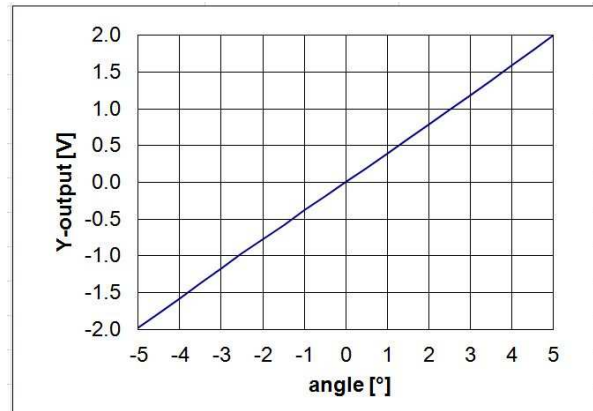

Fig. 5.5.3.2 Y-output [V] vs. angle [°]

## V-Series Inclinometer

### Output connecting possibility 2

Pin 6,7 output voltage signal Vx x-axis, Vy y-axis



Output signal + 0,5V ( - 5°) up to + 4,5 V ( + 5°)

Output signal + 0,5V (-15°) up to + 4,5V (+15°)

Output signal + 0.5V (-45°) up to + 4,5V (+45°)

Pin 2 GND supply ground

Typical curve of voltage output signal 0.5...4.5V in reference to power GND of an inclinometer NS-5/V2.

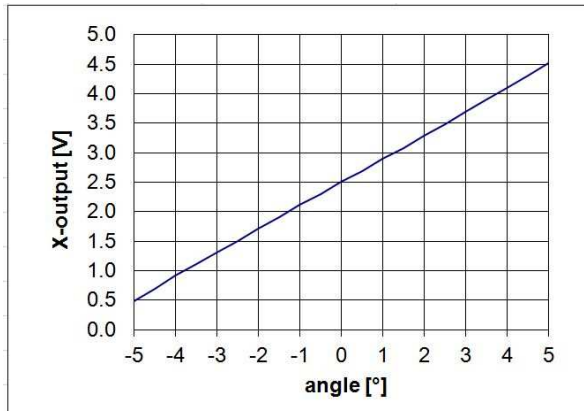

Fig. 5.5.3.3 X-output [V] vs. angle [°]

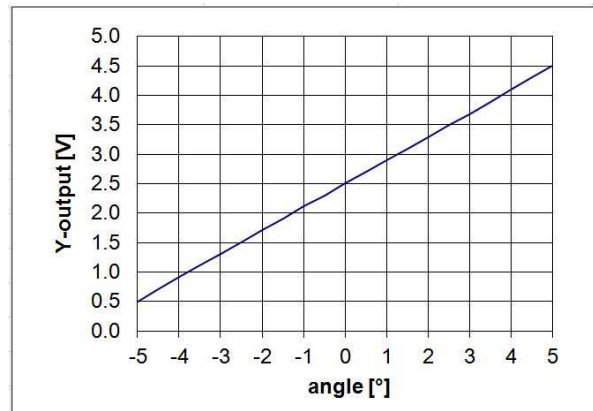
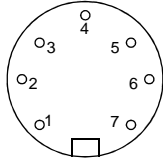

Fig. 5.5.3.4 Y-output [V] vs. angle [°]

## V-Series Inclinometer

### 5.5.4 Pinning dual axis unit with current output signal: NS-5/V2I, NS-15/V2I, NS-45/V2I



Pin	Name	Description	Type	Color schema(1)
1	Vcc	Positive power supply +12...+24VDC	Supply, Input	white
2	GND	Ground, negative supply voltage	Supply, Input	brown
3	Earth	Protection conductor	Supply, Input	green
4	GNDx	Ground for output current signal X axis	Output	yellow
5	GNDy	Ground for output current signal Y axis	Output	grey
6	Out Ix	Output current signal X axis	Output	pink
7	Out Iy	Output current signal Y axis	Output	blue

(1) by using a Measurement Specialties cable

Typical curve of current output signal 4...20mA in reference to signal ground GNDx, GNDy of an inclinometer NS-5/V2I

**Notice!** In this case signal ground GNDx and GNDy have the same potential like power ground GND. Measurement range  $-x, -y$  (20mA) ...  $0^\circ$  (~12mA) ...  $+x, +y$  (4 mA)

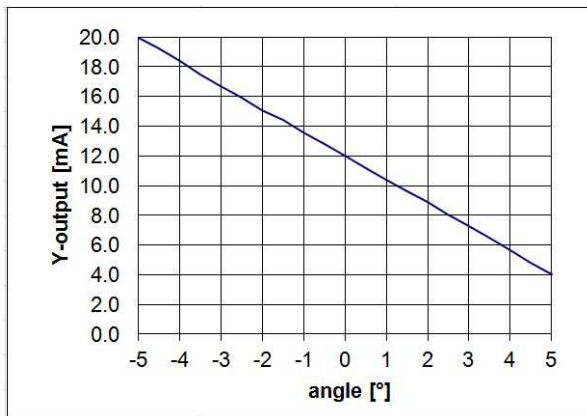

Fig. 5.5.4.1 X-output [mA] vs. angle [°]

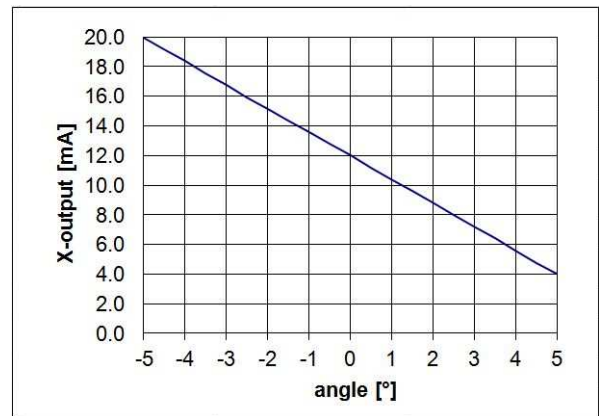

Fig. 5.5.4.2 Y-output [mA] vs. angle [°]



## V-Series Inclinometer

### 6 Packaging for Delivery

Safe single package “Blitz Versandbox”, company “Ratioform”, type CVB (150x110x67 mm, for one piece) type will used for the delivery of the product.

### 7 Additional Information

#### ORDERING INFORMATION

NORTH AMERICA	EUROPE	ASIA
<p>TE Connectivity Sensors, Inc.            1000 Lucas Way            Hampton, VA 23666            United States            Phone: +1-800-745-8008            Fax: +1-757-766-4297            Email: <a href="mailto:customercare.hmpt@te.com">customercare.hmpt@te.com</a>            Web: <a href="http://www.te.com">www.te.com</a></p>	<p>TE Connectivity Sensors            Germany GmbH            Hauert 13            D-44227 Dortmund            Germany            Phone: +49-(0)231-9740-0            Fax: +49-(0)231-9740-200            Email: <a href="mailto:customercare.dtmd@te.com">customercare.dtmd@te.com</a>            Web: <a href="http://www.te.com">www.te.com</a></p>	<p>TE Connectivity Sensors China Ltd.            No. 26, Langshan Road            High-tech Park (North)            Nanshan District, Shenzhen 518057            China            Phone: +86-755-33305088            Fax: +86-755-33305099            Email: <a href="mailto:customercare.shzn@te.com">customercare.shzn@te.com</a>            Web: <a href="http://www.te.com">www.te.com</a></p>

The information in this sheet has been carefully reviewed and is believed to be accurate; however, no responsibility is assumed for inaccuracies. Furthermore, this information does not convey to the purchaser of such devices any license under the patent rights to the manufacturer. TE reserves the right to make changes without further notice to any product herein. TE makes no warranty, representation or guarantee regarding the suitability of its product for any particular purpose, nor does TE assume any liability arising out of the application or use of any product or circuit and specifically disclaims any and all liability, including without limitation consequential or incidental damages. Typical parameters can and do vary in different applications. All operating parameters must be validated for each customer application by customer’s technical experts. TE does not convey any license under its patent rights nor the rights of others.