

## V-SERIES INCLINOMETER

### SPECIFICATIONS

- Single or dual axis inclinometer
- Measurement range  $\pm 5^\circ$ ,  $\pm 15^\circ$  or  $\pm 45^\circ$
- Analogue voltage or current output signal
- AL-housing IP 65

### FEATURES

- Single or dual axis inclinometer
- Analogue voltage or current output signal
- Easy to mounted
- High resolution
- Protection class IP 65
- Rugged M9 7 pins connector
- Robust AL-housing

### APPLICATIONS

- Drilling machines
- Vehicle applications
- Building control
- Mobile and stationary cranes
- Hydraulic leveling
- Platform leveling
- Road construction machines

The V-Series of conductive single or dual axis inclinometers offers a modern electronic in an environmentally protected and robust aluminium anodizing housing. This fully calibrated inclinometer is available with an analogue voltage output signals or current output signal. They have a compact study design and show large range of applications are possible.

## V-SERIES INCLINOMETER

### PERFORMANCE SPECIFICATIONS

	Conditions	Min	Type	Max	Unit
Measurement range		-5, -15, -45		+5, +15, +45	°
Resolution <sup>(1)</sup>		0.001		0.01	°
Accuracy	Ta = 0°...70°C	0.08, 0.15, 0.9 <sup>(4)</sup>			°
Non-linearity		1.5			%[FS]
Cross sensitivity		0.15			%[FS]
Voltage output signal <sup>(2),(3)</sup>	V, V2 unit	-2		+2	V
Voltage output signal <sup>(3)</sup>	V, V2 unit	0.5		4.5	V
Current output signal <sup>(3)</sup>	VI, V2I unit	20		4	mA
Current consumption		10		30	mA
Power supply		+12		+24	VDC
Operation temperature range		0		+70	°C
Storage temperature range		-40		+85	°C
Weight		300		320	g
Dimensions	W x D x H	90 x 60 x 45.5			mm

- (1) depend on measurement range
- (2) ratiometric to signal ground GNDx,y
- (3) depending on the circuitry wiring, see pinning schema
- (4) up to measurement range +/-30°

### DIMENSIONS [MM]

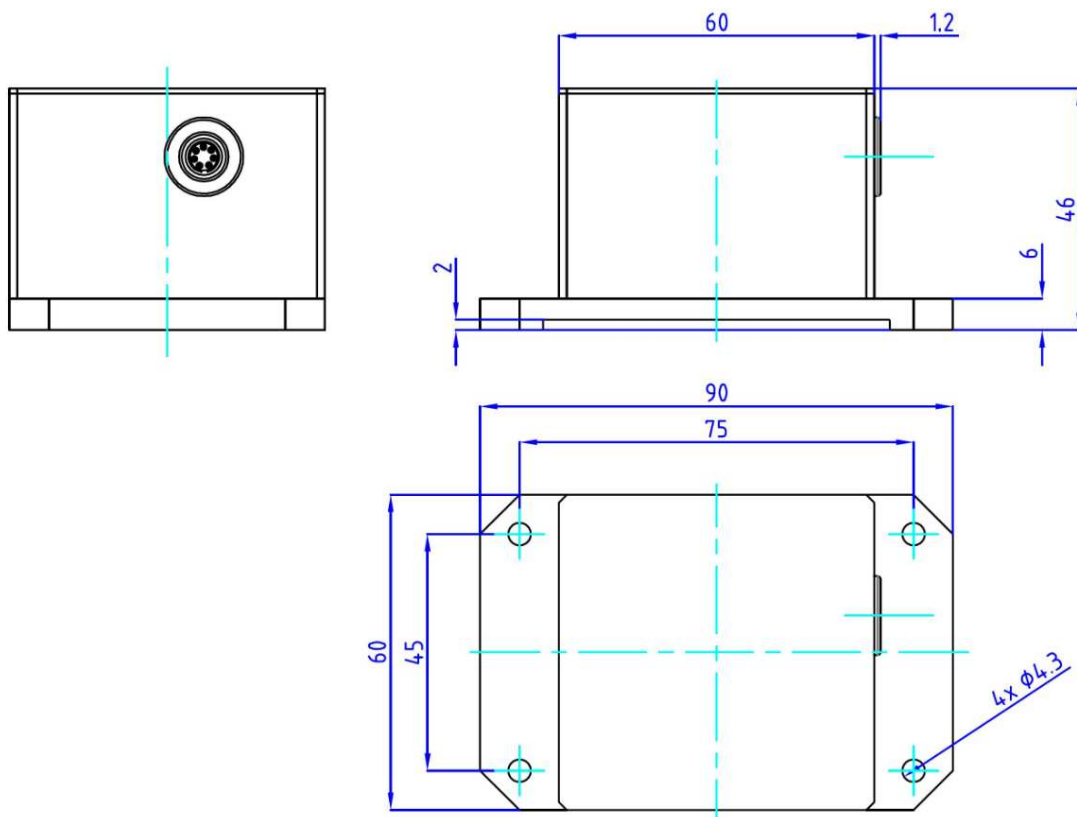

PINNING

Pinning single axis unit with voltage output signal: NS-5/V, NS-15/V, NS-45/V

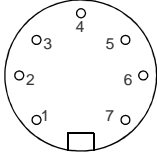

Pin	Name	Description	Type	Color schema(1)
1	Vcc	Positive power supply +12...+24VDC	Supply, Input	white
2	GND	Ground, negative supply voltage	Supply, Input	brown
3	Earth	Protection conductor	Supply, Input	green
4	GNDx	Ground for output voltage signal X axis	Output	yellow
5	n.c.	n.c.	-	grey
6	Out Vx	Output voltage signal X axis	Output	pink
7	n.c.	n.c.	-	blue

(1) By using a Measurement Specialties cable

Output connecting possibility 1

Pin 6 output voltage signal Vx x-axis

Output signal - 2V ( - 5°) to +2V ( + 5°)  
 Output signal - 2V (-15°) to +2V (+15°)  
 Output signal - 2V (-45°) to +2V (+45°)

Pin 4 GNDx analogue ground x-axis

Output connecting possibility 2

Pin 6 output voltage signal Vx x-axis

Output signal + 0,5V ( - 5°) to + 4,5V ( + 5°)  
 Output signal + 0,5V (-15°) to + 4,5V (+15°)  
 Output signal + 0.5V (-45°) to + 4,5V (+45°)

Pin 2 GND supply ground

Pinning single axis unit with current output signal: NS-5/VI, NS-15/VI, NS-45/VI

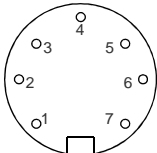

Pin	Name	Description	Type	Color schema(1)
1	Vcc	Positive power supply +12...+24VDC	Supply, Input	white
2	GND	Ground, negative supply voltage	Supply, Input	brown
3	Earth	Protection conductor	Supply, Input	green
4	GNDx	Ground for output current signal X axis	Output	yellow
5	n.c.	n.c.	-	grey
6	Out Ix	Output Current signal X axis	Output	pink
7	n.c.	n.c.	-	blue

(1) By using a Measurement Specialties cable

## V-SERIES INCLINOMETER

### Pinning dual axis unit with voltage output signal: NS-5/V2, NS-15/V2, NS-45/V2

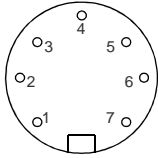

Pin	Name	Description	Type	Color schema(1)
1	Vcc	Positive power supply +12...+24VDC	Supply, Input	white
2	GND	Ground, negative supply voltage	Supply, Input	brown
3	Earth	Protection conductor	Supply, Input	green
4	GNDx	Ground for output voltage signal X axis	Output	yellow
5	GNDy	Ground for output voltage signal Y axis	Output	grey
6	Out Vx	Output voltage signal X axis	Output	pink
7	Out Vy	Output voltage signal Y axis	Output	blue

(1) By using a Measurement Specialties cable

#### Output connecting possibility 1

Pin 6,7 output voltage signal Vx x-axis, Vy y-axis

Output signal  $-2V (-5^\circ)$  to  $+2V (+5^\circ)$

Output signal  $-2V (-15^\circ)$  to  $+2V (+15^\circ)$

Output signal  $-2V (-45^\circ)$  to  $+2V (+45^\circ)$

Pin 4,5 GNDx,y analogue ground x,y-axis

#### Output connecting possibility 2

Pin 6,7 output voltage signal Vx x-axis, Vy y-axis

Output signal  $+0,5V (-5^\circ)$  to  $+4,5V (+5^\circ)$

Output signal  $+0,5V (-15^\circ)$  to  $+4,5V (+15^\circ)$

Output signal  $+0,5V (-45^\circ)$  to  $+4,5V (+45^\circ)$

Pin 2 GND supply ground

### Pinning dual axis unit with current output signal: NS-5/V2I, NS-15/V2I, NS-45/V2I

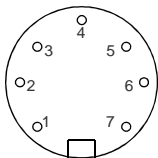

Pin	Name	Description	Type	Color schema(1)
1	Vcc	Positive power supply +12...+24VDC	Supply, Input	white
2	GND	Ground, negative supply voltage	Supply, Input	brown
3	Earth	Protection conductor	Supply, Input	green
4	GNDx	Ground for output current signal X axis	Output	yellow
5	GNDy	Ground for output current signal Y axis	Output	grey
6	Out Ix	Output Current signal X axis	Output	pink
7	Out Iy	Output Current signal Y axis	Output	blue

(1) By using a Measurement Specialties cable

## V-SERIES INCLINOMETER

### ORDERING INFORMATION

PART NUMBERING	UNIT	SHORT DESCRIPTION
<b>Single axis unit</b>		
G-NSV-001	NS- 5/V	single axis,range +/- 5°,Vcc 12 to 24VDC,output V
G-NSVI-001	NS- 5/VI	single axis,range +/- 5°,Vcc 12 to 24VDC,output I
G-NSV-002	NS-15/V	single axis,range +/-15°,Vcc 12 to 24VDC,output V
G-NSVI-003	NS-15/VI	single axis,range +/-15°,Vcc 12 to 24VDC,output I
G-NSV-005	NS-45/V	single axis,range +/-45°,Vcc 12 to 24VDC,output V
G-NSVI-006	NS-45/VI	single axis,range +/-45°,Vcc 12 to 24VDC,output I
<b>Dual axis unit</b>		
G-NSV2-001	NS- 5/V2	dual axis,range +/- 5°,Vcc 12 to 24VDC,output V
G-NSV2I-001	NS- 5/VI	dual axis,range +/- 5°,Vcc 12 to 24VDC,output I
G-NSV2-003	NS-15/V2	dual axis,range +/-15°,Vcc 12 to 24VDC,output V
G-NSV2I-003	NS-15/VI	dual axis,range +/-15°,Vcc 12 to 24VDC,output I
G-NSV2-006	NS-45/V2	dual axis,range +/-45°,Vcc 12 to 24VDC,output V
G-NSV2I-006	NS-45/VI	dual axis,range +/-45°,Vcc 12 to 24VDC,output I
<b>Accessories</b>		
G-NSMIS-001	Connection	Connector,straight, Submin.712-series
G-NSMIS-015	Connection	Connector, angle 90°, Sub min.712-series
G-NSMIS-002	Connection	2 m cable, straight connector Submin.702-series
G-NSMIS-003	Connection	2 m cable, angle 90°conn ector Submin.702-series

Other cable lenght on request

#### NORTH AMERICA

TE Connectivity Sensors, Inc.  
1000 Lucas Way  
Hampton, VA 23666  
United States  
Phone: +1-800-745-8008  
Fax: +1-757-766-4297  
Email: [customer-care.hmpt@te.com](mailto:customer-care.hmpt@te.com)  
Web: [www.te.com](http://www.te.com)

#### EUROPE

TE Connectivity Sensors  
Germany GmbH  
Hauert 13  
D-44227 Dortmund  
Germany  
Phone: +49-(0)231-9740-0  
Fax: +49-(0)231-9740-200  
Email: [customer-care.dtm@te.com](mailto:customer-care.dtm@te.com)  
Web: [www.te.com](http://www.te.com)

#### ASIA

TE Connectivity Sensors China Ltd.  
No. 26, Langshan Road  
High-tech Park (North)  
Nanshan District, Shenzhen 518057  
China  
Phone: +86-755-33305088  
Fax: +86-755-33305099  
Email: [customer-care.shzn@te.com](mailto:customer-care.shzn@te.com)

#### [www.te.com](http://www.te.com)

TE Connectivity, TE Connectivity (logo) and EVERY CONNECTION COUNTS are trademarks. All other logos, products and/or company names referred to herein might be trademarks of their respective owners.

The information given herein, including drawings, illustrations and schematics which are intended for illustration purposes only, is believed to be reliable. However, TE Connectivity makes no warranties as to its accuracy or completeness and disclaims any liability in connection with its use. TE Connectivity's obligations shall only be as set forth in TE Connectivity's Standard Terms and Conditions of Sale for this product and in no case will TE Connectivity be liable for any incidental, indirect or consequential damages arising out of the sale, resale, use or misuse of the product. Users of TE Connectivity products should make their own evaluation to determine the suitability of each such product for the specific application.

© 2017 TE Connectivity Ltd. family of companies All Rights Reserved.