

TCFS-**-***-0**-100EH

a) Part as supplied.

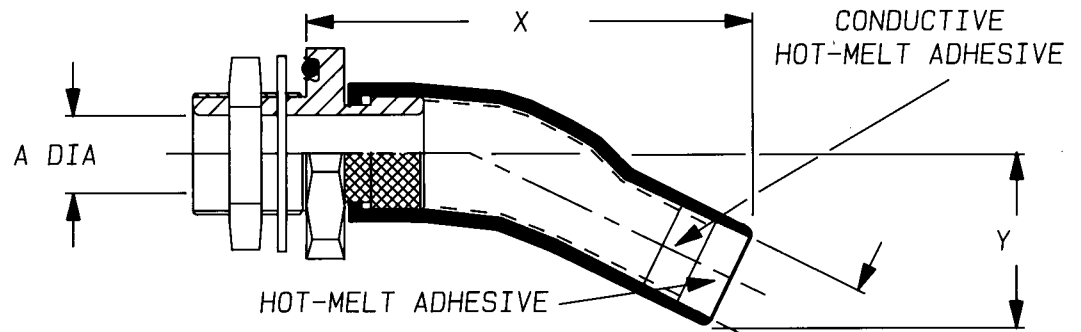

b) Part after unrestricted recovery.

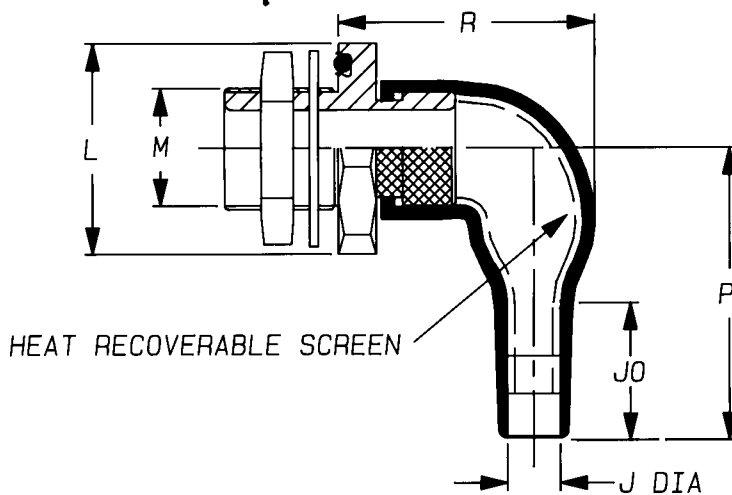

KITS TO INCLUDE CLEANING TISSUE, 1 PIECE 100 GRIT EMERY CLOTH & 1 PIECE OF ATUM.
KIT TO BE USED IN CONJUNCTION WITH TCFS INSTALLATION PROCEDURE.

Dimensions (in millimetres)

PART No.	A	J	M	A/F	L	P	R	JO	X	Y	
	min	min	max	THREAD	Nut	±10%	±10%	Ref	Ref	Ref	
	a	b				b	b	b	a	a	
TCFS-16	10.1	9	6.0	M16 x 1.5	22	29	38	33	17	57	29
TCFS-20	14.1	11	7.2	M20 x 1.5	27	34	42	36	18	63	29
TCFS-24	19.1	17	8.5	M24 x 1.5	30	38	51	43	20	74	36
TCFS-30	24.1	21	10.0	M30 x 1.5	36	47	67	50	28	90	45
TCFS-36	30.1	29	15.8	M36 x 1.5	41	52	80	59	31	111	59

Copyright (!)
Urheberrechte

The copyright in this drawing is the property of Raychem Ltd. The drawing is issued on condition that it is not copied, reproduced or disclosed to a third party, either in whole or in part without the prior written consent of Raychem Ltd.

Drawn A.LILLEY. Checked *[Signature]* Issue **3** Date November 1992 Conforms to ISO Recommendations

Approval Design *[Signature]* MKTG.

Q.C. *[Signature]*

3rd Angle Projection
Not to Scale

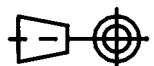

Iss.	Date	E.C.R. No.	Details of Change
2	August 1991	H0044	L was %
3	November 1992	H0125	S/S 30 L WAS 48

Material

(-100) ZERO HALOGEN

Part Numbering System.

TCFS-**-***-0**-100EH

