



**Specification RW-2500-12
TE 108-121009**

**TMS - CABLE MARKERS
TMS-CM**

Approved Signatories:

This document is electronically reviewed and approved by TE Connectivity.

TE CONNECTIVITY, SWINDON, UK

While TE Connectivity has made every reasonable effort to ensure the accuracy of the information in this specification, TE Connectivity does not guarantee that it is error-free, nor does TE Connectivity make any other representation, warranty or guarantee that the information is accurate, correct, reliable or current. TE Connectivity reserves the right to make any adjustments to the information contained herein at any time without notice. TE Connectivity expressly disclaims all implied warranties regarding the information contained herein, including, but not limited to, any implied warranties of merchantability or fitness for a particular purpose. The dimensions in this document are for reference purposes only and are subject to change without notice. Specifications are subject to change without notice. Consult TE Connectivity for the latest dimensions and design specifications.

If this document is printed it becomes uncontrolled.

1. REVISION HISTORY

Revision Number	Description of change	Date	Incorporated By
1	AFC 256	14/04/04	Alan Kean
2	AFC 406	21/02/06	Steve Rowland
3	Live in DM.TEC	24/06/10	Auto
4	Refer to PCN	16/07/14 issued 08-2015	Lee Smith

2. SCOPE

This specification sheet, when used with RW-2500, defines the product characteristics and performance of TE Connectivity TMS Cable Marker.

The printing system developed for this marker sleeve is now obsolete. TE can only guarantee the physio-chemical nature of the product, and not any marking applied using non-recommended printing systems. Where non-standard systems are used, customers are required to carry out their own validation testing.

3. REQUIREMENTS

3.1. Material

The markers shall be fabricated from irradiated, thermally-stabilized, modified polyolefin compound. The material shall be homogeneous and essentially free from flaws, defects, bubbles, cracks, or inclusions

3.2. Color

The sleeves shall be supplied in white, unless otherwise specified.

3.3. Properties

The sleeves shall meet the requirements of Table 2.

3.4. Form

The markers shall be supplied as a continuous length of carrier strip which has been specifically punched to size, in accordance with Table 1.

4. QUALITY ASSURANCE

4.1. Qualification Tests

Qualification tests are those performed on markers and marker material submitted for qualification as a satisfactory product and shall consist of all tests listed in this specification.

4.2. Acceptance Tests

Acceptance tests are those performed on markers submitted for acceptance under contract. Acceptance tests shall consist of the following: dimensions, heat shock (RW-2500).

4.3. Test Specimens

Test specimens shall be individual TMS-CM, detached from the carrier strip. Where RW-2500 is referenced as a test method, the term "marker" or "specimen" shall be understood to mean "TMS-CM".

CONFIGURATION OF CARRIER

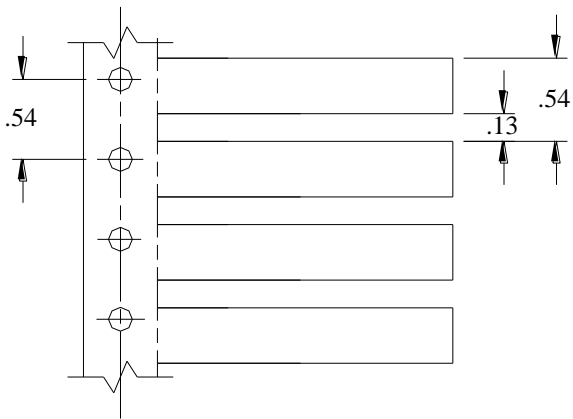

Figure 1
TMS-CM 1/4 inch size

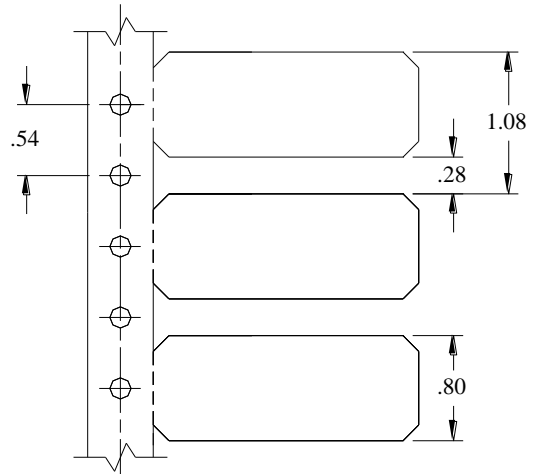

Figure 2
TMS-CM 1/2 inch size

Dimensions in inches (nominal)

TABLE 1
Cable Marker Dimensions

Part Description	Figure Number	Thickness in Inches	Number of Holes
TMS-CM-1/4-4H	4	.025	4
TMS-CM-1/2-4H	5	.025	4
TMS-CM-1/4-4H	6	.025	4
TMS-CM-1/2-6H	7	.025	6

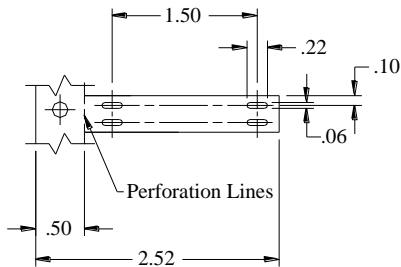

Figure 4
TMS-CM-1/4-4H

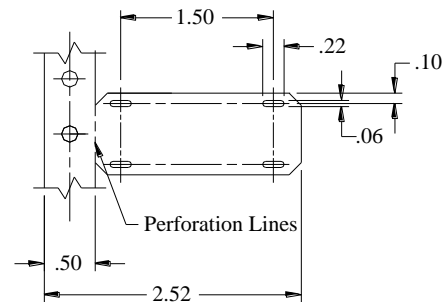

Figure 5
TMS-CM-1/2-4H

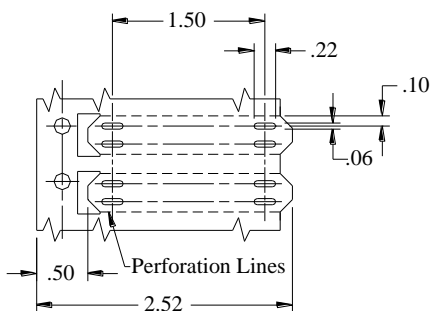

Figure 6
TMS-CM-1/2-6H

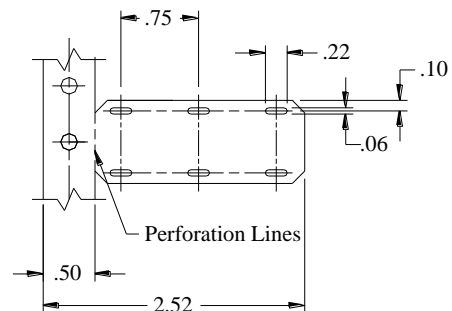

Figure 6
TMS-CM-1/2-6H

Dimensions in inches (nominal)

TE CONNECTIVITY, SWINDON, UK

While TE Connectivity has made every reasonable effort to ensure the accuracy of the information in this specification, TE Connectivity does not guarantee that it is error-free, nor does TE Connectivity make any other representation, warranty or guarantee that the information is accurate, correct, reliable or current. TE Connectivity reserves the right to make any adjustments to the information contained herein at any time without notice. TE Connectivity expressly disclaims all implied warranties regarding the information contained herein, including, but not limited to, any implied warranties of merchantability or fitness for a particular purpose. The dimensions in this document are for reference purposes only and are subject to change without notice. Specifications are subject to change without notice. Consult TE Connectivity for the latest dimensions and design specifications.

If this document is printed it becomes uncontrolled.

TABLE 2
Requirements

PROPERTY	UNIT	REQUIREMENTS	RW-2500 TEST METHOD
PHYSICAL			
Dimensions	Inches	In accordance with Table 1	RW-2500 Section 4.3.1.2
Tensile Strength	MPa (psi)	10.3 (1500) minimum	ASTM D 638 RW-2500 Section 4.3.2.2 1/8" wide die cut specimens 2 inches/ min strain rate.
Ultimate Elongation	Percent	200 minimum	
Specific Gravity	---	1.48 maximum	ASTM D 792
Low Temperature Flexibility 4 hours at -55°C (-67°F)	---	No cracking	Note 1 RW-2500 Section 4.3.5.2
Heat Shock 4 hours at 250°C (482°F)	---	No dripping, flowing or cracking	Note 2 RW-2500 Section 4.3.6.2
Heat Aging 168 hours at 175°C (347°F)	---	No cracking	Note 2 RW-2500 Section 4.3.7.2
CHEMICAL			
Corrosive Effect 16 hours at 175°C (347°F)	---	No corrosion	ASTM D 2671 Procedure A RW-2500 Section 4.3.13.2
Limiting Oxygen Index	Percent	25 minimum	ASTM D 2863
Fungus Resistance	---	Rating of 1 or less	ASTM G 21
Water Absorption 24 hours at 23°C (73°F)	Percent	0.5 maximum	ASTM D 570

Notes

1. In accordance with Section 4.3.5.2 except that specimens shall be bent 90° over a 1-inch dia. mandrel.
2. Specimens shall be bent 90° over a 5/16-inch dia. mandrel.