



PSCB SCANNER CABLE

- Pre Engineered Cable Solution
- Low Noise Shielded Cable
- PVC Jacketed / PTFE Optional

Multi-conductor ESP Scanner Cable

Features

- Molded Micro DB 15 Connectors
- Locking Screws
- Shielded Cable
- Lengths from 1 to 150 feet

Applications

- ESP Scanner interconnect cable to Pressure Scanner Interface

Wiring Diagram

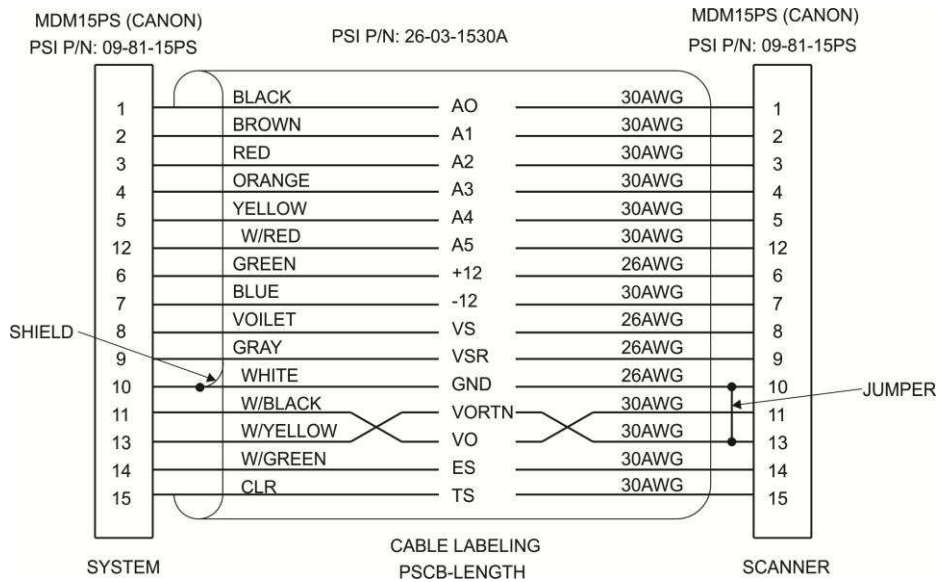

Ordering Information

PSCB-ABBBB00000 ESP SCANNER CABLE TO DTC INITIUM OR 8411, 150 FT MAX LENGTH

- A** = Material
 - 0 PVC (Standard)
 - 1 PTFE (Optional)

BBBB = Length in Feet (example: 0030 = 30 feet)

NORTH AMERICA

Measurement Specialties, Inc.,
 a TE Connectivity Company
 1000 Lucas Way
 Hampton, VA 23666 USA
 Tel +1 757 766 1500
 Fax +1 757 766 4297
Customercare.hmpt@te.com

te.com/sensorsolutions

Measurement Specialties, Inc., a TE Connectivity company.

Measurement Specialties, MEAS, TE Connectivity, TE Connectivity (logo) and EVERY CONNECTION COUNTS are trademarks. All other logos, products and/or company names referred to herein might be trademarks of their respective owners.

The information given herein, including drawings, illustrations and schematics which are intended for illustration purposes only, is believed to be reliable. However, TE Connectivity makes no warranties as to its accuracy or completeness and disclaims any liability in connection with its use. TE Connectivity's obligations shall only be as set forth in TE Connectivity's Standard Terms and Conditions of Sale for this product and in no case will TE Connectivity be liable for any incidental, indirect or consequential damages arising out of the sale, resale, use or misuse of the product. Users of TE Connectivity products should make their own evaluation to determine the suitability of each such product for the specific application.

© 2016 TE Connectivity Ltd. family of companies All Rights Reserved.