

# OPERATION MANUAL MODEL 8011-01 & 8021-01 ACCELEROMETER

---

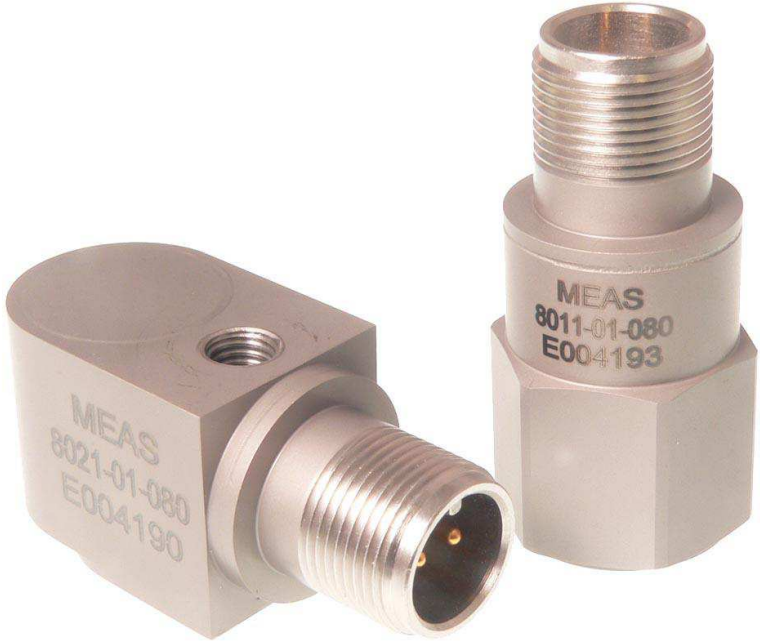

### WARRANTY

Measurement Specialties, Inc. accelerometers are warranted during a period of one year from date of shipment to original purchaser to be free from defects in material and workmanship. The liability of Seller under this warranty is limited to replacing or repairing any instrument or component thereof which is returned by Buyer, at his expense, during such period and which has not been subjected to misuse, neglect, improper installation, repair, alteration, or accident. Seller shall have the right to final determination as to the existence and cause of a defect. In no event shall Seller be liable for collateral or consequential damages. This warrant is in lieu of any other warranty, expressed, implied, or statutory; and no agreement extending or modifying it will be binding upon Seller unless in writing and signed by a duly authorized officer.

### RECEIVING INSPECTION

Every Measurement Specialties, Inc. accelerometer is carefully inspected and is in perfect working condition at the time of shipment. Each accelerometer should be checked as soon as it is received. If the unit is damaged in any way, or fails to operate, a claim should immediately be filed with the transportation company.

### SERVICE CONCERNS

If a Measurement Specialties, Inc. instrument requires service, first contact the nearest Measurement Specialties, Inc. representative. They may be able to solve the problem without returning the unit to the factory. If it is determined that factory service is required, call Customer Service at the regional headquarters for an RMA number before return.

### RETURNS

All units being returned to the factory require an RMA (Return Material Authorization) number before they will be accepted. This number may be obtained by calling Customer Service at the regional headquarters with the following information; model number(s), quantity, serial number(s), and symptoms of the problem, if being returned for service. You must include the original purchase order number if under warranty.

### RECALIBRATION SERVICES

The Vibration Sensors Design Center and its two manufacturing facilities in China and France offer factory re-calibration services for Piezoresistive, Piezoelectric and Integrated Electronics Piezoelectric (IEPE, ISOTRON, ICP, etc.) accelerometers. NIST (US), DKD (Germany), COFRAC (France) traceable calibration services on sensitivity at 100 Hz (102 or 120 Hz in Europe) and full frequency sweeps are offered. Contact the regional headquarters for pricing information.

# MODEL 8011-01 & 8021-01 ACCELEROMETER

## DESCRIPTION

The Model 8011-01 & 8021-01 are rugged industrial IEPE accelerometers available in  $\pm 10g$  to  $\pm 500g$  dynamic ranges with bandwidth up to greater than 16kHz (depending on range). The accelerometers feature a MIL-C-5015 connector with model 8011 having a top connector and model 8021 having a side connector. The units are hermetically sealed and are designed to operating in temperature ranges from  $-55^{\circ}\text{C}$  to  $+125^{\circ}\text{C}$ .

## INSTALLATION

The model 8011 accelerometer is designed to be stud mounted while the model 8021 accelerometer is designed to be screw mounted. However, both can also be adhesively mounted with an adhesive mounting adaptor or mounted with a magnetic mounting adaptor (for 8011 only).

### Stud Mounting (model 8011)

For model 8011, the provided AC-A03663 stud should be used. This stud is designed for  $1/4$ -28 thread mounting, please contact the factory for other stud adaptor options. The following guidelines should be followed:

- The mounting surface should be clean and free of any residue or foreign material.
- The mounting surface should be smooth, flat, and with a maximum surface roughness of 32 micro-inches rms.
- Apply a light coating of coupling fluid (machine oil or silicone grease) on the mating surface to maximize the usable frequency range.
- Torque mounting stud to 24 in-lbs (2.7 N-m)

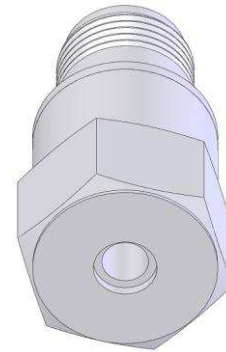
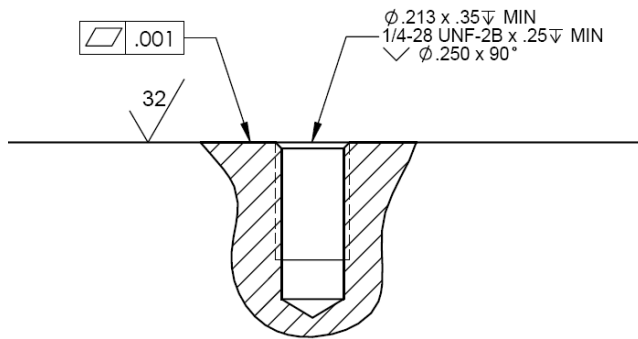

### Screw Mounting (model 8021)

For model 8021, the captive screw AC-A03735 should be used. This screw is designed for  $1/4$ -28 thread mounting, please contact factory for other captive screw options. The following guidelines should be followed:

- The mounting surface should be clean and free of any residue or foreign material.
- The mounting surface should be smooth, flat, and with a maximum surface roughness of 32 micro-inches rms.
- Apply a light coating of coupling fluid (machine oil or silicone grease) on the mating surface to maximize the usable frequency range.
- Torque mounting stud to 24 in-lbs (2.7 N-m)

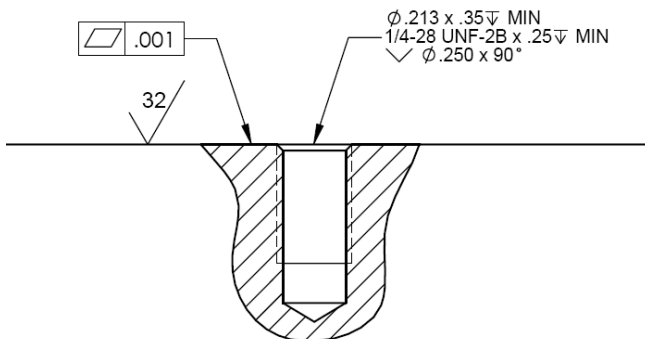

## MODEL 8011-01 & 8021-01 ACCELEROMETER

---

### Adhesive Mounting

To avoid damaging the accelerometer during subsequent removal, it is recommended to use an adhesive mounting adaptor for this method of attachment. For adhesively mounting of accelerometers the following guidelines should be followed:

- The mounting surface should be clean and free of any residue or foreign material.
- The mounting surface should be smooth, flat, and with a maximum surface roughness of 64 micro-inches rms.
- For best high frequency performance a cyanoacrylate adhesive is recommend. A thin layer offers best frequency response.
- Soften adhesive cured adhesive with a chemical debonder (eg. acetone) prior to removal. Gently shear accelerometer loose from the mounting surface after waiting a few minutes for the debonding agent to penetrate the epoxy. Make sure not to use excessive force as this may damage the accelerometer.

### Magnet Mounting

For magnetic mounting (model 8011 only) a magnetic mounting adaptor should be used. Magnetic mounting offers a quick and easy installation portable installation method that is convenient for easy removals. For magnetic mounting of accelerometers the following guidelines should be followed:

- Verify that the mounting surface is magnetic and flat.
- The mounting surface should be clean and free of any residue or foreign material.
- The mounting surface should be smooth, flat, and with a maximum surface roughness of 64 micro-inches rms.
- Inspect the magnet surface of the adaptor which should also be clean and free of any residue or foreign material.
- Install the magnetic mounting adaptor on the accelerometer first. Torque to 24 in-lbs (2.7 N-m).
- Gently mount the accelerometer with adaptor to the mounting surface. Do NOT drop the accelerometer onto the mounting surface as this could potentially generate very high g-levels that can damage the accelerometer.
- Note that poor installation can drastically affect the frequency response of the accelerometer.

## MODEL 8011-01 & 8021-01 ACCELEROMETER

### WIRING

The model 8011-01 & 8021-01 are IEPE type accelerometers that are designed for constant current excitation. The operator can connect the accelerometers to standard IEPE signal conditioners or construct their own constant current excitation circuitry. Consult with TE Connectivity application support to confirm that the user selected signal conditioner is compatible with the 8011-01 & 8021-01 accelerometers.

#### IEPE (Integral Electronics Piezoelectric) Accelerometer Schematic

IEPE accelerometers can be operated into readout devices (i.e. oscilloscope), or into the voltage input stage of a signal conditioner without the use of a conventional charge converter/amplifier. Below is the schematic for the basic setup. There are several ways to supply a constant current. The simplest set-up consists of a current regulating diode or diodes in parallel with a battery.

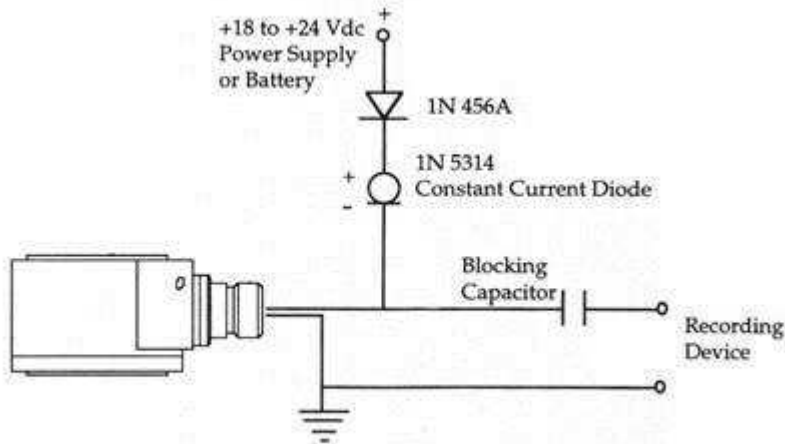

#### Constant Current

Most IEPE accelerometers can be operated from as low as 2 mA of constant current. Higher current levels (up to 10 mA for model 8011-01 & 8021-01) may be required depending on the load and the desired frequency response. In normal applications, 4 mA is recommended. The model 8011-01 & 8021-01 accelerometers can operate at a compliance voltage from 18 to 30 Vdc with an excitation current of 2 to 10 mA.

#### Compliance Voltage and Bias Voltage

Compliance voltage is defined as the maximum DC voltage available from the constant current source. Bias voltage is the quiescent DC voltage appearing at the output of the IEPE accelerometer in static condition (no vibration). Together they determine the signal transfer characteristic of the IEPE accelerometer. Below shows the typical transfer characteristics of a unity gain IEPE internal preamplifier.

## MODEL 8011-01 & 8021-01 ACCELEROMETER

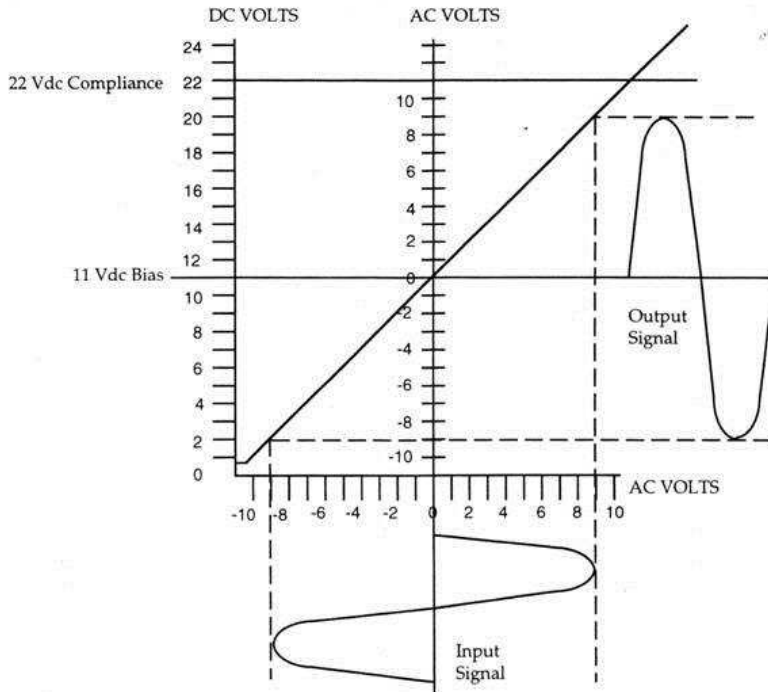

In reference to the illustration above, the compliance voltage is available at 22 Vdc. The bias voltage is set by the accelerometer internal preamplifier at 11 Vdc, and the sensor produces an 18V pk-pk input signal. Under these conditions, the internal preamplifier can produce a distortion-free 18V pk-pk output. However, distortion (otherwise known as clipping) may occur with one or more of the following conditions:

1. Input signal exceeds 20V pk-pk.
2. Compliance voltage drops below 20 Vdc.
3. The bias level of the accelerometer shifts significantly (temperature change if not temp compensated).

Most IEPE accelerometers are capable of producing linear output up to 18V pk-pk under ideal conditions (conservatively, a maximum full scale output of 10 V pk-pk).

### Constructing a Constant Current Supply

Many data acquisition systems on the market today has the ability to supply a constant current supply. There are also many small stand-alone constant current supply's available (1 channel boxes up to 16 channel 19 inch rack mount modules as well).

However, for those that want to construct their own constant current supply, polarity of the power supply voltage must be correctly connected to the constant current diode. If the polarity of the voltage source is reversed, an unlimited amount of current may be going to the IEPE accelerometer and cause permanent damage to the internal electronics of the accelerometer. It is therefore recommended to put a regulating diode (polarity reversal protection) in series with the constant current diode as depicted in the IEPE schematic above.

## CABLE ROUTING

The model 8011 & 8021 accelerometers incorporate a 2-pin connector with a detachable mating cable assembly (model 316 or model 318). For reliable operation it is recommended that a small amount of thread locking compound is used to secure the connector plug during testing. The cable assembly should also be properly secured at regular intervals during testing. It is recommended to use clamps, wax, or tape to secure the cable to minimize cable motion that can add noise to the output signal. The initial attachment should be within two to three inches of the accelerometer. Avoid routing cables near high-voltage wires and also ground the shield at the signal conditioner to minimize ground loops.

## TEMPERATURE RESPONSE

The model 8011-01 & 8021-01 accelerometers are designed to operate from -55°C to +125°C (-67°F to +257°F). The typical temperature response curve is illustrated below.

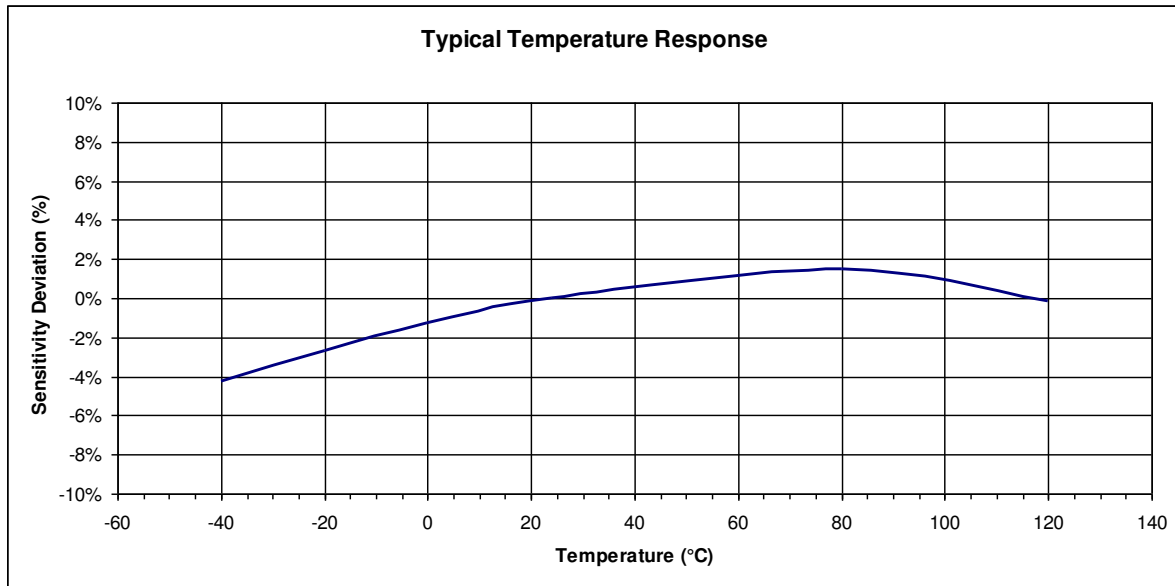

### NORTH AMERICA

Measurement Specialties, Inc.,  
a TE Connectivity Company  
1000 Lucas Way  
Hampton, VA 23666  
United States  
Tel: +1 757 766 1500  
Email: [customercare.hmpt@te.com](mailto:customercare.hmpt@te.com)

Measurement Specialties, Inc.,  
a TE Connectivity Company  
Vibration Sensors Design Center  
32 Journey, Suite 150  
Aliso Viejo, CA 92656, USA  
Tel: +1 949 716 7324

### [te.com/sensorsolutions](http://te.com/sensorsolutions)

Measurement Specialties, Inc., a TE Connectivity company.

Measurement Specialties (MEAS), American Sensor Technologies (AST), TE Connectivity, TE Connectivity (logo) and EVERY CONNECTION COUNTS are trademarks. All other logos, products and/or company names referred to herein might be trademarks of their respective owners.

The information given herein, including drawings, illustrations and schematics which are intended for illustration purposes only, is believed to be reliable. However, TE Connectivity makes no warranties as to its accuracy or completeness and disclaims any liability in connection with its use. TE Connectivity's obligations shall only be as set forth in TE Connectivity's Standard Terms and Conditions of Sale for this product and in no case will TE Connectivity be liable for any incidental, indirect or consequential damages arising out of the sale, resale, use or misuse of the product. Users of TE Connectivity products should make their own evaluation to determine the suitability of each such product for the specific application.

© 2016 TE Connectivity Ltd. family of companies All Rights Reserved.

### EUROPE

MEAS Deutschland GmbH  
a TE Connectivity Company  
Impasse Jeanne BENOZZI  
CS 83 163, 31027 Toulouse Cedex 3, France  
Tel: +33 (0) 582 08 22 00  
Email: [customercare.tlse@te.com](mailto:customercare.tlse@te.com)

### ASIA

Measurement Specialties China Ltd.,  
a TE Connectivity Company  
No. 26, Langshan Road  
Shenzhen High-tech Park (North)  
Nanshan District, Shenzhen 518057  
China  
Phone: +86-755-3330-5088  
Email: [customercare.shzn@te.com](mailto:customercare.shzn@te.com)