

OPERATION MANUAL MODEL 3801A ACCELEROMETER



WARRANTY

Measurement Specialties, Inc. accelerometers are warranted during a period of one year from date of shipment to original purchaser to be free from defects in material and workmanship. The liability of Seller under this warranty is limited to replacing or repairing any instrument or component thereof which is returned by Buyer, at his expense, during such period and which has not been subjected to misuse, neglect, improper installation, repair, alteration, or accident. Seller shall have the right to final determination as to the existence and cause of a defect. In no event shall Seller be liable for collateral or consequential damages. This warrant is in lieu of any other warranty, expressed, implied, or statutory; and no agreement extending or modifying it will be binding upon Seller unless in writing and signed by a duly authorized officer.

RECEIVING INSPECTION

Every Measurement Specialties, Inc. accelerometer is carefully inspected and is in perfect working condition at the time of shipment. Each accelerometer should be checked as soon as it is received. If the unit is damaged in any way, or fails to operate, a claim should immediately be filed with the transportation company.

SERVICE CONCERNS

If a Measurement Specialties, Inc. instrument requires service, first contact the nearest Measurement Specialties, Inc. representative. They may be able to solve the problem without returning the unit to the factory. If it is determined that factory service is required, call Customer Service at the regional headquarters for an RMA number before return.

RETURNS

All units being returned to the factory require an RMA (Return Material Authorization) number before they will be accepted. This number may be obtained by calling Customer Service at the regional headquarters with the following information; model number(s), quantity, serial number(s), and symptoms of the problem, if being returned for service. You must include the original purchase order number if under warranty.

RECALIBRATION SERVICES

The Vibration Sensors Design Center and its two manufacturing facilities in China and France offer factory re-calibration services for Piezoresistive, Piezoelectric and Integrated Electronics Piezoelectric (IEPE, ISOTRON, ICP, etc.) accelerometers. NIST (US), DKD (Germany), COFRAC (France) traceable calibration services on sensitivity at 100 Hz (102 or 120 Hz in Europe) and full frequency sweeps are offered. Contact the regional headquarters for pricing information.

MODEL 3801A ACCELEROMETER

DESCRIPTION

The Model 3801A is a stud mounted MEMS accelerometer packaged in a welded stainless steel housing. The accelerometer incorporates a miniature side-mounted connector with a detachable mating cable assembly. The Model 3801A is offered in ranges from ± 2 to $\pm 2000g$ and incorporates mechanical stops for over-range protection up to 10,000g. The gas damped accelerometer offers a wide bandwidth that is ideal for structural and impact testing.

INSTALLATION

The model 3801A accelerometer is designed to be stud mounted but can also be adhesively mounted with an adhesive mounting adaptor if the installation does not allow for stud mounting.

Stud Mounting

For stud mounting the provided AC-D02298 stud should be used. The following guidelines should be followed:

- The mounting surface should be clean and free of any residue or foreign material.
- The mounting surface should be smooth, flat, and with a maximum surface roughness of 32 micro-inches rms.
- Apply a light coating of coupling fluid (machine oil or silicone grease) on the mating surface to maximize the usable frequency range.
- Torque mounting stud to 18 in-lbs.

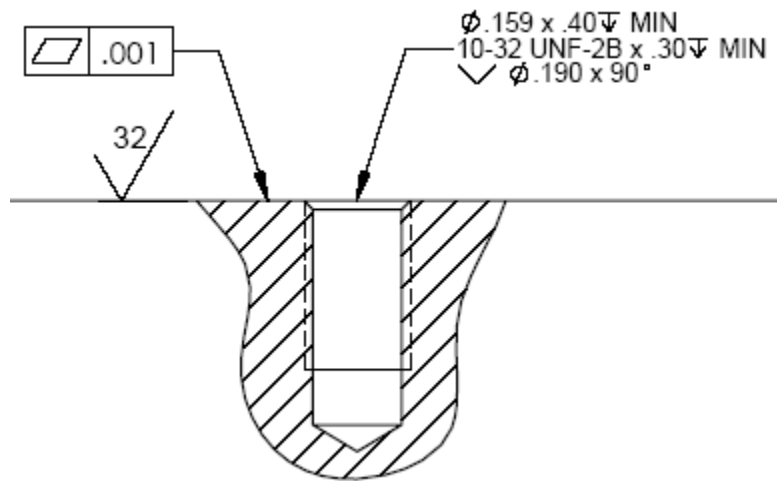

MODEL 3801A ACCELEROMETER

Adhesive Mounting

To avoid damaging the accelerometer during subsequent removal, it is recommended to use an adhesive mounting adaptor for this method of attachment (model AC-D02741 adaptor is offered). For adhesively mounting of accelerometers the following guidelines should be followed:

- The mounting surface should be clean and free of any residue or foreign material.
- The mounting surface should be smooth, flat, and with a maximum surface roughness of 64 micro-inches rms.
- For best high frequency performance a cyanoacrylate adhesive is recommend. A thin layer offers best frequency response.
- Soften adhesive cured adhesive with a chemical debonder (eg. acetone) prior to removal. Gently shear accelerometer loose from the mounting surface after waiting a few minutes for the debonding agent to penetrate the epoxy. Make sure not to use excessive force as this may damage the accelerometer.

CABLE ROUTING

The model 3801A accelerometer incorporates a miniature side-mounted connector with a detachable mating cable assembly (model 340). For reliable operation it is recommend that a small amount of thread locking compound is used to secure the connector plug during testing. For long term use in a wet or oily environment it is recommended that the connector interface is protected with a silicone sealant and a flexible heat shrink tubing.

The cable assembly should also be properly secured at regular intervals during testing. It is recommended to use clamps, wax, or tape to secure the cable to minimize cable motion that can add noise to the output signal. The initial attachment should be within two to three inches of the accelerometer.

Avoid routing cables near high-voltage wires and also ground the shield at the signal conditioner to minimize ground loops.

EXCITATION

The model 3801A is a piezo-resistive (PR) accelerometer that requires a clean and stable, low noise dc power supply or battery supply. The output sensitivity is ratiometric to excitation voltage so any ripple in the excitation will affect the sensitivity accordingly. The accelerometers are calibrated at 10Vdc excitation but can also be used with an excitation voltage from 2-10Vdc. However, it is recommended that you contact the Vibration Application Support prior to using a non-standard excitation voltage as it will affect the calibrated sensitivity, ZMO, and TC errors.

The sensor element used in the model 3801A accelerometer is a MEMS device with some operating characteristics that are different than a purely resistive Wheatstone bridge. There is a parasitic PN junction in series with the bridge. **For this reason the positive and negative excitation voltages should not be reversed.** Internal heating and possible damage to the unit will result. The accelerometer also has a TCS compensation circuit with a semiconductor device in series with the positive excitation terminal. **Reverse current may damage this device.**

SIGNAL CONDITIONING

The model 3801A accelerometer incorporates a PR Wheatstone-bridge sensing element with true differential signal outputs. The positive and negative outputs of the unit should be connected to differential input amplifiers with an input impedance of at least 1 Meg Ohm referred to ground. The amplifier should also have good common mode rejection and a suitable bandwidth for the application.

In situations where the signal-conditioning amplifier has a single-ended input, one of the outputs should be left unconnected (with the sensitivity reduced to $\frac{1}{2}$ the specified value). **The unused output should not be tied to ground or any low impedance.** Grounding the unused output will result in a short circuit across half of the bridge. This will have an adverse affect on the operation of the sensor. The increased current flowing through one half of the bridge will cause the bridge to be unbalanced with unequal heating and unpredictable results from the other half of the bridge.

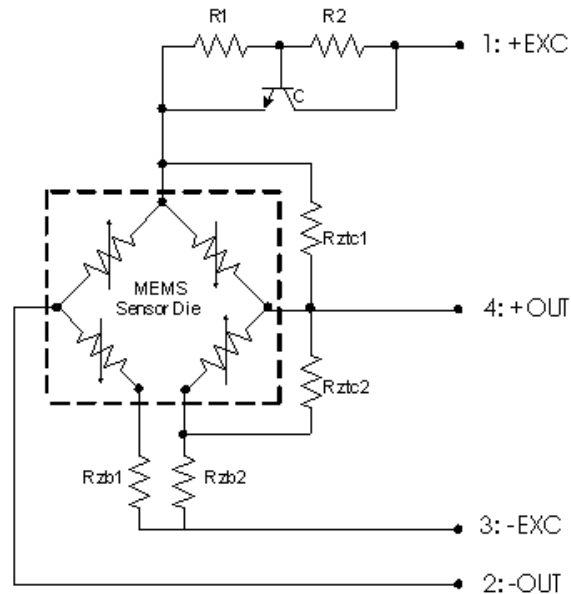

Note: Either Rzb1 or Rzb2 is installed, not both. If Rzb1 is installed then Rzb2 is shorted.
Either Rzc1 or Rzc2 is installed, not both. If Rzc1 is installed then Rzc2 is left open.

NORTH AMERICA

Measurement Specialties, Inc.,
a TE Connectivity Company
1000 Lucas Way
Hampton, VA 23666
United States
Tel: +1 757 766 1500
Email: customer-care.hmpt@te.com

Measurement Specialties, Inc.,
a TE Connectivity Company
Vibration Sensors Design Center
32 Journey, Suite 150
Aliso Viejo, CA 92656, USA
Tel: +1 949 716 7324

te.com/sensorsolutions

Measurement Specialties, Inc., a TE Connectivity company.

Measurement Specialties (MEAS), American Sensor Technologies (AST), TE Connectivity, TE Connectivity (logo) and EVERY CONNECTION COUNTS are trademarks. All other logos, products and/or company names referred to herein might be trademarks of their respective owners.

The information given herein, including drawings, illustrations and schematics which are intended for illustration purposes only, is believed to be reliable. However, TE Connectivity makes no warranties as to its accuracy or completeness and disclaims any liability in connection with its use. TE Connectivity's obligations shall only be as set forth in TE Connectivity's Standard Terms and Conditions of Sale for this product and in no case will TE Connectivity be liable for any incidental, indirect or consequential damages arising out of the sale, resale, use or misuse of the product. Users of TE Connectivity products should make their own evaluation to determine the suitability of each such product for the specific application.

© 2016 TE Connectivity Ltd. family of companies All Rights Reserved.

EUROPE

MEAS Deutschland GmbH
a TE Connectivity Company
105 av. du Général Eisenhower
BP 1036, 31023 Toulouse Cedex,
France
Tel: +33 (0) 561 194 543
Email: customer-care.tlse@te.com

ASIA

Measurement Specialties China Ltd.,
a TE Connectivity Company
F1.6-4D, Tian An Development Compound
Shenzhen, China 518048
Tel: +86 755 8330 1004
Email: customer-care.shzn@te.com