

LOC		DIST		REVISIONS			
GE	00	YR		DESCRIPTION	DATE	DN	APVD
		0		RELEASED	04JUN99	PY	JK

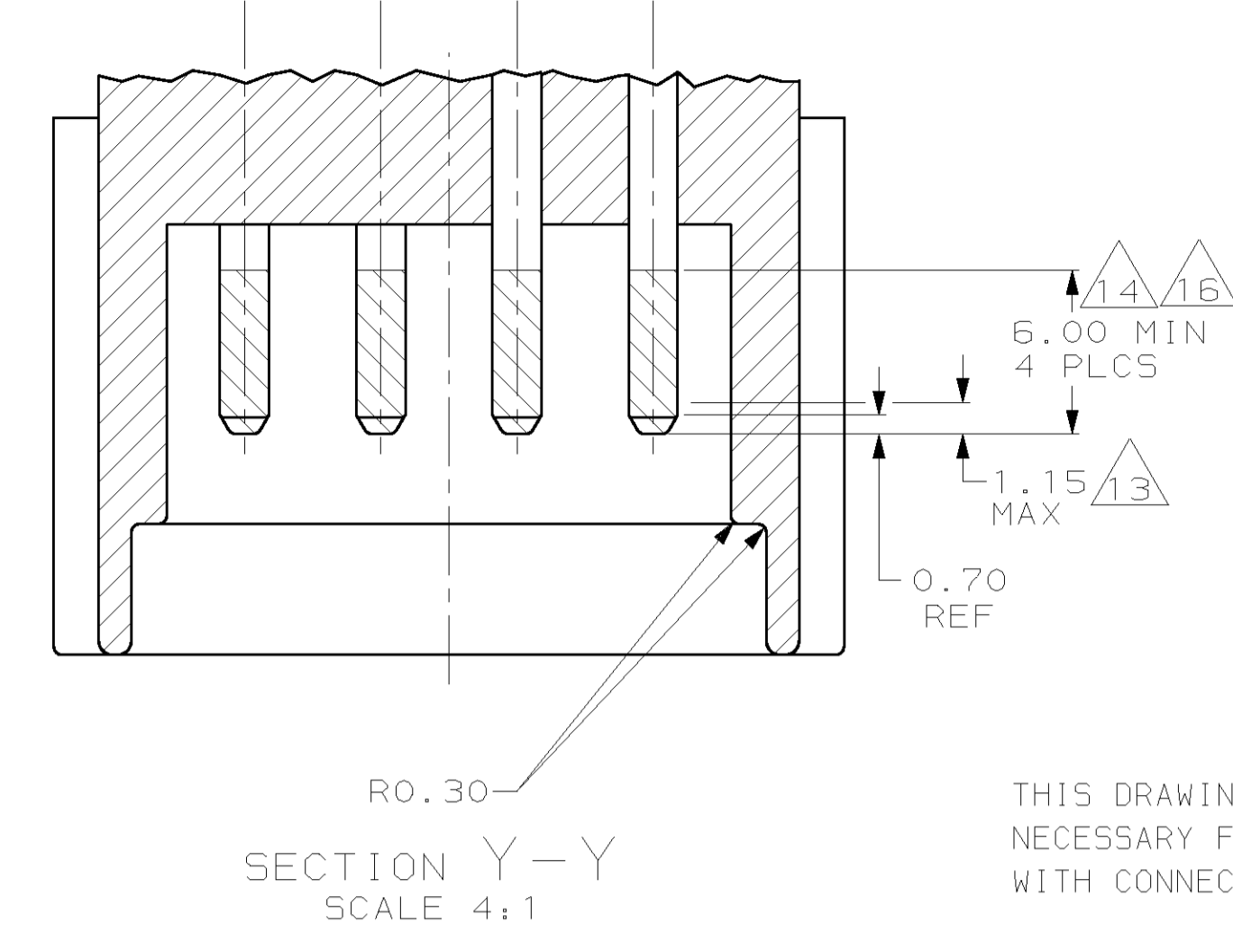

THIS DRAWING DEFINES THE DIMENSIONAL INTERFACE REQUIREMENTS NECESSARY FOR AN ELECTRICAL/MECHANICAL SENSOR DEVICE TO MATE WITH CONNECTOR PLUG ASSEMBLIES PROVIDED BY AMP INCORPORATED.

- 1 AT -D- 13.45 MAX AT -E-
- 2 AT -D- 26.15 MAX AT -E-
- 3 AT -C- 7.7 MAX AT -F-
- 4 AT -E- 1.6 MIN AT -C-
- 5 AT -D- 30.0 MAX AT -E-
- 6 AT -E- 4.5 MIN AT -C-
- 7 AT -E- 11.35 MAX AT -D-
- 8 AT -E- 13.25 MIN AT -D-
- 9. 1/2° MAX DRAFT ANGLE EXCEPT AS INDICATED
- 10. WARPAGE 0.1 MAX AND FLASH 0.15 MAX
- 11. SURFACE DEFECTS ARE NOT ACCEPTABLE AS FOLLOWS: TOOL LINES, WITNESS LINES, WELD LINES, HAIR CRACKS, STAINS AND SCORES.
- 12. ALL RADII ARE 0.5, EXCEPT AS INDICATED.
- 13. BURR FREE LEAD-IN TO PREVENT STUBBING OR SCRAPING.
- 14. FINISH: 0.0020 MIN THICK NICKEL UNDERPLATE WITH 0.00076 MIN THICK GOLD OR 0.0038/0.0076 THICK TIN IN MATING AREA WITH NO EXPOSED EDGES.
- 15. 0.640±0.025 THICK X 1.80±0.10 WIDE CONTACT, LOCATED AS SHOWN.
- 16. NO TOOL MARKS PERMITTED IN THIS AREA.

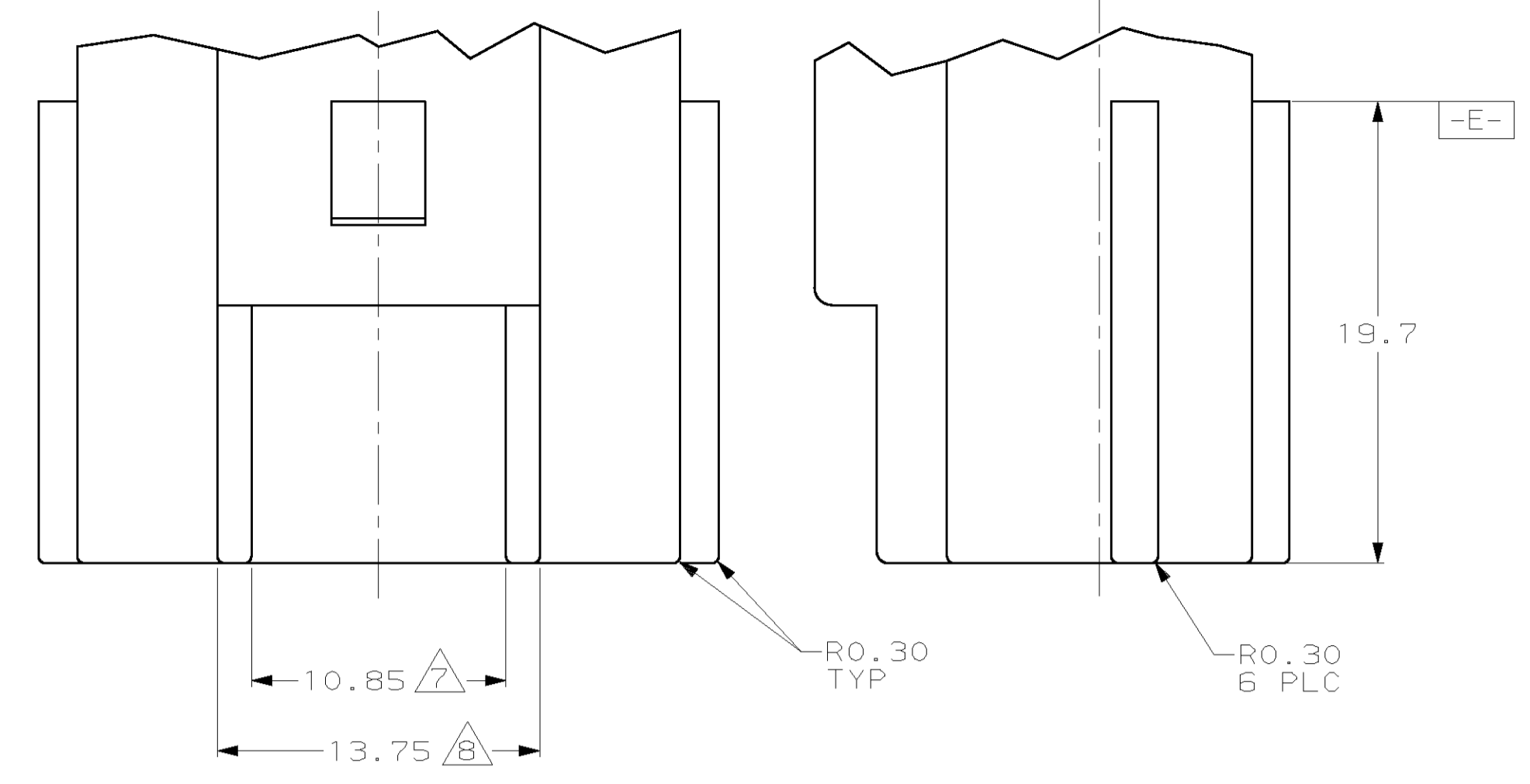
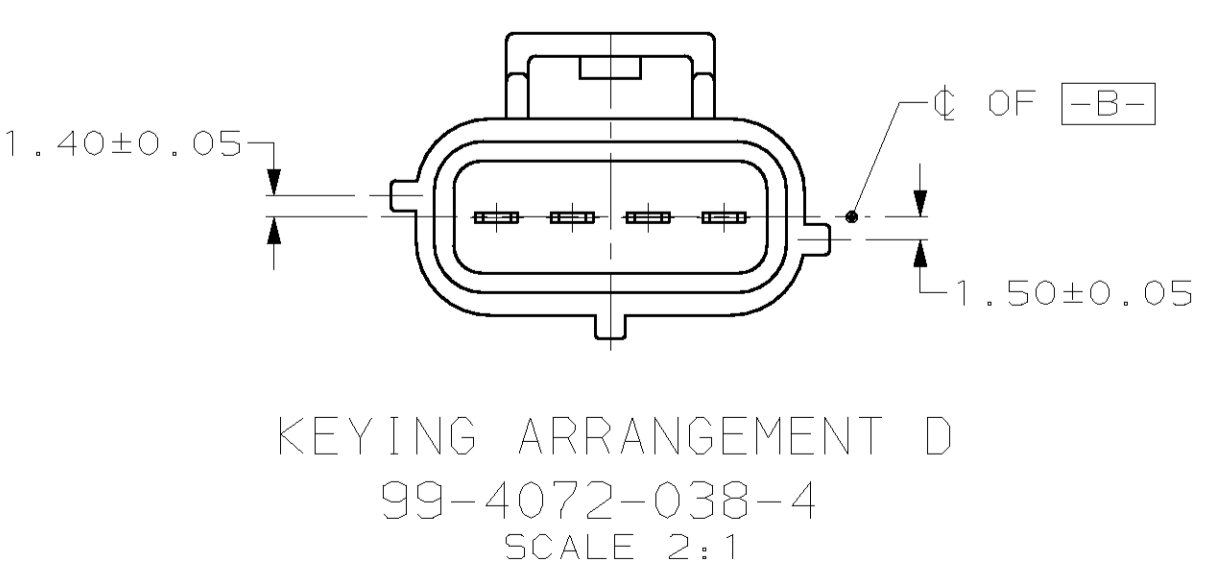
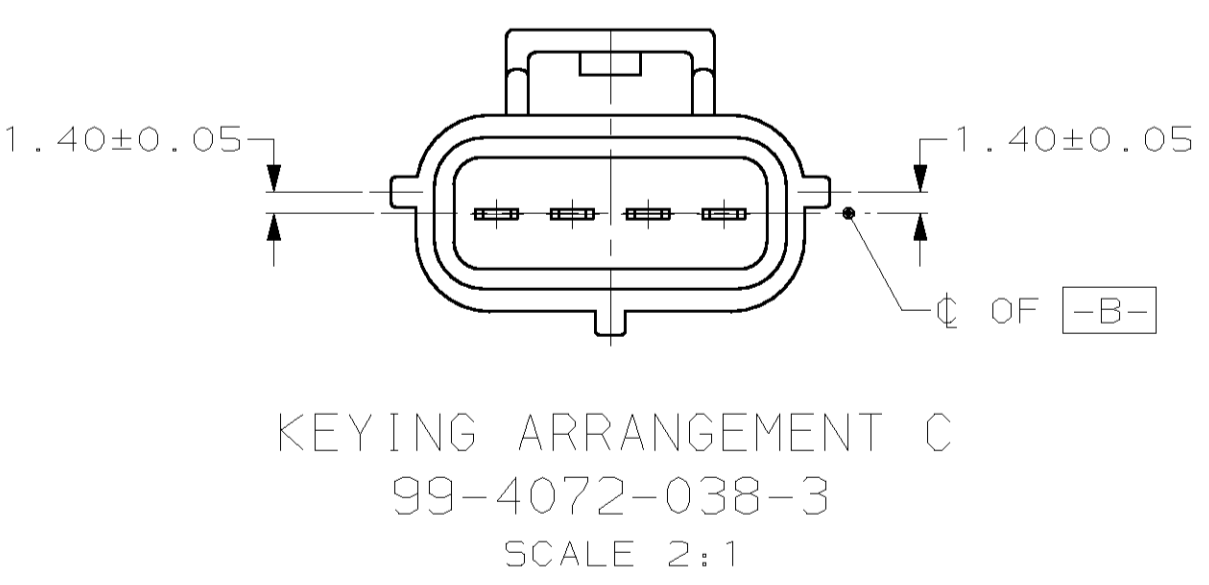
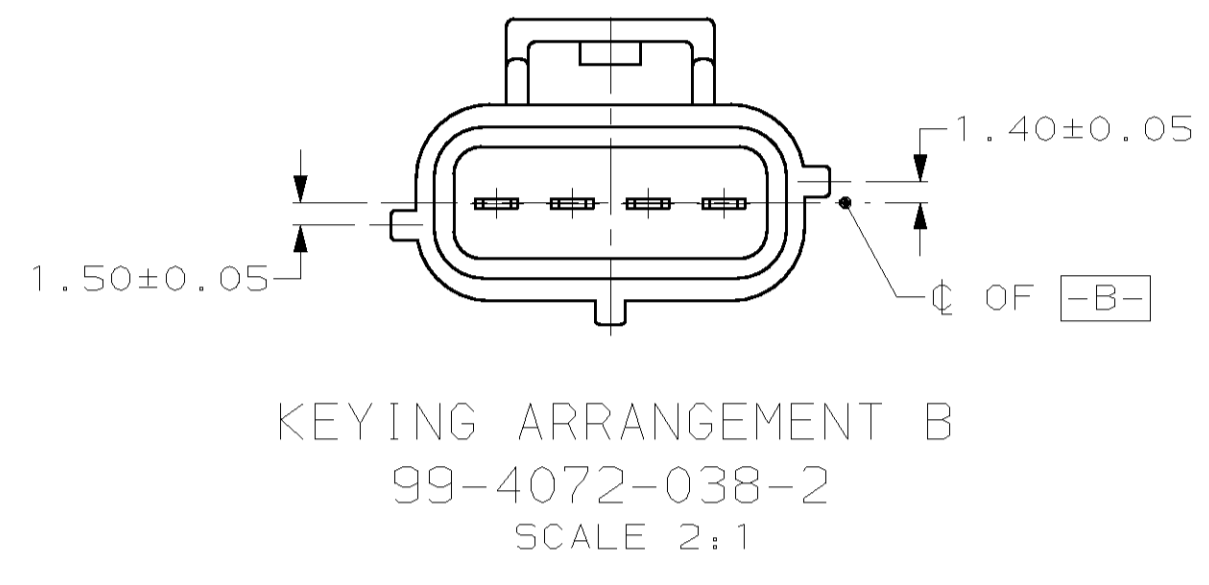
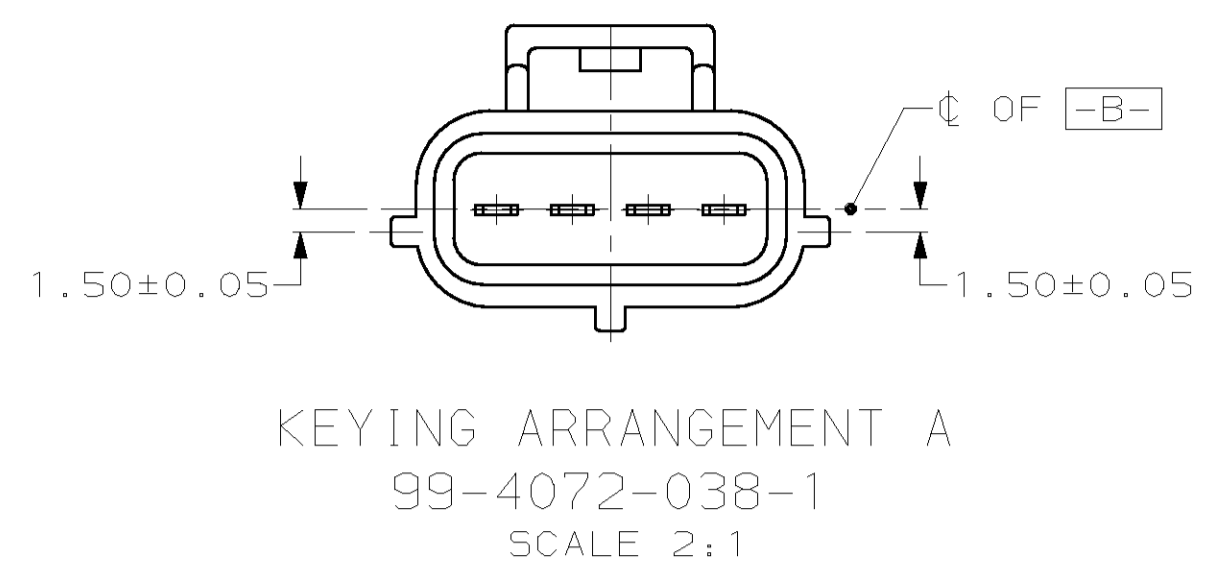
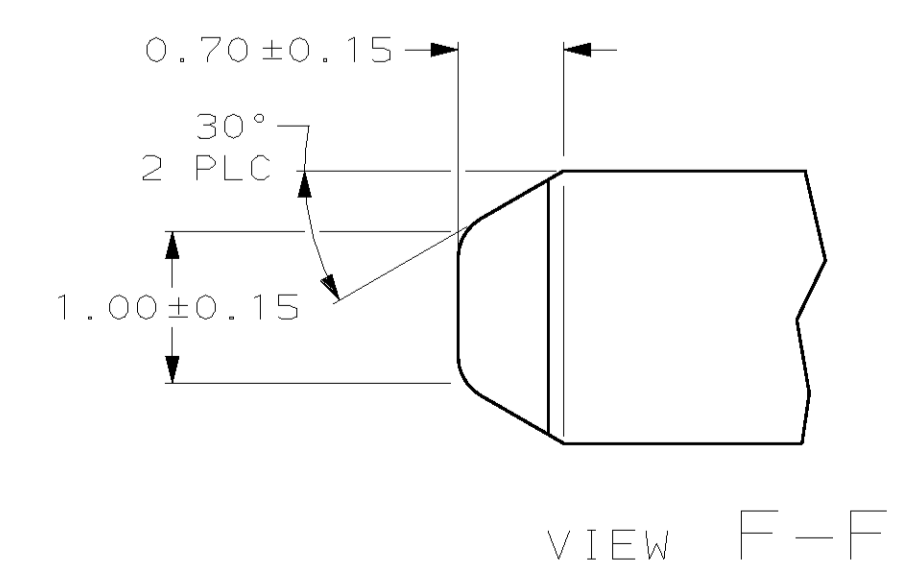
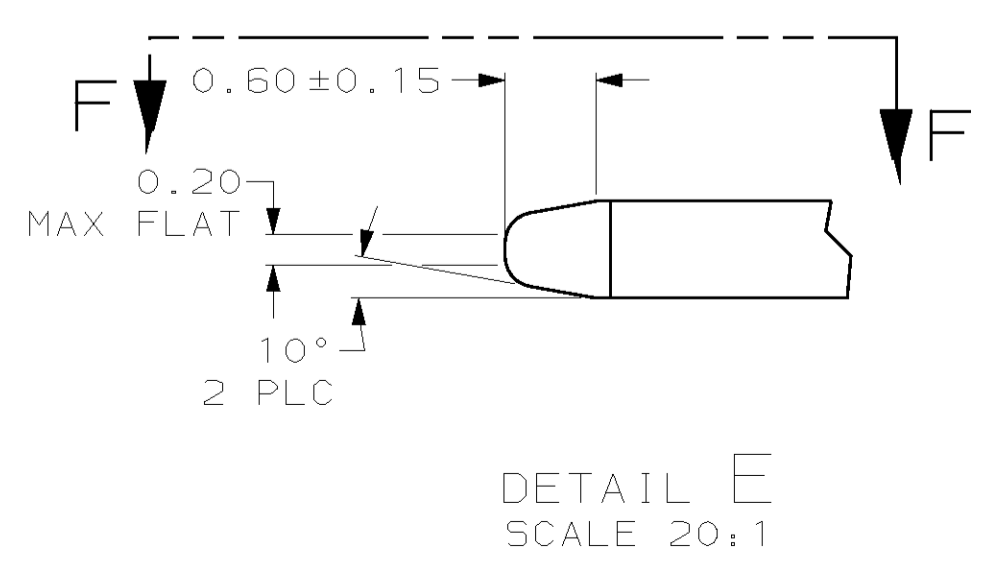
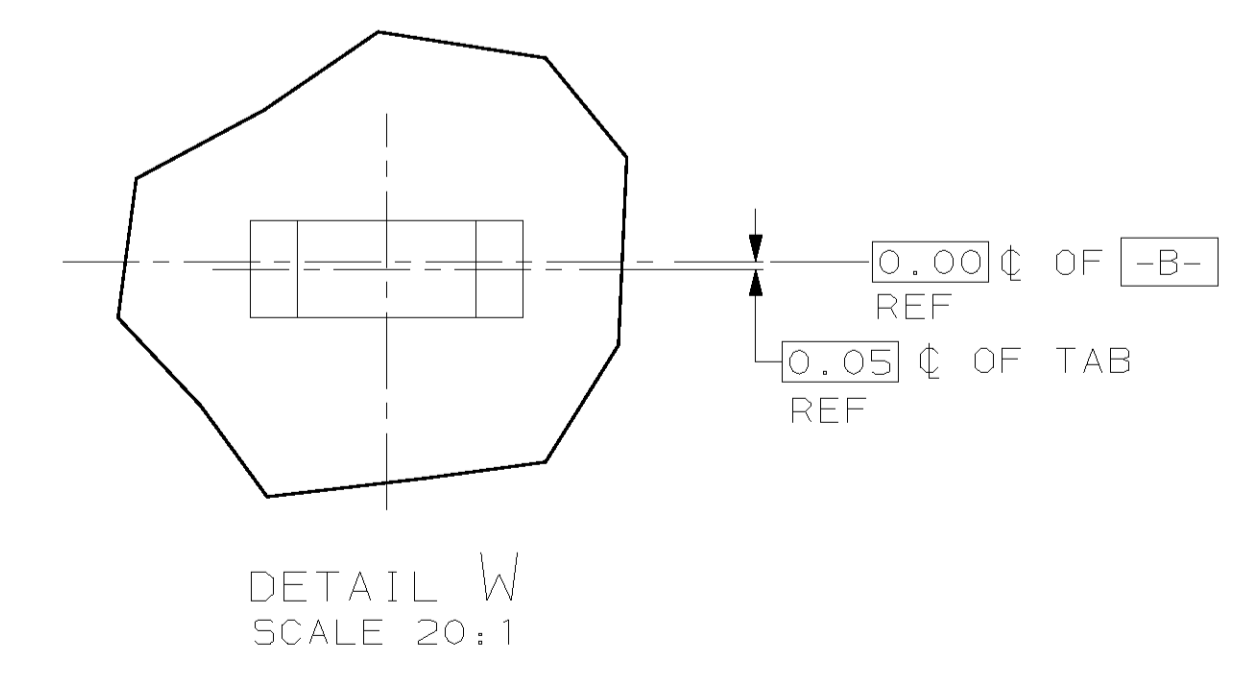
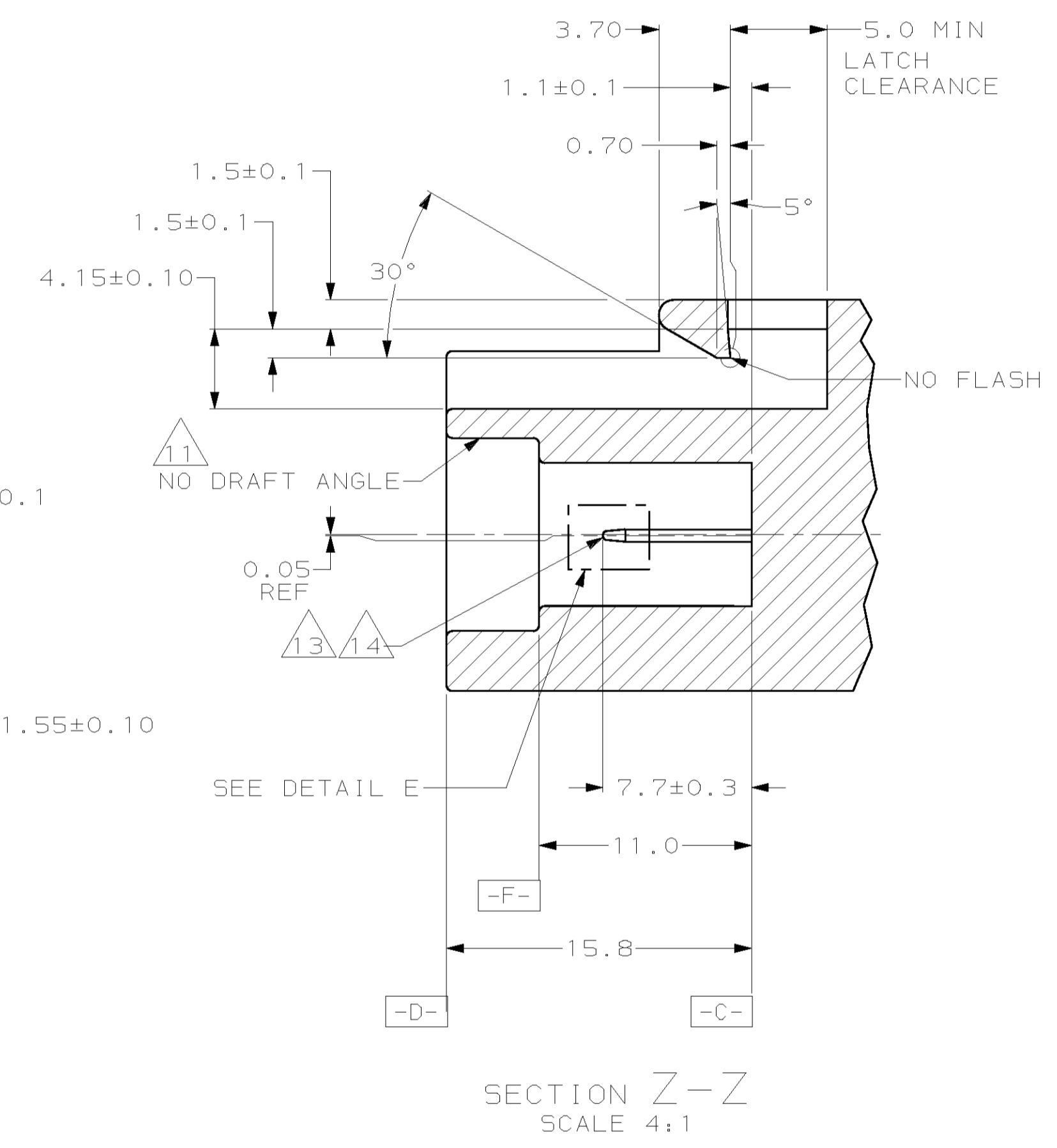
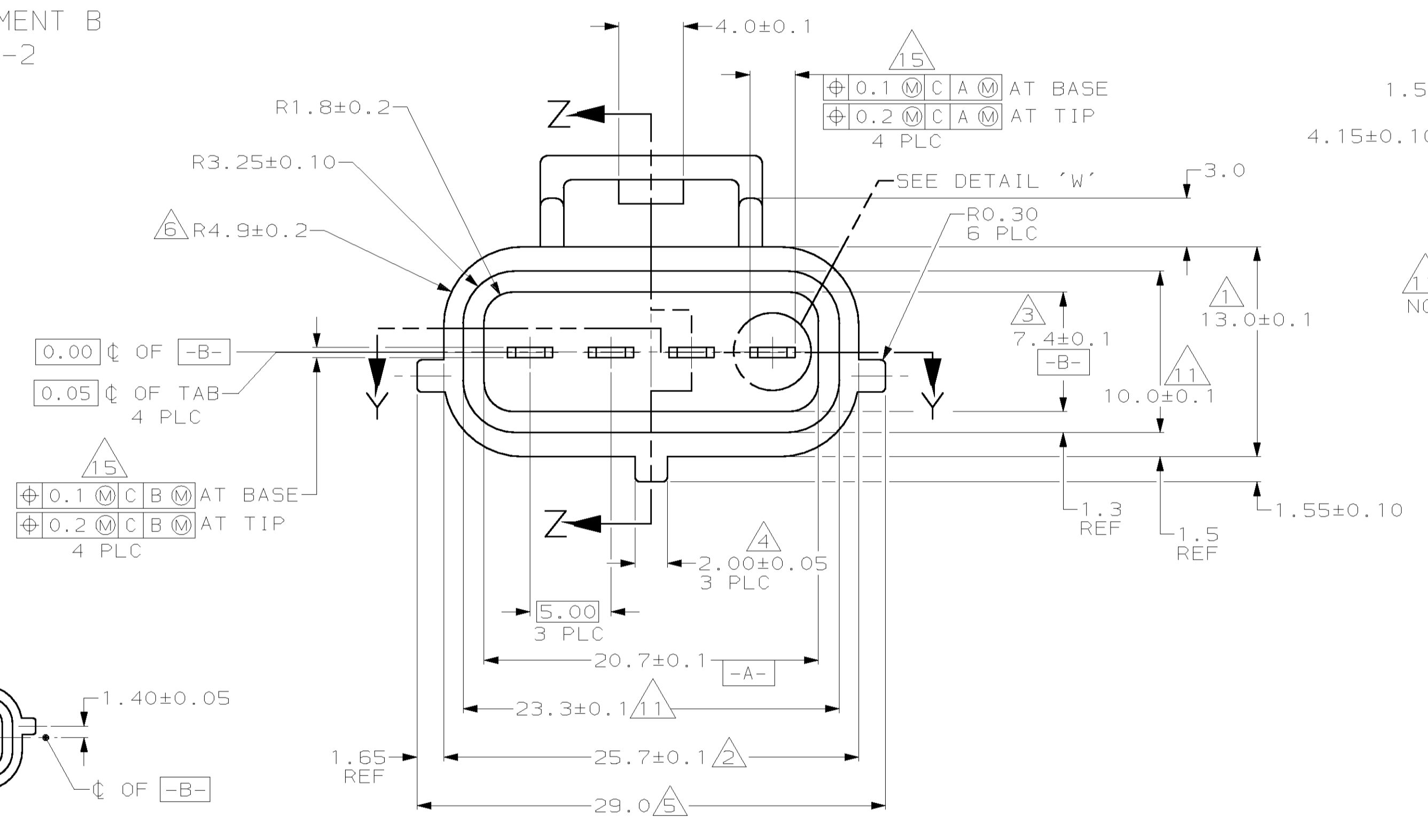

DESCRIPTION	PART NUMBER
AS SHOWN EXCEPT W/KEYING D	99-4072-038-4
AS SHOWN EXCEPT W/KEYING C	99-4072-038-3
AS SHOWN EXCEPT W/KEYING B	99-4072-038-2
AS SHOWN W/KEYING A	99-4072-038-1

DIMENSIONS:		TOLERANCES UNLESS OTHERWISE SPECIFIED:		MATERIAL:		FINISH:	
mm		0 PLC	±	APPROPRIATE MATERIAL FOR INDIVIDUAL APPLICATION			
		1 PLC	±0.15				
		2 PLC	±0.15				
		3 PLC	±				
		4 PLC	±				
		ANGLES	±1°				

DESCRIPTION	PART NUMBER
AS SHOWN EXCEPT W/KEYING D	99-4072-038-4
AS SHOWN EXCEPT W/KEYING C	99-4072-038-3
AS SHOWN EXCEPT W/KEYING B	99-4072-038-2
AS SHOWN W/KEYING A	99-4072-038-1

DATE	BY	CHK	APP'D	REV
04JUN99	YEAGER			
10JAN99	KUNKLE			
10JUN99	KUNKLE			

SIZE	CAGE CODE	DRAWING NO.
A1	00779	99-4072-038

SCALE	SHEET	OF	REV
4:1	11	1	0