

THIS DRAWING IS UNPUBLISHED. RELEASED FOR PUBLICATION 2005
 © COPYRIGHT 2005 BY TYCO ELECTRONICS CORPORATION. ALL RIGHTS RESERVED.

LOC	DIST	REVISIONS				
P	LTR	DESCRIPTION	DATE	DWN	APVD	
A1	-	B	ECR-09-005315	05MAR2009	witt	-

ERGOCRIMP DIE SET FOR MCON 2.8LL TERMINALS / 0,5-1,0 mm²

Ergocrimp Matrize als Ersatzteil erhaeltlich
 PN 9-1579021-1
 Ergocrimp die set as spare part available
 PN 9-1579021-1

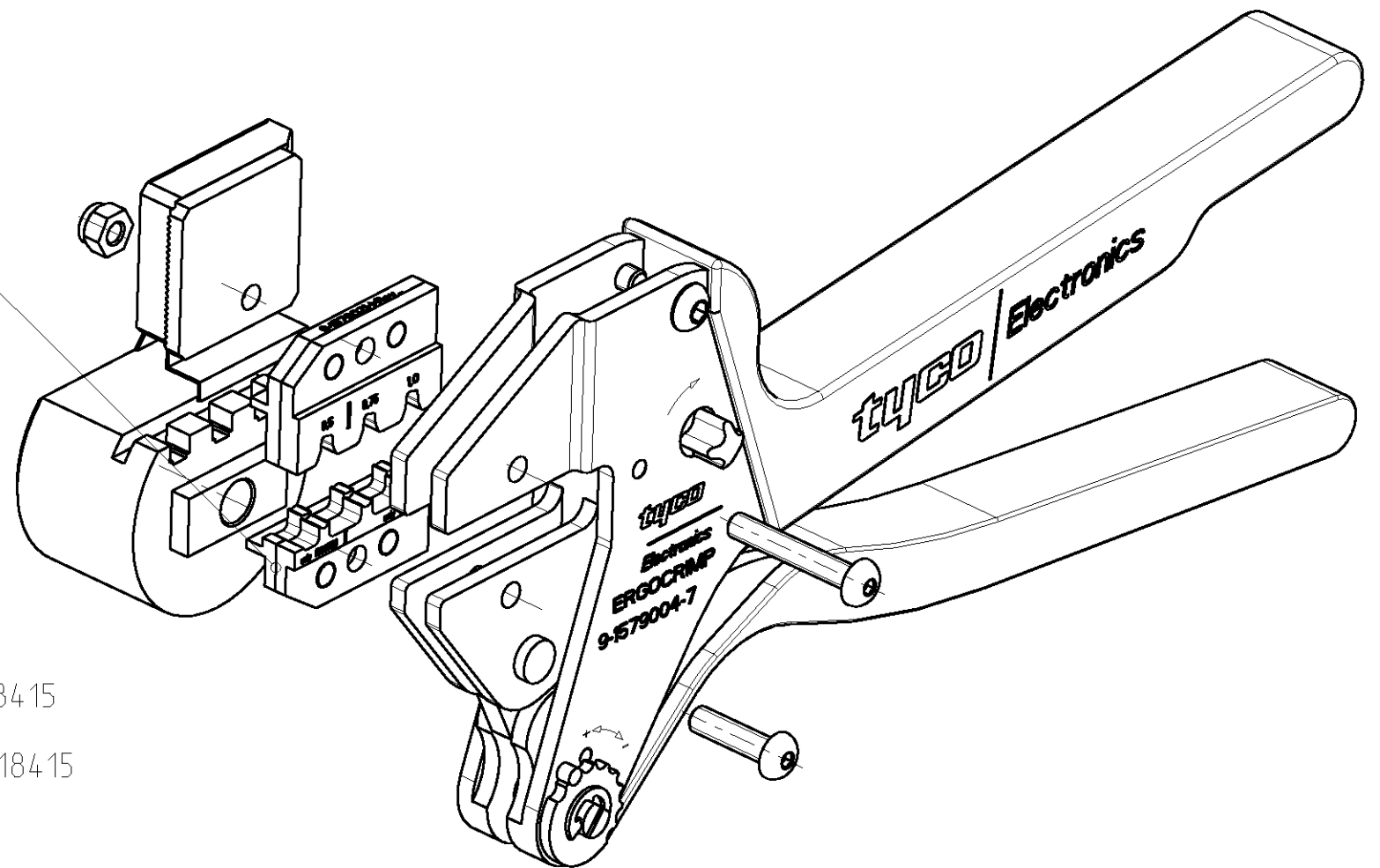

Einzelzeile der Ergocrimp Matrize bestellbar. Siehe Zeichnung PN 9-1579021-1
 Spare parts of the Ergocrimp die set available. See drawing PN 9-1579021-1

Handzange mit Matrize zusammengebaut und mit Bedienungsanleitung 411-18415
 im Karton verpackt
 Hand tool assembled with die set and packed with instruction sheet 411-18415
 in a cardboard

Kontakt	DGB (mm ²)	Drahtcrimp / Wire Crimp	Isolationscrimp / Insulationcrimp	Isol.Ø	Betriebsanl. / Instr. Sheet
1563720	0,50	1,08 ±0,03	1,78	2,4 ±0,1	411-18415
1719839	0,75	1,25 ±0,05	2,03	2,6 ±0,1	
	1,00	1,35 ±0,05		2,8 ±0,1	

<small>THIS DRAWING IS A CONTROLLED DOCUMENT FOR TYCO ELECTRONICS CORPORATION IT IS SUBJECT TO CHANGE AND THE CONTROLLING ENGINEERING ORGANIZATION SHOULD BE CONTACTED FOR THE LATEST REVISION.</small>		DWN Ch.Witt 03MAY2007 CHK - APVD - PRODUCT SPEC - APPLICATION SPEC - WEIGHT 750 g		tyco Electronics tyco Electronics AMP GmbH D - 64625 Bensheim NAME ERGOCRIMP HAND TOOL FOR MCON 2.8LL / 0,5-1,0 mm ²	
DIMENSIONS: mm 		TOLERANCES UNLESS OTHERWISE SPECIFIED: 0 PLC ± 1 PLC ± 2 PLC ± 3 PLC ± 4 PLC ± ANGLES ±1° MATERIAL - FINISH -		SIZE A3 CAGE CODE 00779 DRAWING NO C-9-1579004-7 RESTRICTED TO -	
CUSTOMER DRAWING			SCALE 1:1 SHEET 1 OF 1 REV B		