



85BC

SPECIFICATIONS

- ◆ **Low Cost**
- ◆ **316L Stainless Steel**
- ◆ **13mm Diameter Package**
- ◆ **0 - 100mV Output**
- ◆ **Gage and Absolute**
- ◆ **Wide Compensated Temperature Range**

The 85BC is a 13mm small profile, media compatible, piezoresistive silicon pressure sensor packaged in a 316L stainless steel housing. The 85BC is offered in a weldable package or with a variety of threaded fittings such as 1/4 and 1/8NPT, 1/4BSP as well as custom process fittings.

The 85BC is a low cost unit designed without a header for OEM applications where compatibility with corrosive media is required. The sensing package utilizes silicon oil to transfer pressure from the 316L stainless steel diaphragm to the sensing element. A ceramic substrate is attached to the package that contains laser-trimmed resistors for temperature compensation and offset correction. An additional laser trimmed resistor is included which can be used to adjust an external differential amplifier and provide span interchangeability to within $\pm 1\%$.

Please refer to the 85 uncompensated and constant voltage datasheets for more information on different features of the 85.

FEATURES

- ◆ **Weldable/Threaded Process Fittings**
- ◆ **-20°C to +85°C Compensated Temperature**
- ◆ **1.0% Interchangeable Span (provided by gain set resistor)**
- ◆ **Solid State Reliability**
- ◆ **$\pm 0.3\%$ Pressure Non Linearity**

APPLICATIONS

- ◆ **Medical Instruments**
- ◆ **Process Control**
- ◆ **Fresh & Waste Water Measurements**
- ◆ **Partial Vacuum Gas Measurement**
- ◆ **Pressure Transmitters**
- ◆ **Tank Level Systems (RV & Industrial)**

STANDARD RANGES

Range (psi)	Gage	Range (Bar)	Absolute
0 to 015	◆	0 to 001	◆
0 to 030	◆	0 to 002	◆
0 to 050	◆	0 to 004	◆
0 to 100	◆	0 to 007	◆
		0 to 012	◆
		0 to 018	◆
0 to 300	◆	0 to 028	◆

PERFORMANCE SPECIFICATIONS

Supply Current: 1.5mA

Ambient Temperature: 25°C (unless otherwise specified)

PARAMETERS	MIN	TYP	MAX	UNITS	NOTES
Span	75	100	150	mV	1, 2
Zero Pressure Output, Offset	-1	0	+1	mV	2
Pressure Non-Linearity	-0.3		0.3	%Span	3
Pressure Hysteresis	-0.2		0.2	%Span	
Repeatability		±0.02		%Span	
Input Resistance	2.0	3.5	5.8	kΩ	
Output Resistance	3.0		25.0	kΩ	
Temperature Error – Span	-2.0		2.0	%Span	4
Temperature Error – Zero	-2.0		2.0	%Span	4
Thermal Hysteresis – Span	-0.25	±0.05	0.25	%Span	4
Thermal Hysteresis – Offset	-0.25	±0.05	0.25	%Span	4
Long Term Stability – Span		±0.10		%Span/Year	
Long Term Stability – Offset		±0.25		%Span/Year	
Supply Current	0.5	1.5	2.0	mA	5
Output Load Resistance	5			MΩ	6
Insulation Resistance (50Vdc)	50			MΩ	7
Output Noise (10Hz to 1kHz)		1.0		μV p-p	
Response Time (10% to 90%)		0.1		ms	
Pressure Overload			2X	Rated	8
Pressure Burst			3X	Rated	9
Compensated Temperature	-20		+85	°C	10
Operating Temperature	-40		+105	°C	10
Storage Temperature	-50		+105	°C	10
Media – Pressure Port	Liquids and Gases compatible with 316/316L Stainless Steel				

Notes

- For amplified output circuits, 3.012V ±1% interchangeability with gain set resistor. See application schematic.
- Measured at vacuum for absolute (A), ambient for gage (G).
- Best fit straight line.
- Over the compensated temperature range with respect to 25°C.
- Guarantees output/input ratiometricity.
- Load resistance to reduce measurement errors due to output loading.
- Between case and sensing element.
- 2X or 500psi, whichever is less. The maximum pressure that can be applied without changing the transducer's performance or accuracy.
- 3X or 600psi, whichever is less. The maximum pressure that can be applied to a transducer without rupture of either the sensing element or transducer.
- Maximum temperature range for product with standard cable and connector is -20°C to +105°C.

Additional Notes

- Direct mechanical contact with diaphragm is prohibited. Diaphragm surface must remain free of defects (scratches, punctures, dents, fingerprints, etc.) for device to operate properly. Caution is advised when handling parts with exposed diaphragms. Use protective cap whenever devices are not in use.
- Standard gage units are not recommended for vacuum applications.

DIMENSIONS

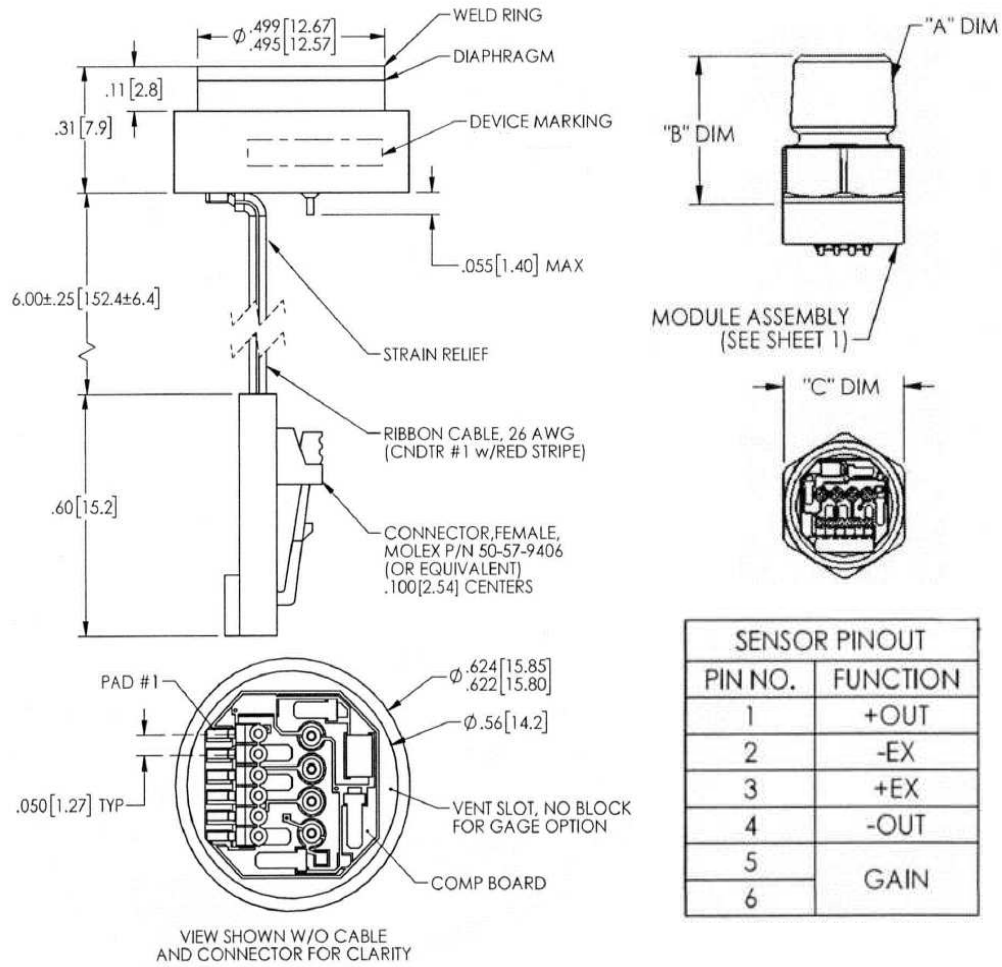

SENSOR PINOUT	
PIN NO.	FUNCTION
1	+OUT
2	-EX
3	+EX
4	-OUT
5	GAIN
6	

FITTING DIMENSIONS				
FITTING TYPE	MEAS PART NO.	"A" DIM	"B" DIM	"C" DIM
1	IC-7050	1/4-18 NPT	.99 [25.1]	7/8 [22.2] HEX
2	IC-7049	1/8-27 NPT	.96 [24.4]	7/8 [22.2] HEX
3	IC-7048	7/16-20 UNF	.81 [20.6]	7/8 [22.2] HEX
4	IC-6754	1/4-18 NPT	.73 [18.5]	5/8 [15.9] HEX
5	IC-5010	1/4-19 BSP	.76 [19.3]	3/4 [19.0] HEX
8	IC-6800	1/8-27 NPT	.60 [15.2]	5/8 [15.9] HEX
9	IC-7124	1/4-19 BSP	.94 [23.9]	7/8 [22.2] HEX

NOTE : FTG TYPE '4' ASSEMBLY SHOWN
 ALL DIMS ARE FOR REFERENCE

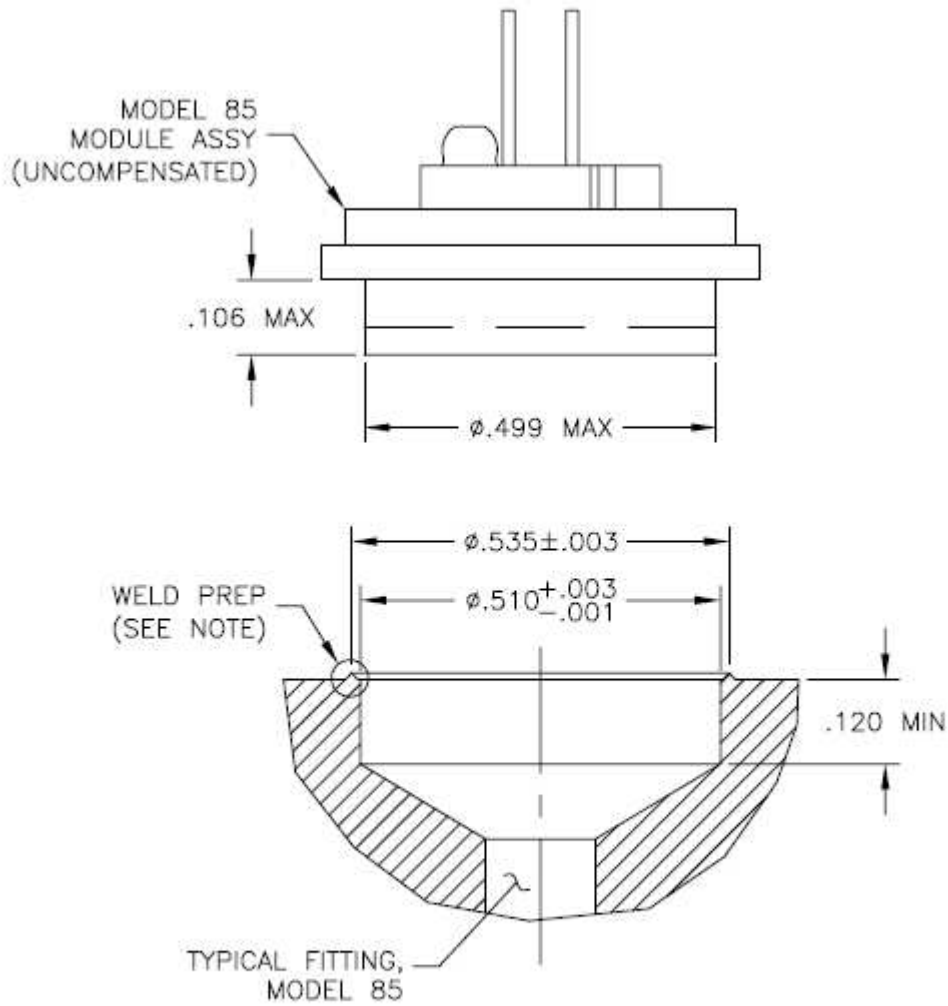

NOTE: WELD PREP SHOWN IS FOR RESISTANCE WELD. ACTUAL GEOMETRY VARIES PER CUSTOMER REQUIREMENTS.

APPLICATION SCHEMATIC

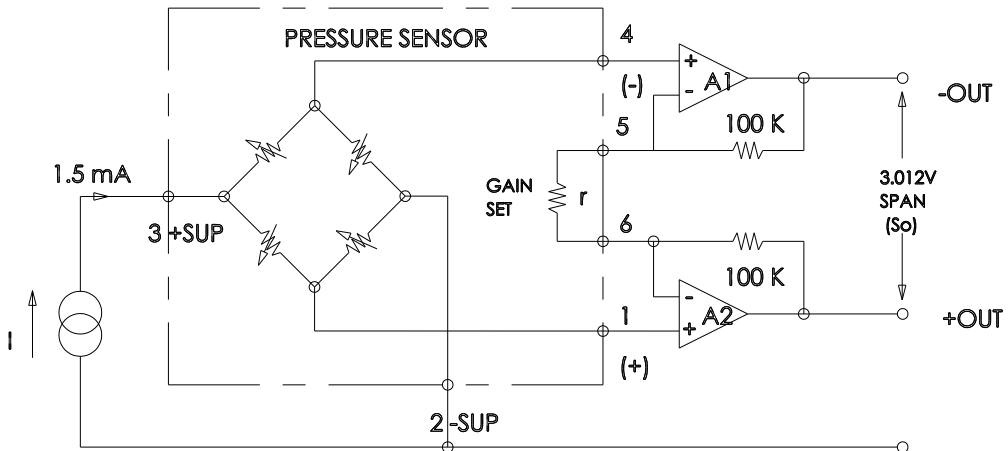

ORDERING INFORMATION

85BC - 100PG - 5 C

Pressure Range and Type	
015PG	001BA
030PG	002BA
050PG	004BA
100PG	007BA
300PG	012BA
	018BA
	028BA

Fitting Type	
0	No Fitting, Weldable
1	1/4NPT, 7/8 Hex
2	1/8NPT, 7/8 Hex
3	7/16UNF, 7/8 Hex
4	1/4NPT, 5/8 Hex
5	1/5 BSP, 3/4 Hex
8	1/8 NPT, 5/8 Hex
9	1/4BSP, 7/8 Hex

Electrical	
P	Solder Pads
R	Ribbon cable
C	Cable w/ Connector

NORTH AMERICA

Measurement Specialties, Inc.,
a TE Connectivity Company
Tel: 800-522-6752
Email: customercare.frmr@te.com

EUROPE

Measurement Specialties (Europe), Ltd.,
a TE Connectivity Company
Tel: +31 73 624 6999
Email: customercare.lcsb@te.com

ASIA

Measurement Specialties (China), Ltd.,
a TE Connectivity Company
Tel: 0400-820-6015
Email: customercare.shzn@te.com

TE.com/sensorsolutions

Measurement Specialties, Inc., a TE Connectivity company.

Measurement Specialties, TE Connectivity, TE Connectivity (logo) and EVERY CONNECTION COUNTS are trademarks. All other logos, products and/or company names referred to herein might be trademarks of their respective owners.

The information given herein, including drawings, illustrations and schematics which are intended for illustration purposes only, is believed to be reliable. However, TE Connectivity makes no warranties as to its accuracy or completeness and disclaims any liability in connection with its use. TE Connectivity's obligations shall only be as set forth in TE Connectivity's Standard Terms and Conditions of Sale for this product and in no case will TE Connectivity be liable for any incidental, indirect or consequential damages arising out of the sale, resale, use or misuse of the product. Users of TE Connectivity products should make their own evaluation to determine the suitability of each such product for the specific application.

© 2015 TE Connectivity Ltd. family of companies All Rights Reserved.