

REVISIONS				
P	LTN	DESCRIPTION	DATE	APVD
A15		REVISED PER ECO-20-004256	25MAR2020	JM DS
A16		REVISED PER PCN E-20-016603	24NOV2020	PN DS
B		REVISED PER ECR-23-167643	10MAR2023	DK CB
B1		REVISED PER ECR-246938	13SEP2024	DK CB

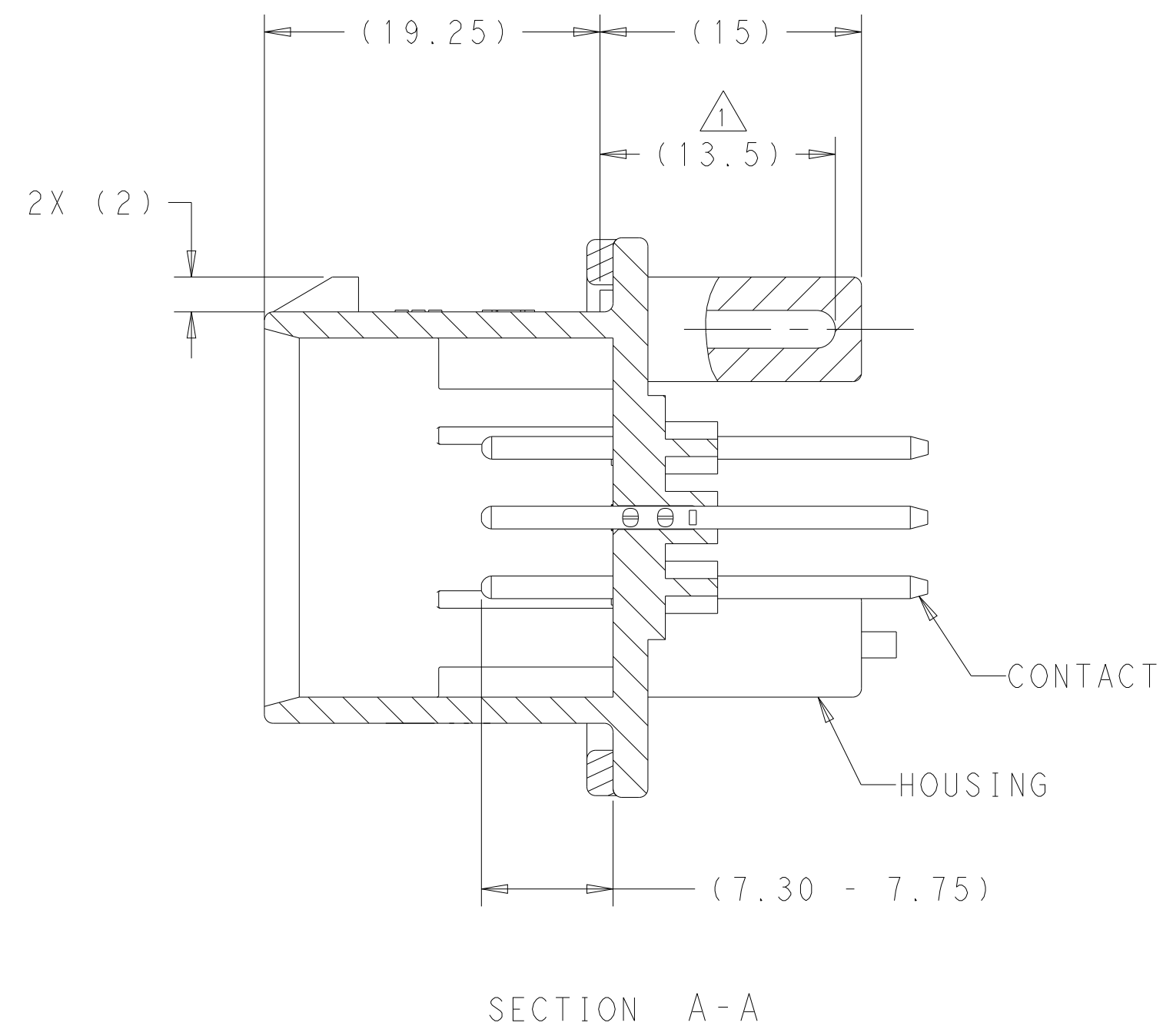
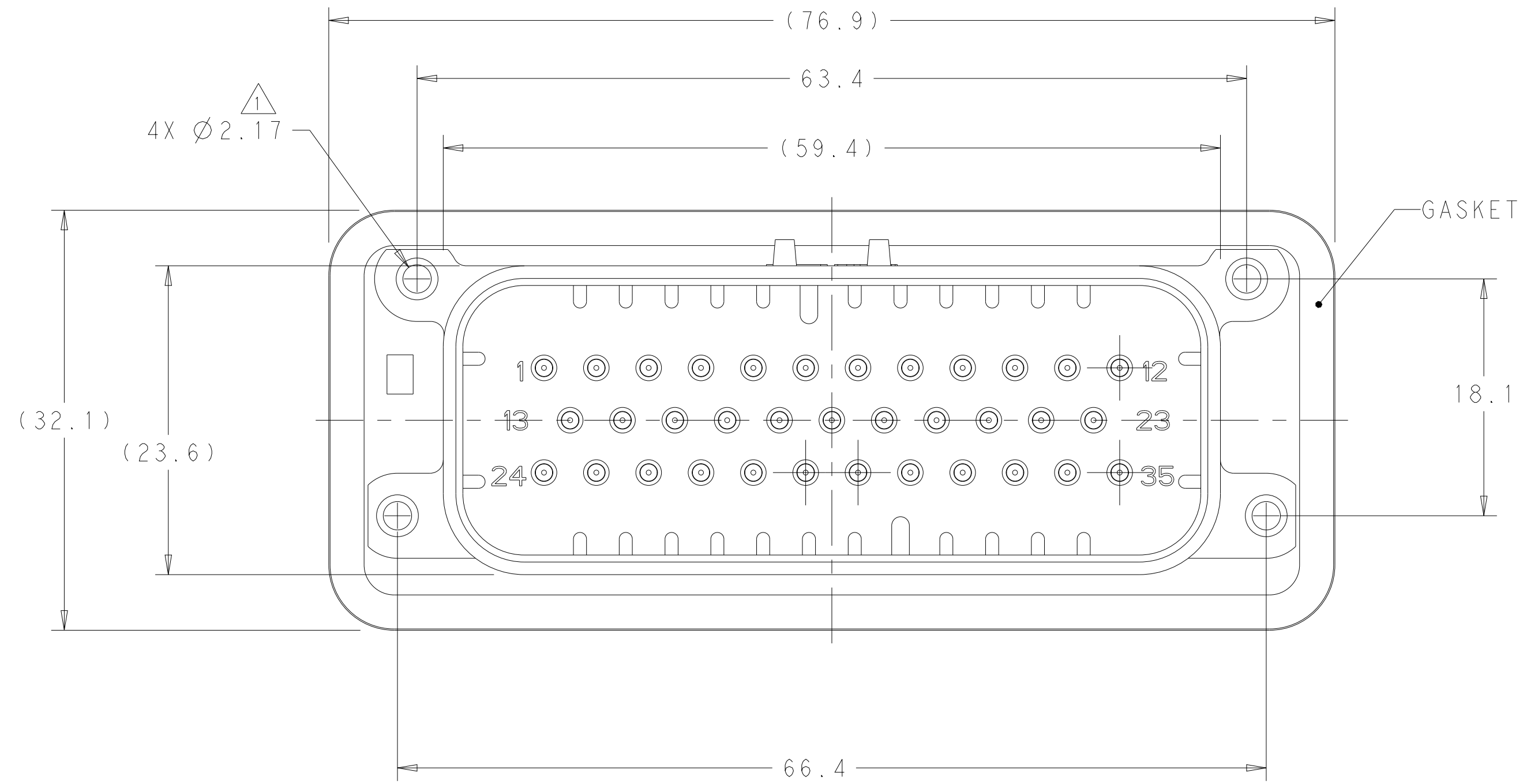

1 SUGGESTED MOUNTING SCREW SIZE IS Ø2.50mm [APPROX. 0.099 INCH] SELF TAPPING THREAD FORMING SCREW, SUCH AS DELTA PT, TO BE DRIVEN AT 0.6-0.8 N-m. THE CUSTOMER MUST TEST THE SCREW SIZE AND TYPE IN ORDER TO VERIFY THEIR SELECTION BEFORE USE IN APPLICATION

TO VALIDATE HEADER MOUNTING PERFORMANCE, TE CONNECTIVITY WILL CONTINUE TO UTILIZE THE FOLLOWING TORQUE VALIDATION PROCESS ACCORDING TO APPLICATION SPEC 114-16016:
 MOUNTING PANEL THICKNESS - 4.75 +/- 0.15mm
 SCREW - 2.5X12mm DELTA PT

CUSTOMERS MAY VALIDATE OTHER SCREW SIZES AND TYPES AT THEIR OWN DISCRETION

2 DATE CODE IN THIS LOCATION USING 5 DIGIT CODE
 FIRST 2 DIGITS = YEAR, SECOND 2 DIGITS = WEEK
 LAST DIGIT = DAY.

3 MATERIALS: HEADER HOUSING - GLASS FILLED PBT
 PINS - TIN OR GOLD PLATED BRASS
 GASKET - SILICONE

4 HOUSING COLORS ARE MECHANICALLY KEYS TO MATE ONLY WITH IDENTICALLY COLORED PLUG ASSEMBLIES.

5. HEADER MATES TO PLUG ASSEMBLY 776164 WHICH USES REELED TERMINAL 770520 OR LOOSE PIECE TERMINAL 770854

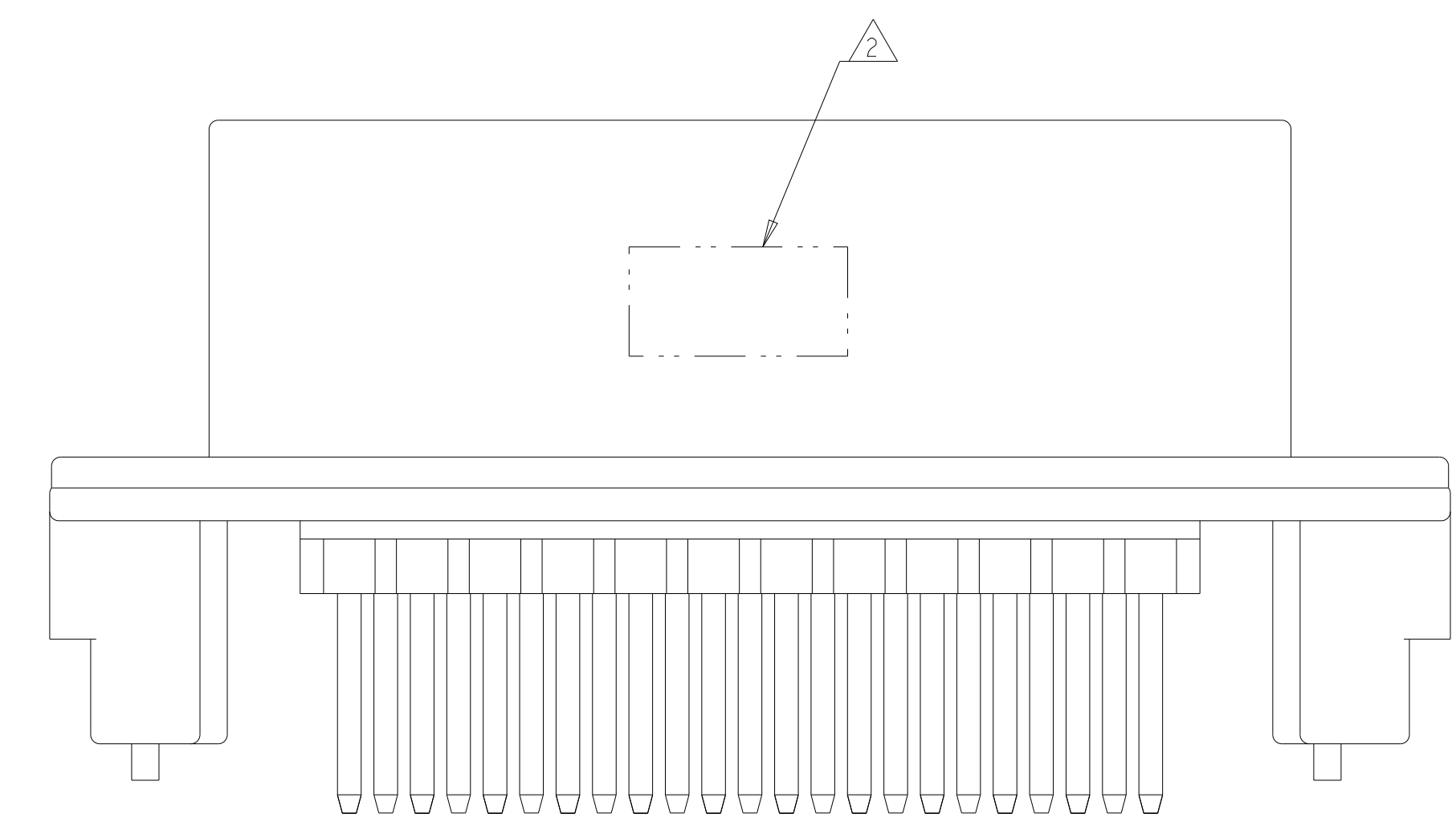

776231-1 & 1-776231-1 SHOWN

ORANGE	GOLD	1-776231-6
BLUE	GOLD	1-776231-5
GRAY	GOLD	1-776231-4
NATURAL	GOLD	1-776231-2
BLACK	GOLD	1-776231-1
BLUE	TIN	776231-5
GRAY	TIN	776231-4
NATURAL	TIN	776231-2
BLACK	TIN	776231-1
HEADER COLOR	PLATING	PART NUMBER

THIS DRAWING IS A CONTROLLED DOCUMENT.		OWN D. STRAUSSER 05MAR2010		
DIMENSIONS: mm		CHK D. STRAUSSER 22MAR2010		
TOLERANCES UNLESS OTHERWISE SPECIFIED:		APVD D. STRAUSSER 27APR2010	NAME ASSEMBLY, HEADER, 35 POSITION, VERTICAL, AMPSEAL WITH FLANGE SEAL	
0 PLC ±0.2	1 PLC ±0.2	PRODUCT SPEC 108-1329	SIZE 114-16016	RESTRICTED TO
2 PLC ±	3 PLC ±	APPLICATION SPEC	WEIGHT 40.29g	
4 PLC ±	ANGLES ±	FINISH	CUSTOMER DRAWING	SCALE 3:1 SHEET 1 OF 2 REV B1

REVISIONS				
P.	LTH.	DESCRIPTION	DATE	APVD.
-	-	SEE SHEET 1	-	-

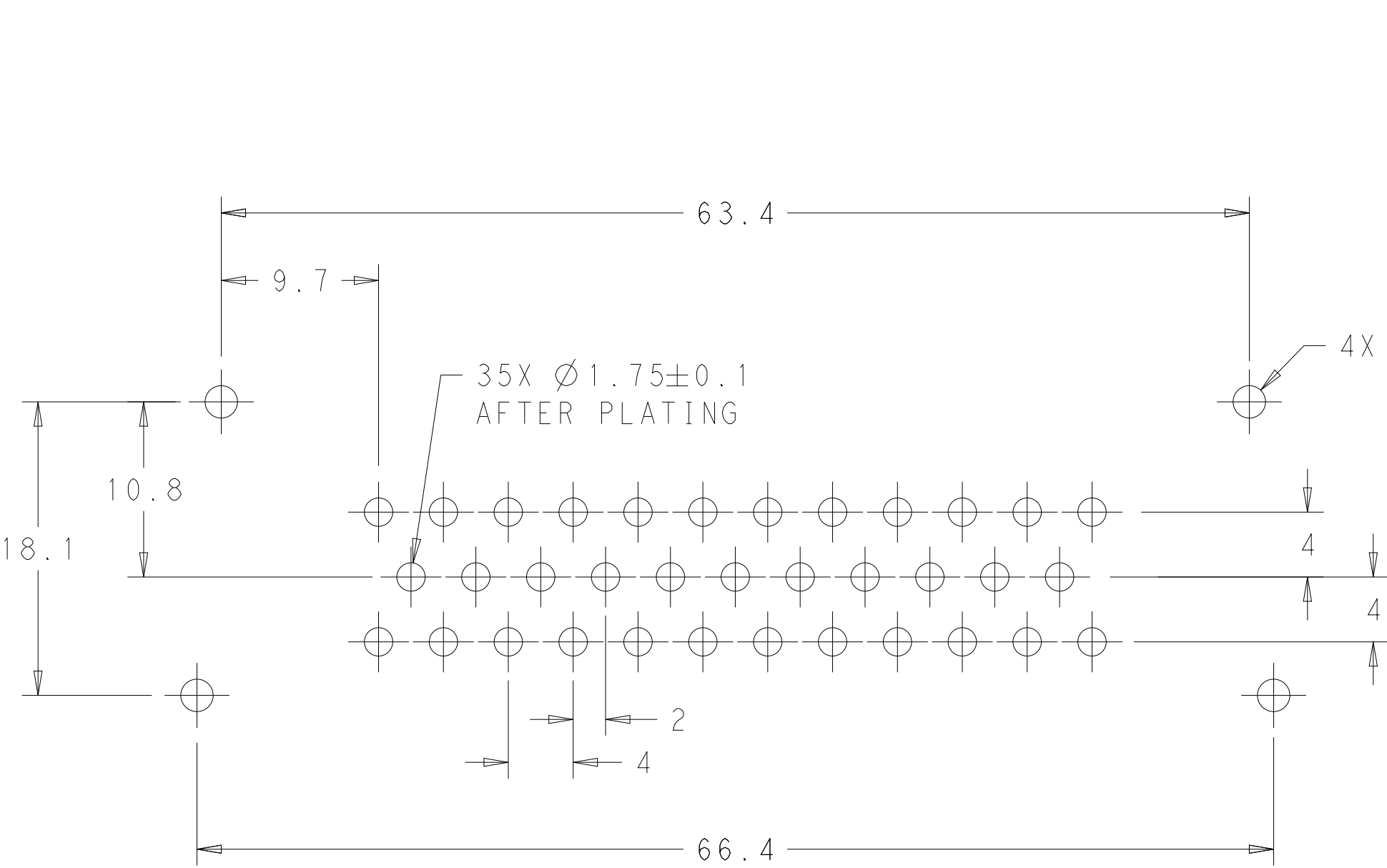

RECOMMENDED P.C. BOARD LAYOUT FOR 1.57 THICK P.C. BOARD

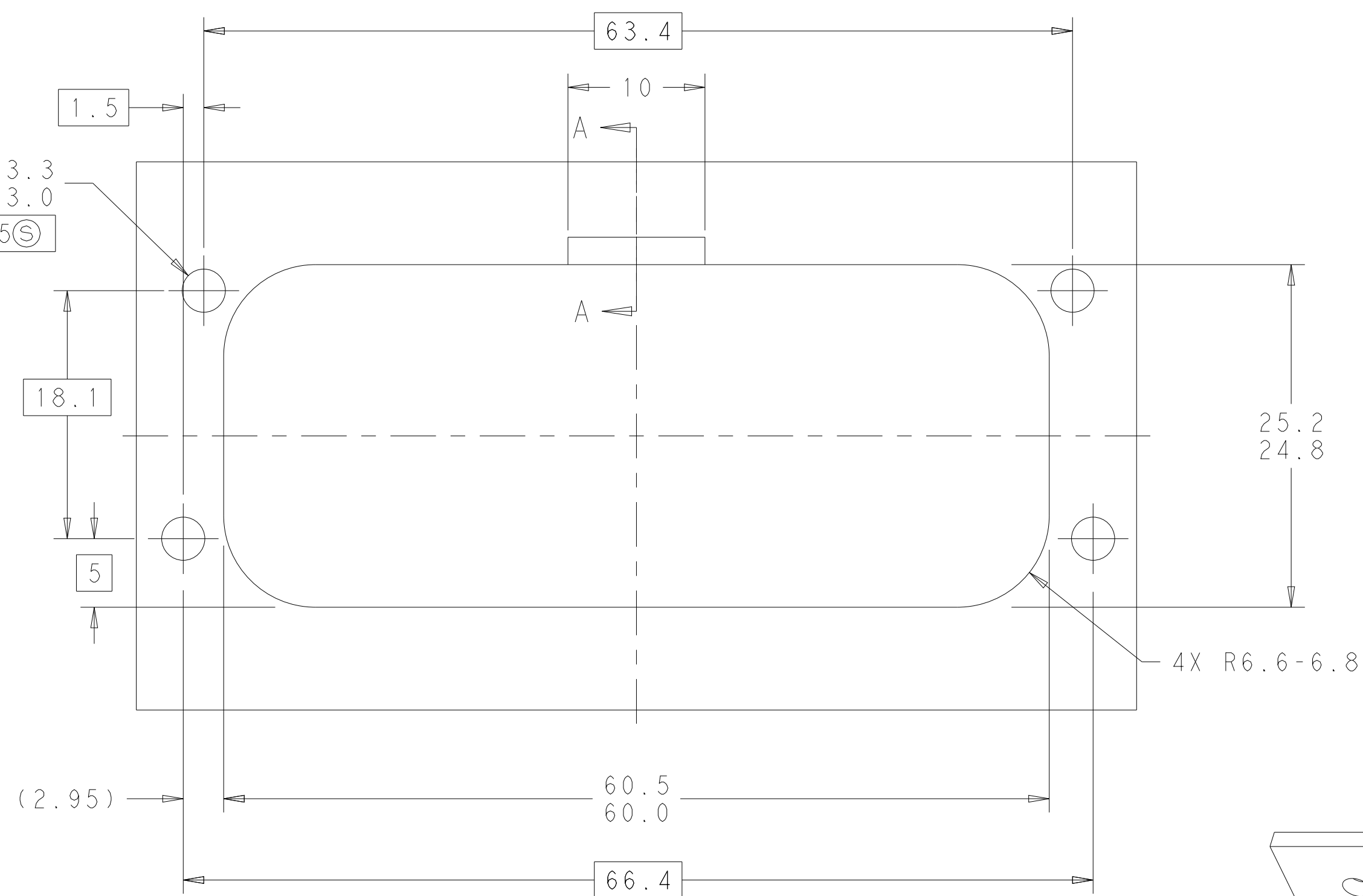

RECOMMENDED MOUNTING HOLE LAYOUT FOR 5.0 MAX THICK PANEL

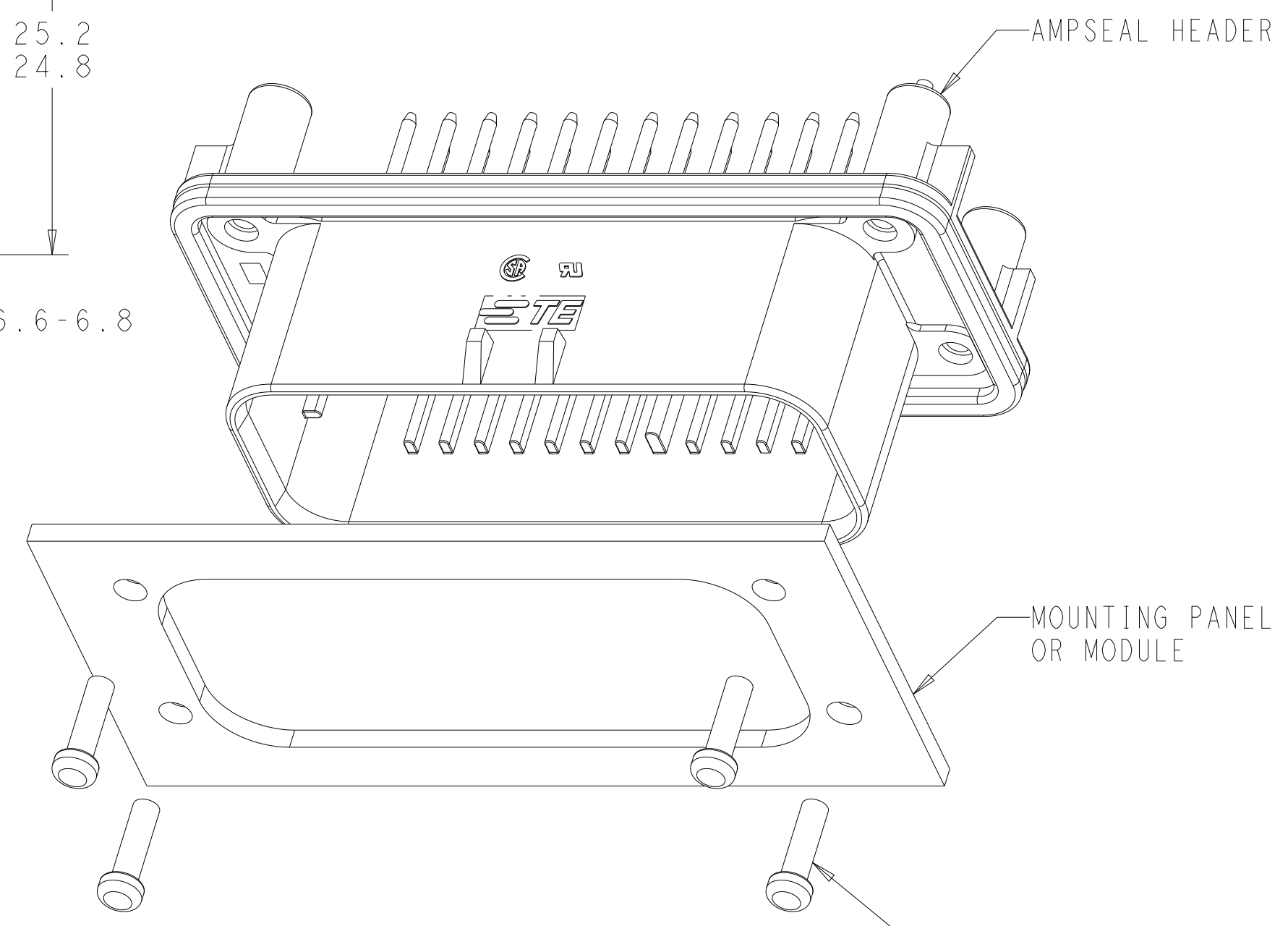

SCALE 2:1

MOUNTING SCREW (4)
TORQUE TO 0.6N-m TO 0.8N-m

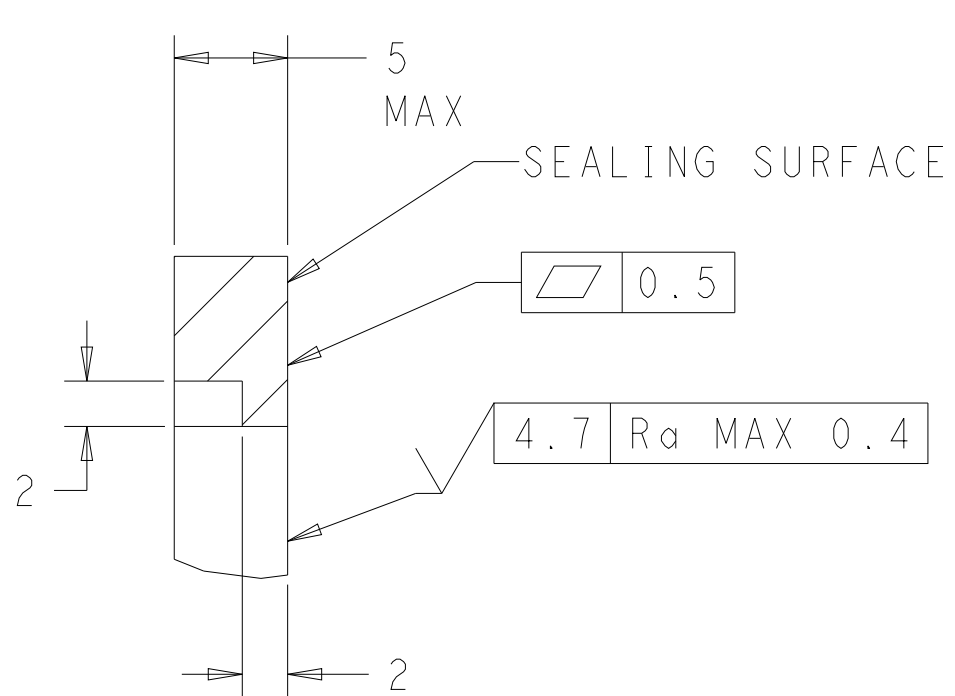

SECTION A-A
OPTIONAL CONSTRUCTION IF PANEL THICKNESS IS GREATER THAN 2.0

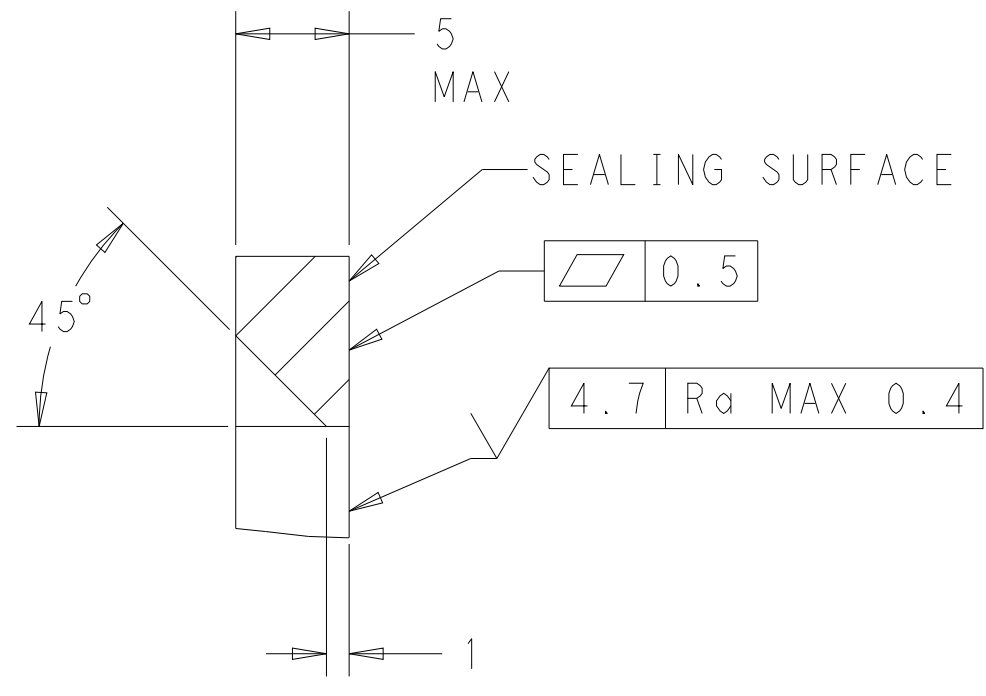

SECTION A-A
OPTIONAL CONSTRUCTION IF PANEL THICKNESS IS GREATER THAN 2.0

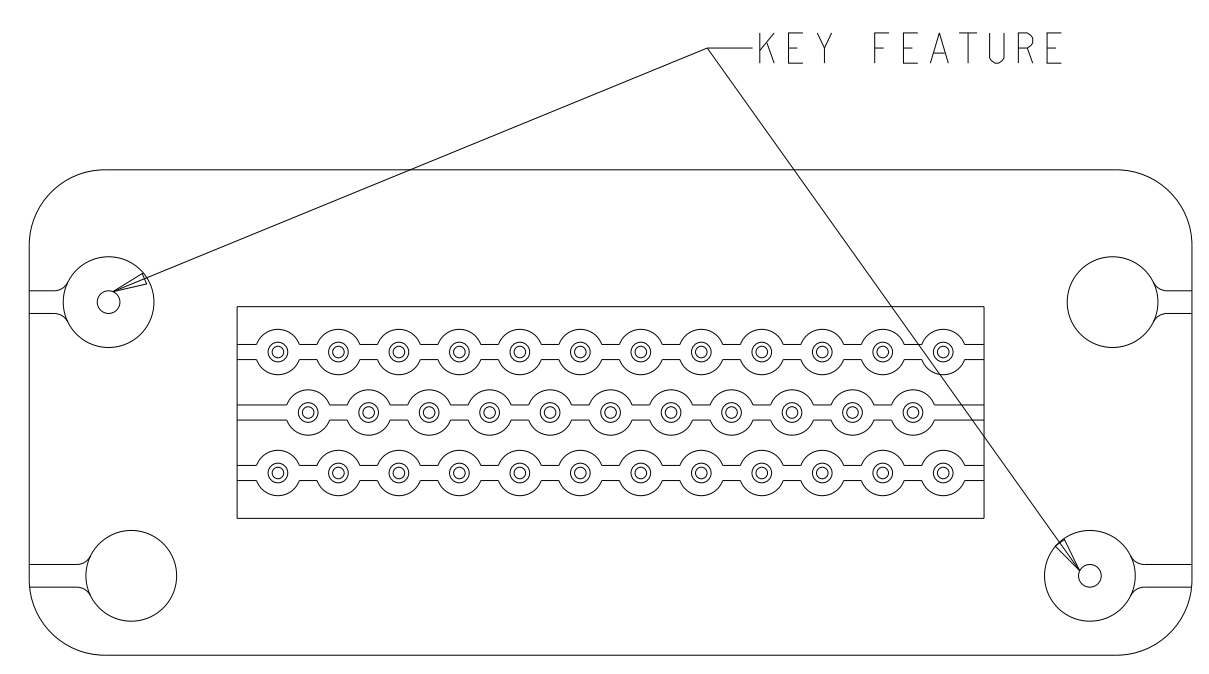

KEYING FOR 776231-1 1-776231-1, 776231-4, 1-776231-4 AND 1-776231-6
SCALE 2:1

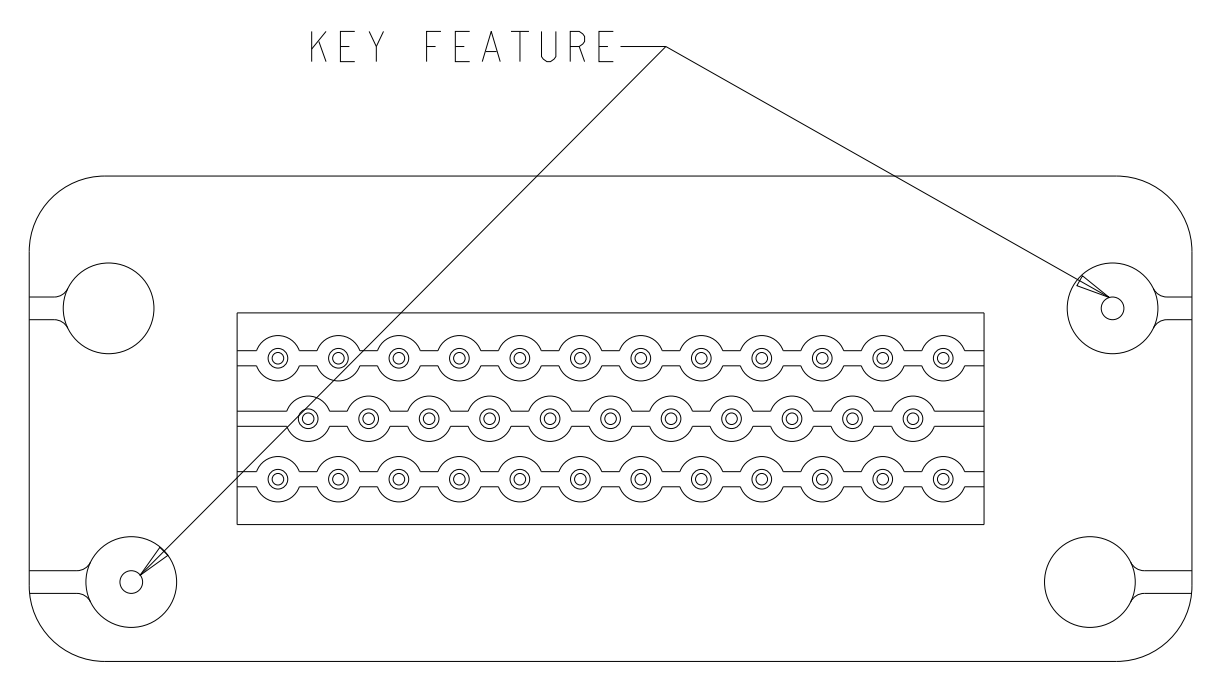

KEYING FOR 776231-2, 1-776231-2, 776231-5 AND 1-776231-5
SCALE 2:1

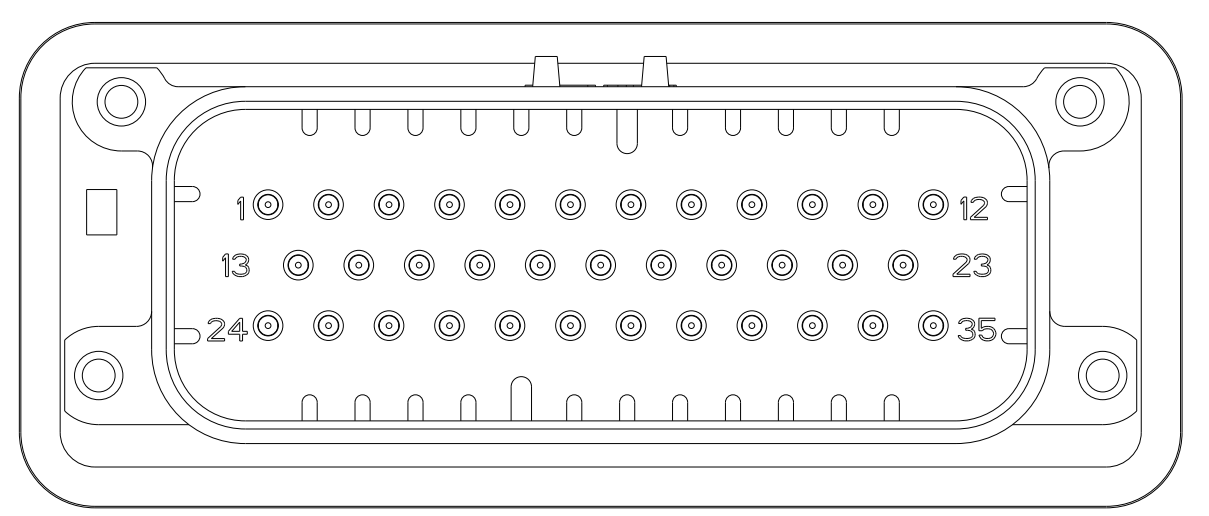

776231-2 & 1-776231-2
KEY LOCATION
SCALE 2:1

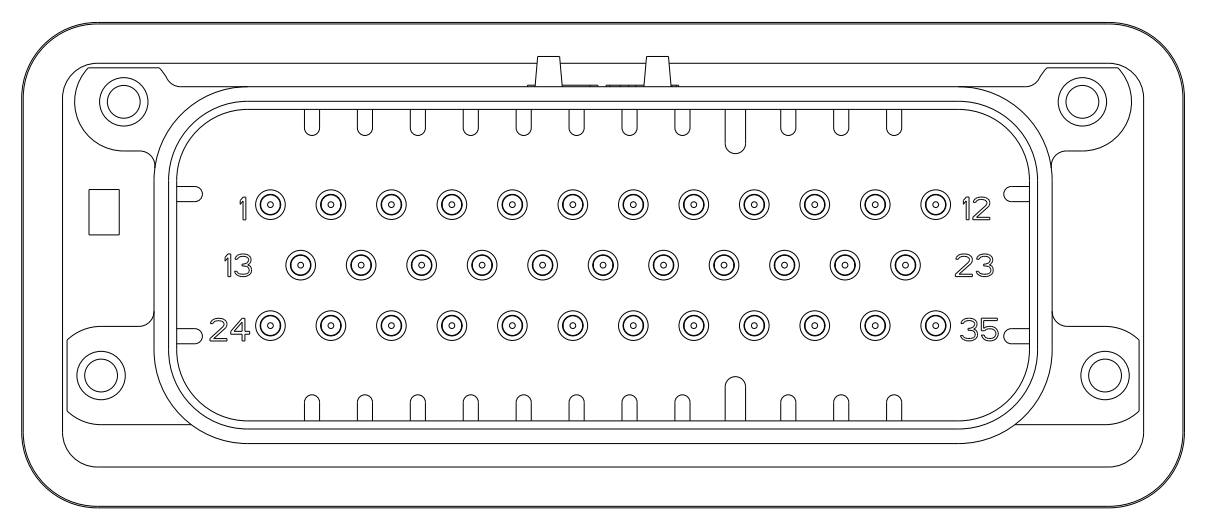

776231-4 & 1-776231-4
KEY LOCATION
SCALE 2:1

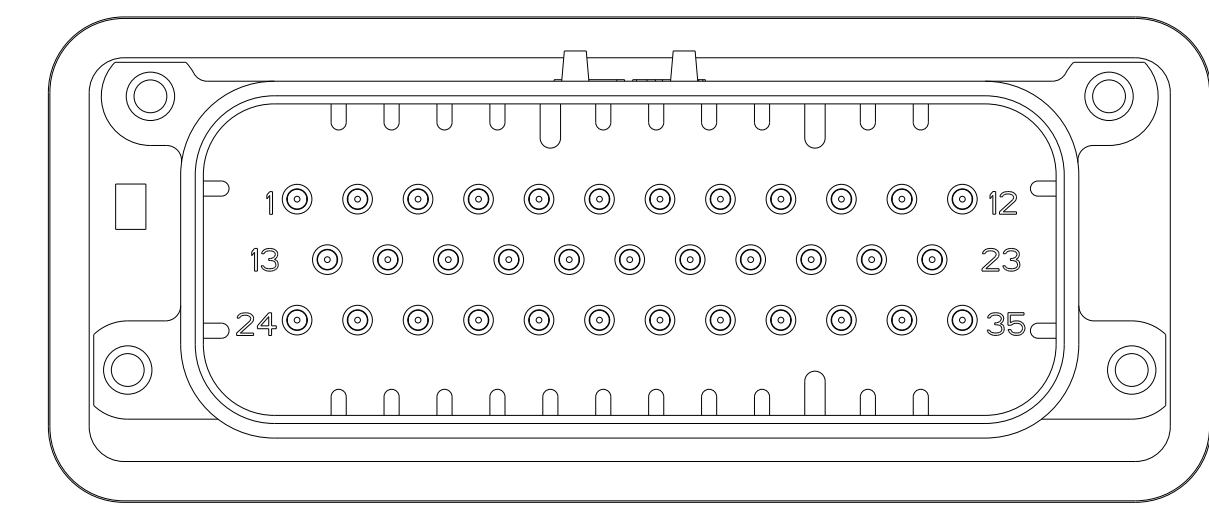

776231-5 & 1-776231-5
KEY LOCATION
SCALE 2:1

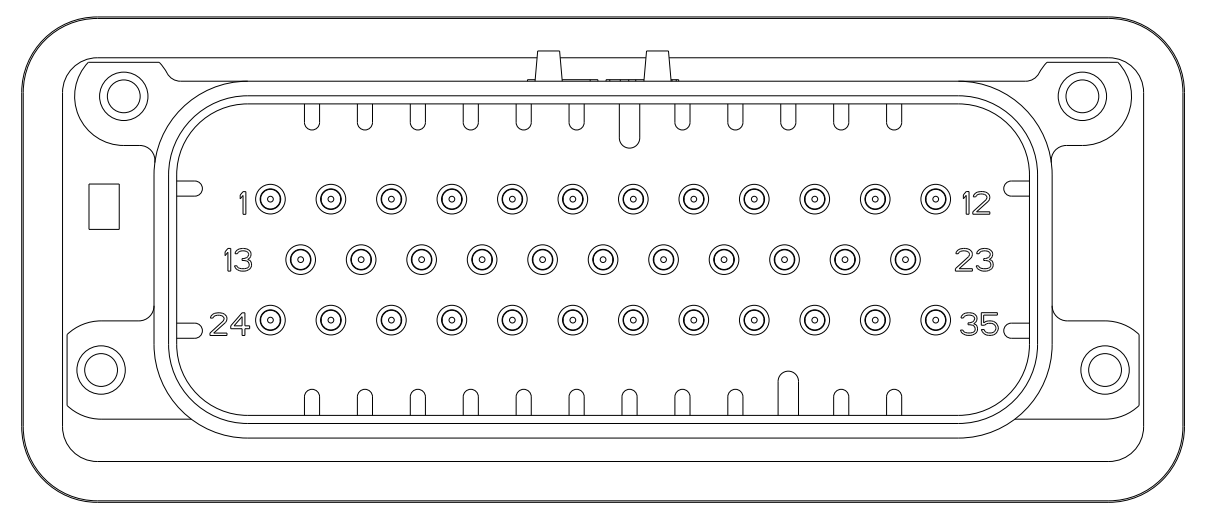

1-776231-6
KEY LOCATION
SCALE 2:1

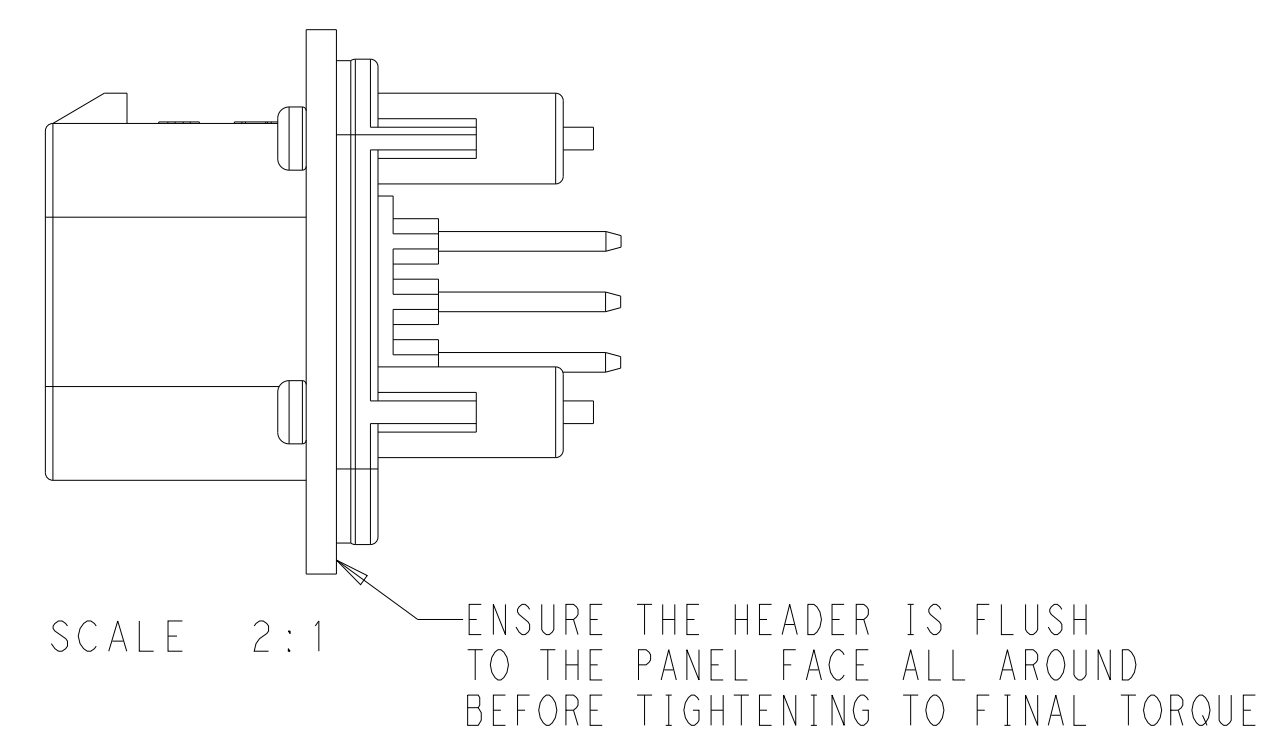

SCALE 2:1
ENSURE THE HEADER IS FLUSH TO THE PANEL FACE ALL AROUND BEFORE TIGHTENING TO FINAL TORQUE

THIS DRAWING IS A CONTROLLED DOCUMENT.		OWN: D. STRAUSSER 05MAR2010	TE Connectivity	
DIMENSIONS:		CHK: D. STRAUSSER 22MAR2010	NAME: ASSEMBLY, HEADER, 35 POSITION, VERTICAL, AMPSEAL WITH FLANGE SEAL	
mm	TOLERANCES UNLESS OTHERWISE SPECIFIED:	APVD: D. STRAUSSER 27APR2010	PRODUCT SPEC: 108-1329	RESTRICTED TO: -
0 PLC	±	APPLICATION SPEC: 114-16016	SIZE: A1	CAGE CODE: 00779
1 PLC	±0.2	WEIGHT: 40.29g	SCALE: 1:1	SHEET 2 OF 2
2 PLC	±	CUSTOMER DRAWING	REV: B1	
3 PLC	±			
4 PLC	±			
ANGLES	±			
FINISH	±			