

THIS DRAWING IS UNPUBLISHED. RELEASED FOR PUBLICATION, 19  
 © COPYRIGHT 19 BY AMP INCORPORATED. ALL INTERNATIONAL RIGHTS RESERVED.

LOC	DIST	P	F	REVISIONS				
G	14			ZONE	LTR	DESCRIPTION	DATE	APPD
					B	REV PER 0G3A-0568-02	16SEP02	JR/TM

**AMP**  
WIRE RANGE  
22-18 AWG  
STRANDED

**METRIC**  
DIMENSIONS LISTED IN mm [ INCHES ]

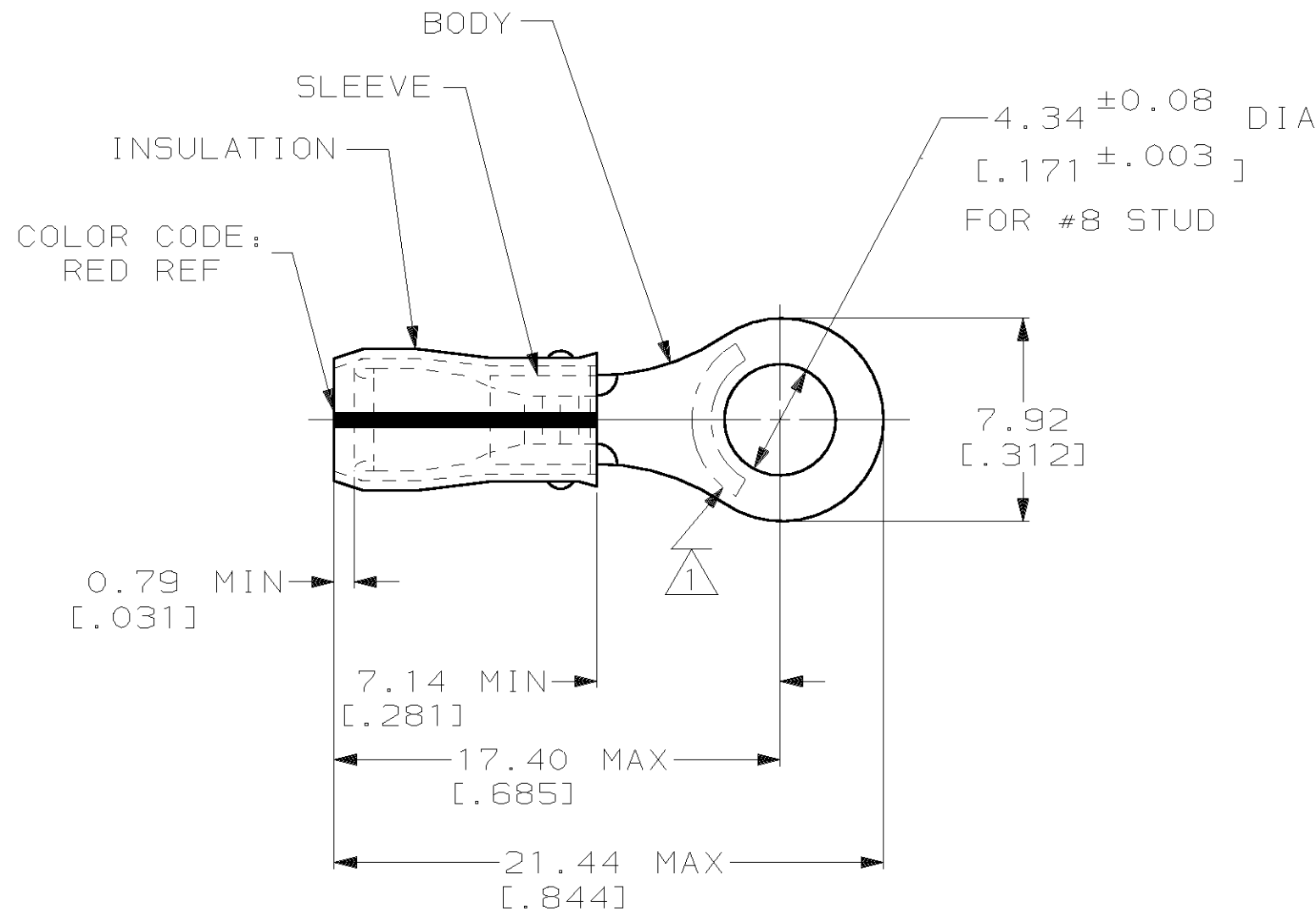

- ① STAMP AMP 22-18\* APPROX AS SHOWN  
22-16 TERMINALS ARE STAMPED 22-18 IN ACCORDANCE WITH MILITARY SPEC MIL-T-7928  
COMMERCIAL WIRE RANGE IS 22-16
- 2 WIRE INSULATION DIA: .080 - .125
- 3 TONGUE MATERIAL THK: 0.79<sup>±0.05</sup> [.031<sup>±.002</sup>]
- ④ PRELIMINARY - NOT FOR PRODUCTION & EXPENSIVE PART, HAND CRAFTED.

<b>AMP INCORPORATED CUSTOMER SERVICE SYSTEMS</b>		MAX RECOMMENDED OPERATING TEMPERATURE: 150°C MAX	1000	LOOSE PIECE	④ 696242-1																							
FOR ADDITIONAL PRODUCT INFORMATION OR COPIES OF DRAWINGS AND TECHNICAL DOCUMENTS	PRODUCT INFORMATION CENTER 1-800-522-6752	VOLTAGE RATING: NOT APPLICABLE	QUANTITY	PACKAGE TYPE	PART NO																							
FOR APPLICATION TOOLING INFORMATION	TOOLING ASSISTANCE CENTER 1-800-722-1111	CIRCULAR MIL AREA: 0.26-1.65mm <sup>2</sup> [509-3,260] STRANDED	<table border="1"> <tr> <td>DR 02JAN01 JR RUTH</td> <td rowspan="4"><b>AMP</b> AMP Incorporated Harrisburg, PA 17105-3608</td> </tr> <tr> <td>CHK 02JAN01 MS FEHER</td> </tr> <tr> <td>APPD 02JAN01 T MICHIELUTTI</td> </tr> <tr> <td>APPD 02JAN01 T MICHIELUTTI</td> </tr> <tr> <td>MATERIAL BODY &amp; SLEEVE: COPPER PER ASTM B152 INSULATION: PVF<sub>2</sub> NATURAL</td> <td>NAME TERMINAL, RING TONGUE, PVF<sub>2</sub>, P.I.D.G.<sup>TM</sup> WIRE SIZE: 22-16 AWG</td> </tr> <tr> <td>FINISH BODY &amp; SLEEVE: TIN/LEAD (60-40) PLATE PER SAE-AMS-P-81728</td> <td>PRODUCT SPEC 108-11023</td> <td>SIZE B</td> <td>CAGE CODE 00779</td> <td>DRAWING NO C-696242</td> </tr> <tr> <td></td> <td>APPLICATION SPEC NOT AVAILABLE</td> <td>SCALE 4:1</td> <td colspan="2">SHEET 1 OF 1</td> </tr> <tr> <td>FOR ORDER ENTRY</td> <td>1-800-526-5142</td> <td>THIS DRAWING IS A CONTROLLED DOCUMENT FOR AMP INCORPORATED. IT IS SUBJECT TO CHANGE AND THE CONTROLLING ENGINEERING ORGANIZATION SHOULD BE CONTACTED FOR THE LATEST REVISION.</td> <td>WEIGHT -</td> <td colspan="2"></td> </tr> </table>			DR 02JAN01 JR RUTH	<b>AMP</b> AMP Incorporated Harrisburg, PA 17105-3608	CHK 02JAN01 MS FEHER	APPD 02JAN01 T MICHIELUTTI	APPD 02JAN01 T MICHIELUTTI	MATERIAL BODY & SLEEVE: COPPER PER ASTM B152 INSULATION: PVF <sub>2</sub> NATURAL	NAME TERMINAL, RING TONGUE, PVF <sub>2</sub> , P.I.D.G. <sup>TM</sup> WIRE SIZE: 22-16 AWG	FINISH BODY & SLEEVE: TIN/LEAD (60-40) PLATE PER SAE-AMS-P-81728	PRODUCT SPEC 108-11023	SIZE B	CAGE CODE 00779	DRAWING NO C-696242		APPLICATION SPEC NOT AVAILABLE	SCALE 4:1	SHEET 1 OF 1		FOR ORDER ENTRY	1-800-526-5142	THIS DRAWING IS A CONTROLLED DOCUMENT FOR AMP INCORPORATED. IT IS SUBJECT TO CHANGE AND THE CONTROLLING ENGINEERING ORGANIZATION SHOULD BE CONTACTED FOR THE LATEST REVISION.	WEIGHT -		
DR 02JAN01 JR RUTH	<b>AMP</b> AMP Incorporated Harrisburg, PA 17105-3608																											
CHK 02JAN01 MS FEHER																												
APPD 02JAN01 T MICHIELUTTI																												
APPD 02JAN01 T MICHIELUTTI																												
MATERIAL BODY & SLEEVE: COPPER PER ASTM B152 INSULATION: PVF <sub>2</sub> NATURAL	NAME TERMINAL, RING TONGUE, PVF <sub>2</sub> , P.I.D.G. <sup>TM</sup> WIRE SIZE: 22-16 AWG																											
FINISH BODY & SLEEVE: TIN/LEAD (60-40) PLATE PER SAE-AMS-P-81728	PRODUCT SPEC 108-11023	SIZE B	CAGE CODE 00779	DRAWING NO C-696242																								
	APPLICATION SPEC NOT AVAILABLE	SCALE 4:1	SHEET 1 OF 1																									
FOR ORDER ENTRY	1-800-526-5142	THIS DRAWING IS A CONTROLLED DOCUMENT FOR AMP INCORPORATED. IT IS SUBJECT TO CHANGE AND THE CONTROLLING ENGINEERING ORGANIZATION SHOULD BE CONTACTED FOR THE LATEST REVISION.	WEIGHT -																									