

THIS DRAWING IS UNPUBLISHED. RELEASED FOR PUBLICATION
 © COPYRIGHT - By - ALL RIGHTS RESERVED.

| LOC | DIST | REVISIONS | | | | | |
|-----|------|-----------|-----|---------------------------|-----------|-----|------|
| CM | 00 | P | LTR | DESCRIPTION | DATE | DWN | APVD |
| | | J | | REVISED PER ECR-20-000824 | 29MAY2020 | PC | SW |

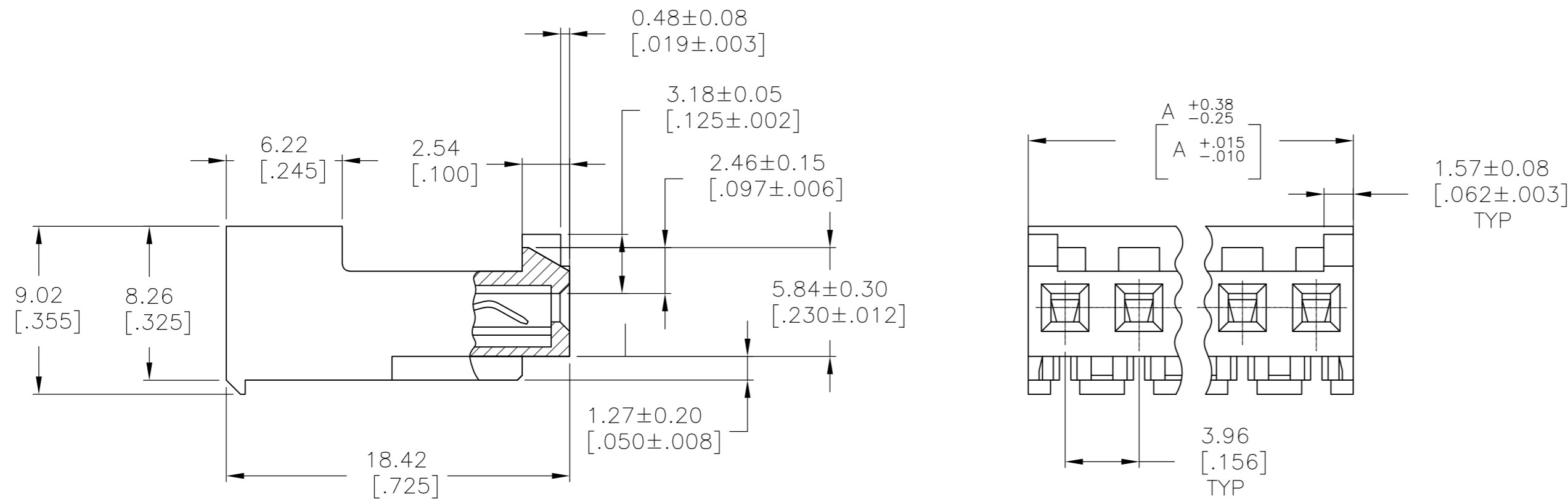
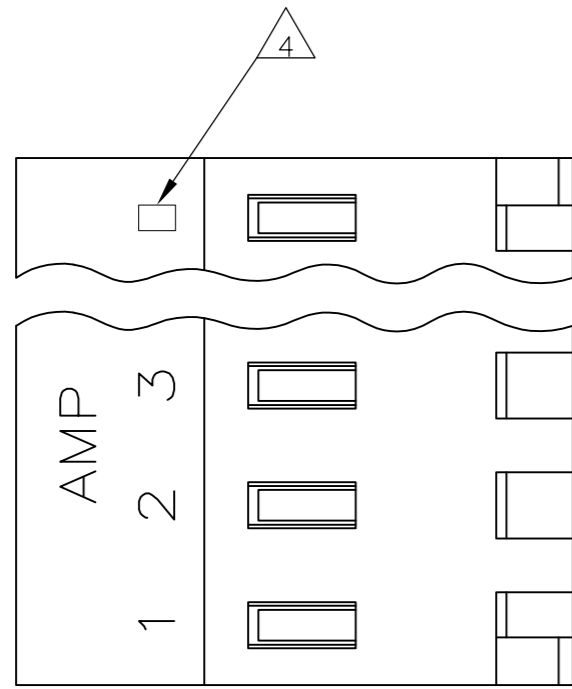

| | | |
|--------------|----|------------|
| 95.10[3.744] | 24 | 5-643820-4 |
| 91.13[3.588] | 23 | 5-643820-3 |
| 87.17[3.432] | 22 | 5-643820-2 |
| 83.21[3.276] | 21 | 5-643820-1 |
| 79.25[3.120] | 20 | 5-643820-0 |
| 75.29[2.964] | 19 | 4-643820-9 |
| 71.32[2.808] | 18 | 4-643820-8 |
| 67.36[2.652] | 17 | 4-643820-7 |
| 63.40[2.496] | 16 | 4-643820-6 |
| 59.44[2.340] | 15 | 4-643820-5 |
| 55.47[2.184] | 14 | 4-643820-4 |
| 51.51[2.028] | 13 | 4-643820-3 |
| 47.55[1.872] | 12 | 4-643820-2 |
| 43.59[1.716] | 11 | 4-643820-1 |
| 39.62[1.560] | 10 | 4-643820-0 |
| 35.66[1.404] | 9 | 3-643820-9 |
| 31.70[1.248] | 8 | 3-643820-8 |
| 27.74[1.092] | 7 | 3-643820-7 |
| 23.77[.936] | 6 | 3-643820-6 |
| 19.81[.780] | 5 | 3-643820-5 |
| 15.85[.624] | 4 | 3-643820-4 |
| 11.89[.468] | 3 | 3-643820-3 |
| 7.92[.312] | 2 | 3-643820-2 |

- 1 MATERIAL: CONNECTOR - NYLON UL94-V2 (WHITE)
CONTACTS - 0.30[.012] THICK COPPER ALLOY (BRIGHT TIN-LEAD 0.00203[.000080] MIN. THICK FOR CONTACTS 643820-2 THRU 2-643820-4). (MATTE WHISKER MITIGATED TIN 0.00203[.000080] MIN. THICKNESS OVER NICKEL UNDERPLATE FOR 3-643820-2 THRU 5-643820-4).
- 2. CONTACTS ACCEPT 24 AWG WIRE WITH 2.41[.095] MAX INSULATION DIAMETER.
- 3. CONTACTS MUST ACCEPT 1.14±0.03[.045±.001] POST AND REMAIN LOCKED IN POSITION.
- 4 IDENTIFICATION NUMBER FOR LAST CIRCUIT MAY NOT APPEAR ON ALL ASSEMBLIES.
- 5. DIMENSIONS IN BRACKETS ARE IN INCHES.
- 6. HOUSING FEATURES ARE: CLOSED END WITH LOCKING RAMP AND POLARIZING TAB.
- 7 OBSOLETE PARTS: OBSOLETE CIS STREAMLINING PER D.RENAUD/D.SINISI
- 8 OBSOLETE PARTS

| | | | | |
|---|--------------------------|--------------|----|------------|
| △ | SUPERSEDED BY 5-643820-4 | 95.10[3.744] | 24 | 2-643820-4 |
| △ | SUPERSEDED BY 5-643820-3 | 91.13[3.588] | 23 | 2-643820-3 |
| △ | SUPERSEDED BY 5-643820-2 | 87.17[3.432] | 22 | 2-643820-2 |
| △ | SUPERSEDED BY 5-643820-1 | 83.21[3.276] | 21 | 2-643820-1 |
| △ | SUPERSEDED BY 5-643820-0 | 79.25[3.120] | 20 | 2-643820-0 |
| △ | SUPERSEDED BY 4-643820-9 | 75.29[2.964] | 19 | 1-643820-9 |
| △ | SUPERSEDED BY 4-643820-8 | 71.32[2.808] | 18 | 1-643820-8 |
| △ | SUPERSEDED BY 4-643820-7 | 67.36[2.652] | 17 | 1-643820-7 |
| △ | SUPERSEDED BY 4-643820-6 | 63.40[2.496] | 16 | 1-643820-6 |
| △ | SUPERSEDED BY 4-643820-5 | 59.44[2.340] | 15 | 1-643820-5 |
| △ | SUPERSEDED BY 4-643820-4 | 55.47[2.184] | 14 | 1-643820-4 |
| △ | SUPERSEDED BY 4-643820-3 | 51.51[2.028] | 13 | 1-643820-3 |
| △ | SUPERSEDED BY 4-643820-2 | 47.55[1.872] | 12 | 1-643820-2 |
| △ | SUPERSEDED BY 4-643820-1 | 43.59[1.716] | 11 | 1-643820-1 |
| | OBSOLETE | 39.62[1.560] | 10 | 1-643820-0 |
| △ | SUPERSEDED BY 3-643820-9 | 35.66[1.404] | 9 | -643820-9 |
| △ | SUPERSEDED BY 3-643820-8 | 31.70[1.248] | 8 | -643820-8 |
| △ | SUPERSEDED BY 3-643820-7 | 27.74[1.092] | 7 | -643820-7 |
| △ | SUPERSEDED BY 3-643820-6 | 23.77[.936] | 6 | -643820-6 |
| △ | SUPERSEDED BY 3-643820-5 | 19.81[.780] | 5 | -643820-5 |
| △ | SUPERSEDED BY 3-643820-4 | 15.85[.624] | 4 | -643820-4 |
| △ | SUPERSEDED BY 3-643820-3 | 11.89[.468] | 3 | -643820-3 |
| △ | SUPERSEDED BY 3-643820-2 | 7.92[.312] | 2 | -643820-2 |

| | | | | |
|--|--------|----------------------------------|--|----------|
| THIS DRAWING IS A CONTROLLED DOCUMENT. | | DWN S. CARPENTER 09JUL2003 | | |
| DIMENSIONS: mm [INCHES] | | CHK D. BOSSI 09JUL2003 | | |
| TOLERANCES UNLESS OTHERWISE SPECIFIED: | | APVD D. BOSSI 09JUL2003 | NAME | |
| 0 PLC ± - | | PRODUCT SPEC | MTA 156 CONNECTOR ASSEMBLY, 24 AWG, STANDARD | |
| 1 PLC ± - | | 108-1051 | SIZE | A2 |
| 2 PLC ± - | | APPLICATION SPEC | CAGE CODE | 00779 |
| 3 PLC ± 0.13 [.005] | | 114-1020 | DRAWING NO | C=643820 |
| 4 PLC ± - | FINISH | WEIGHT | RESTRICTED TO | - |
| ANGLES ± - | | CUSTOMER DRAWING | SCALE | 4:1 |
| | | | SHEET | 1 of 1 |
| | | | REV | J |