

THIS DRAWING IS UNPUBLISHED. RELEASED FOR PUBLICATION
 © COPYRIGHT - By - ALL RIGHTS RESERVED.

REVISIONS				
P	LTR	DESCRIPTION	DATE	APVD
G4		REVISED PER ECR-16-014021	06OCT2016	BW RS

1. CONTINUOUS STRIP ON REEL.
 △ WIRE SIZE IS [22-18] AWG.

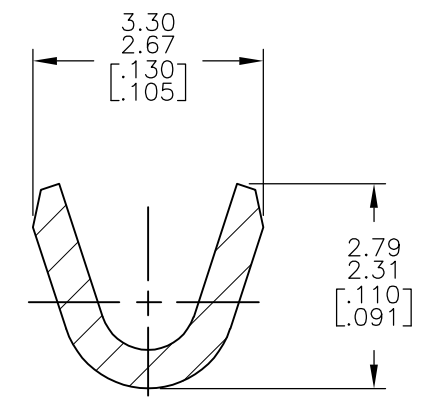
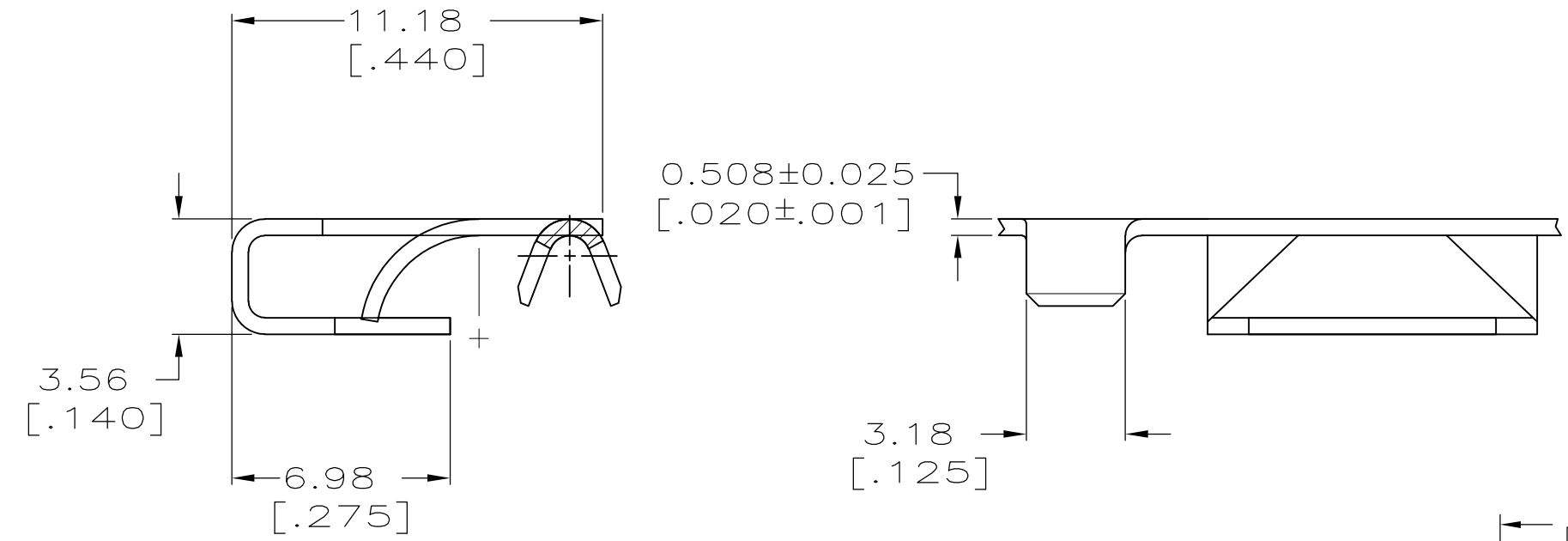

SECTION A-A
 SCALE 10:1
 -1 THRU -3

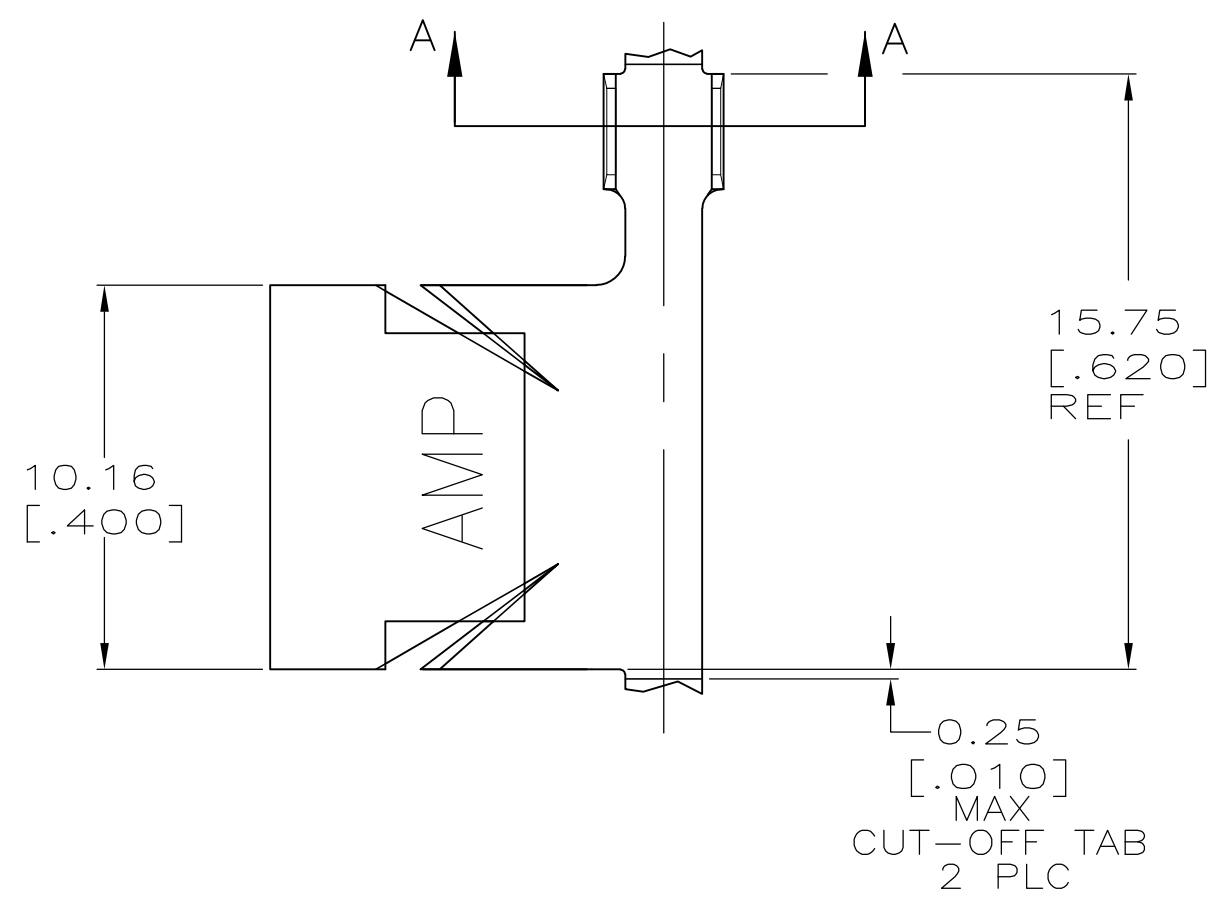

	MATERIAL	PART NO.
OBSOLETE	UNS G10080 TEMP 2 STEEL	63733-4
△	UNS C52100 H04 PHOS BRZ	63733-3
OBSOLETE	UNS C26000 H06 BRASS	63733-2
△	UNS G10080 TEMP 2 STEEL	63733-1

THIS DRAWING IS A CONTROLLED DOCUMENT.		DWN PHIL FORTNEY 8/3/93	STE TE Connectivity	
DIMENSIONS: MM [INCHES]		CHK JR RUTH 8/3/93		
TOLERANCES UNLESS OTHERWISE SPECIFIED:		APVD R KUZO 8/3/93	NAME CLIP, GROUNDING	
0 PLC ± -		PRODUCT SPEC	SIZE CAGE CODE DRAWING NO RESTRICTED TO	
1 PLC ± -		APPLICATION SPEC	A3 00779 C-63733	
2 PLC ± 0.25 [.010]		WEIGHT -	SCALE 5:1 SHEET 1 OF 1 REV G4	
3 PLC ± -		CUSTOMER DRAWING		
4 PLC ± -				
ANGLES ± -				
MATERIAL SEE TABLE		FINISH 0.002032 [.000080]MIN TIN		