

THIS DRAWING IS UNPUBLISHED. RELEASED FOR PUBLICATION  
 © COPYRIGHT - By - ALL RIGHTS RESERVED.

LOC	DIST	REVISIONS					
AF	50	P	LTR	DESCRIPTION	DATE	DWN	APVD
			D2	REVISED PER ECR-20-009164	5AUG2020	MK	DH

1 CONTINUOUS STRIP ON REELS

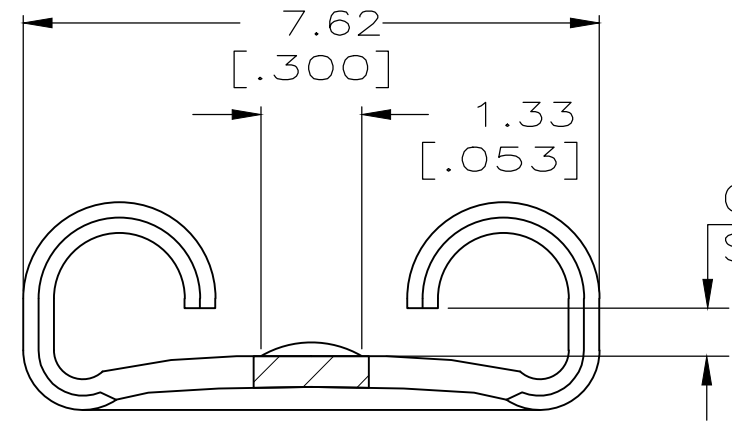
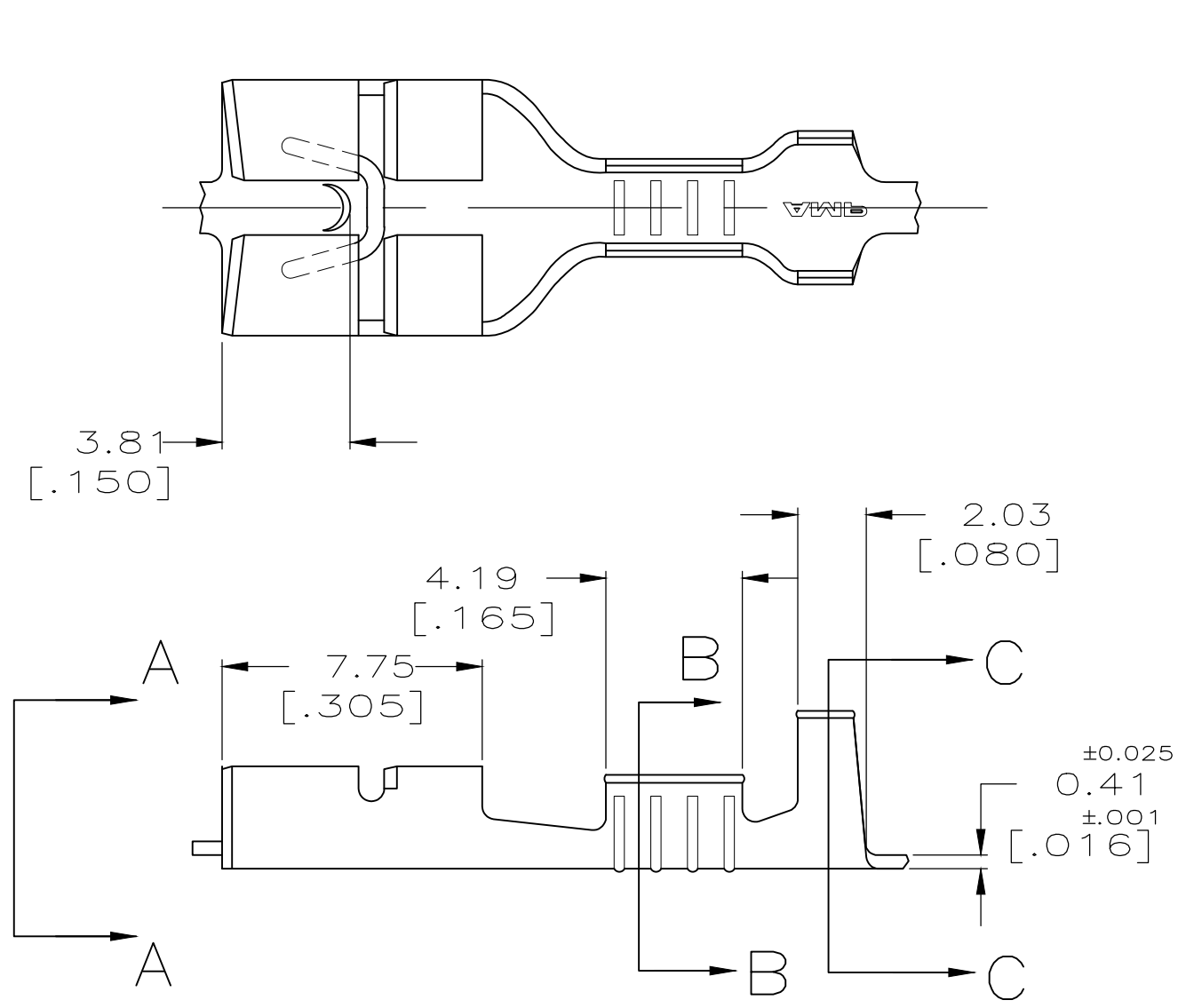

GAP AS REQUIRED TO MEET FORCE SPECIFICATIONS AND 0.71 [.028] MAX

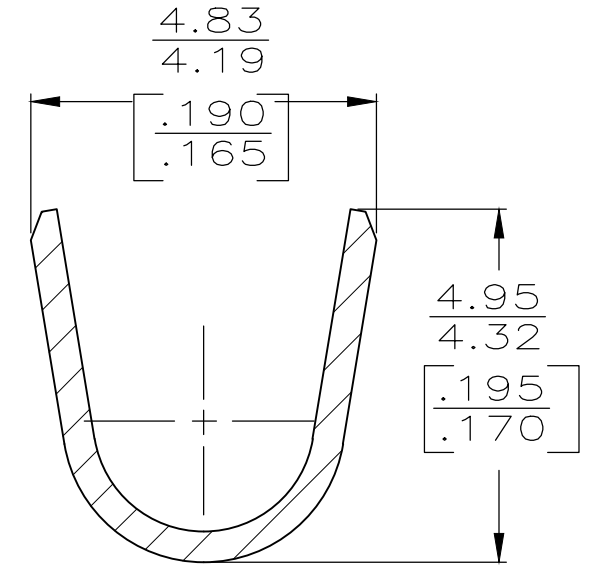
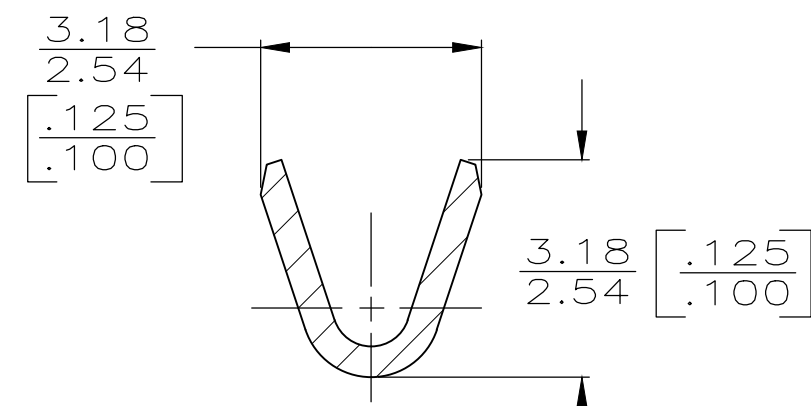

2.29-3.30 [.090-.130] DIA	0.3-0.8mm <sup>2</sup> [22-18] AWG	0.84-0.76 [.033-.030]	TIN	63609-2
INSULATION RANGE	WIRE SIZE	MATING TAB THK	-	63609-1
			FINISH	PART NO

F, 0, OR OVERLAP	3.30 [.130]	5.59 [.220]	F	2.29 [.090]	1.42 [.056]	0.8mm <sup>2</sup> [18]
TYPE	WIDTH	STRIP LENGTH ±0.38 ±[.015]	TYPE	WIDTH	HEIGHT ±.051 [±.002]	WIRE
INSUL BARREL CRIMP			WIRE BARREL CRIMP			

THIS DRAWING IS A CONTROLLED DOCUMENT.

DIMENSIONS: mm [INCHES]

TOLERANCES UNLESS OTHERWISE SPECIFIED:

0 PLC	± -
1 PLC	± -
2 PLC	± 0.25 [.010]
3 PLC	± -
4 PLC	± -
ANGLES	± -
FINISH	SEE TABLE

MATERIAL: BRASS

DWN	JR RUTH	4/3/91
CHK	P FORTNEY	4/3/91
APVD	C MEYERS	4/3/91
PRODUCT SPEC	-	-
APPLICATION SPEC	-	-
WEIGHT	-	-
CUSTOMER DRAWING		

**STE** TE Connectivity

RECEPTACLE, FASTON, 6.35 [.250] SERIES

SIZE	CAGE CODE	DRAWING NO	RESTRICTED TO
A3	00779	C-63609	-

SCALE 5:1 SHEET 1 OF 1 REV D2