

THIS DRAWING IS UNPUBLISHED. RELEASED FOR PUBLICATION  
 © COPYRIGHT - By - ALL RIGHTS RESERVED.

REVISIONS					
P	LTR	DESCRIPTION	DATE	DWN	APVD
	V	REVISED PER ECO-16-012447	26SEPT16	RS	DH

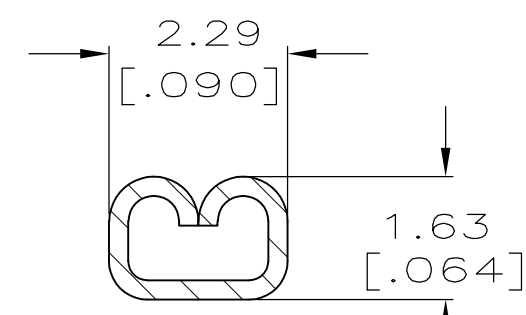

SECTION A-A  
SCALE 10:1

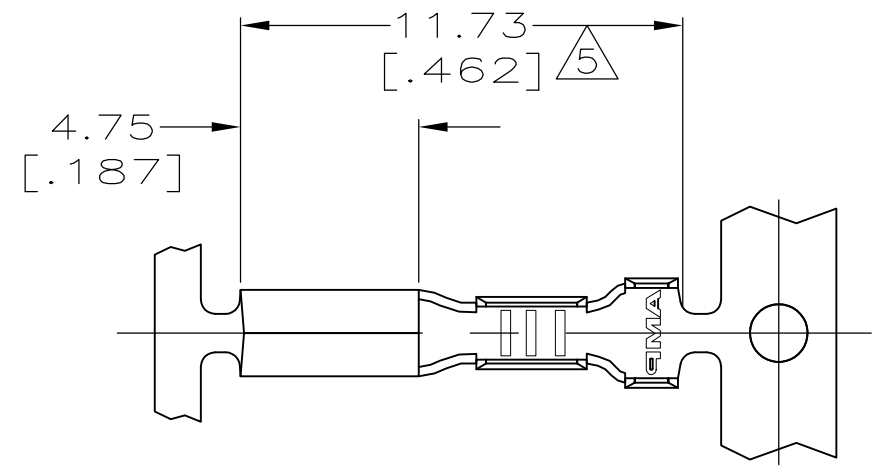
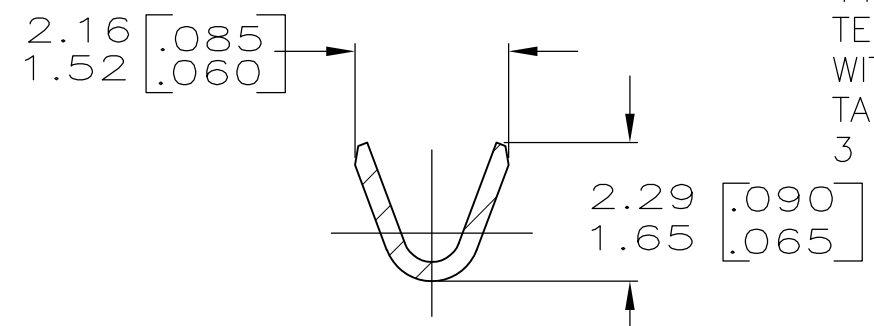
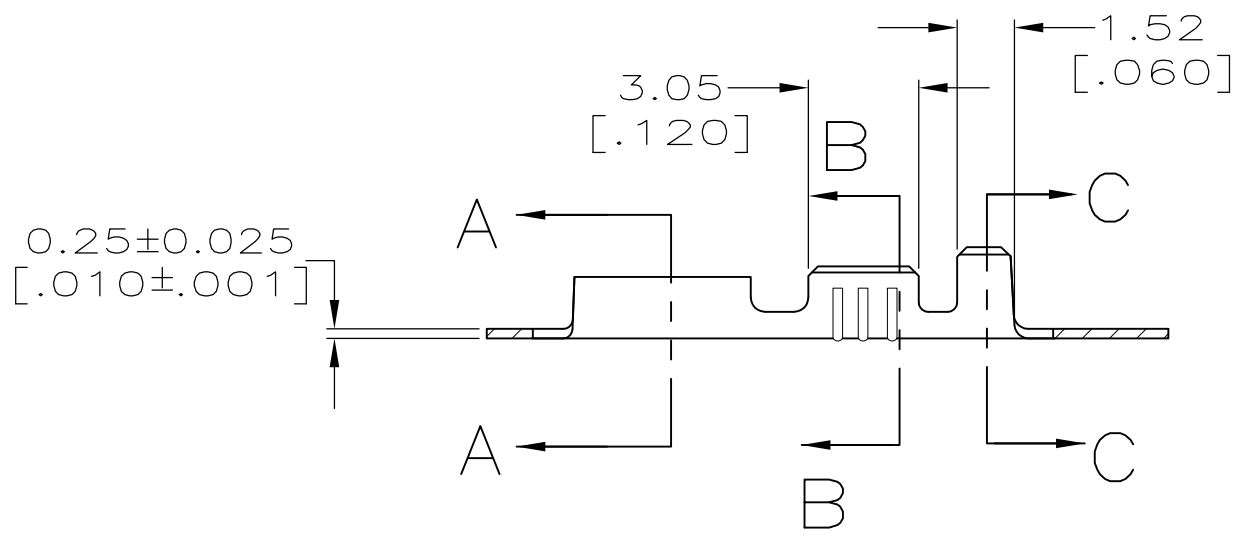

SECTION B-B  
SCALE 10:1

- 1 CONTINUOUS STRIP ON REELS.
- 2 FEED IS 8.89±0.13 [.350±.005]
- △3 TIN PLATE 0.002032 [.000080] MIN.
- △4 GOLD PLATE 0.000381 [.000015] MIN OVER 0.000762 [.000030] MIN THK NICKEL.
- △5 GOLD PLATE REQUIRED IN THIS AREA ONLY.
- △6 REVERSE REELING.
- 7 MAX TEST TAB MUST ENTER & WITHDRAW FROM RECPT. WITH A MAX FORCE OF 11 LBS. (USE GAGE 100716-40). MIN TEST TAB MUST WITHDRAW FROM RECPT WITH MIN PULL OF 1 LB AFTER MAX TAB HAS BEEN INSERTED & WITHDRAWN 3 TIMES.

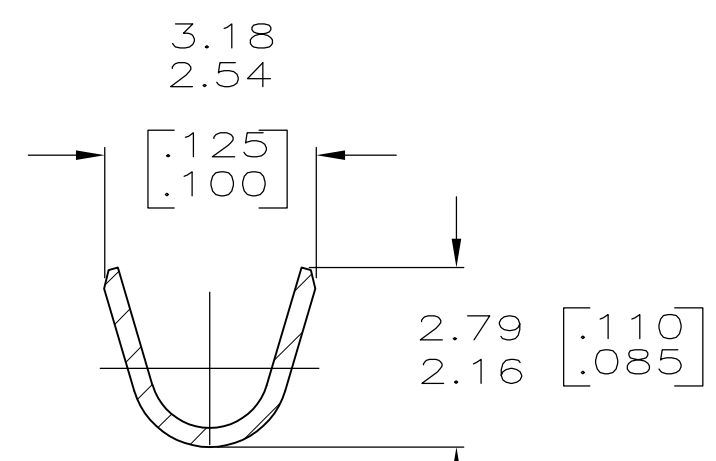

SECTION C-C  
SCALE 10:1

FINISH	INSULATION RANGE	WIRE SIZE	MATING TAB THK	PART NO.
△6 OBSOLETE — GOLD △4 △6 △3 TIN	1.02-2.03 DIA [.040-.080] DIA	[#24-#22] AWG	±0.025 0.79 X 1.58 ±.001 [.031 X .062]	60900-5- 60900-4 60900-3
OBSOLETE — GOLD △4 OBSOLETE △3 TIN				60900-2- 60900-1-

THIS DRAWING IS A CONTROLLED DOCUMENT.		DWN JR RUTH 1/24/95	<b>STE</b> TE Connectivity		
DIMENSIONS: mm [INCHES]		CHK MS FEHER 1/24/95			
TOLERANCES UNLESS OTHERWISE SPECIFIED:		APVD R REINER 1/24/95	NAME		
0 PLC ± -	1 PLC ± -	PRODUCT SPEC	RECEPTACLE, TAB, WRAP TYPE		
2 PLC ± 0.25 [.010]	3 PLC ± -	APPLICATION SPEC	SIZE	CAGE CODE	DRAWING NO
4 PLC ± -	ANGLES ± -	MATERIAL	0	A300779	C-60900
FINISH SEE TABLE		RESTRICTED TO	—		
BRASS		CUSTOMER DRAWING	SCALE 5:1	SHEET 1 OF 1	REV V