

THIS DRAWING IS UNPUBLISHED. RELEASED FOR PUBLICATION  
 © COPYRIGHT - BY TYCO ELECTRONICS CORPORATION. ALL RIGHTS RESERVED.

LOC	DIST	REVISIONS					
GA	1	P	LTR	DESCRIPTION	DATE	DWN	APVD
			C	PER LC20-0248-07 / ECO-07-023130	24OCT07	DM	BJ

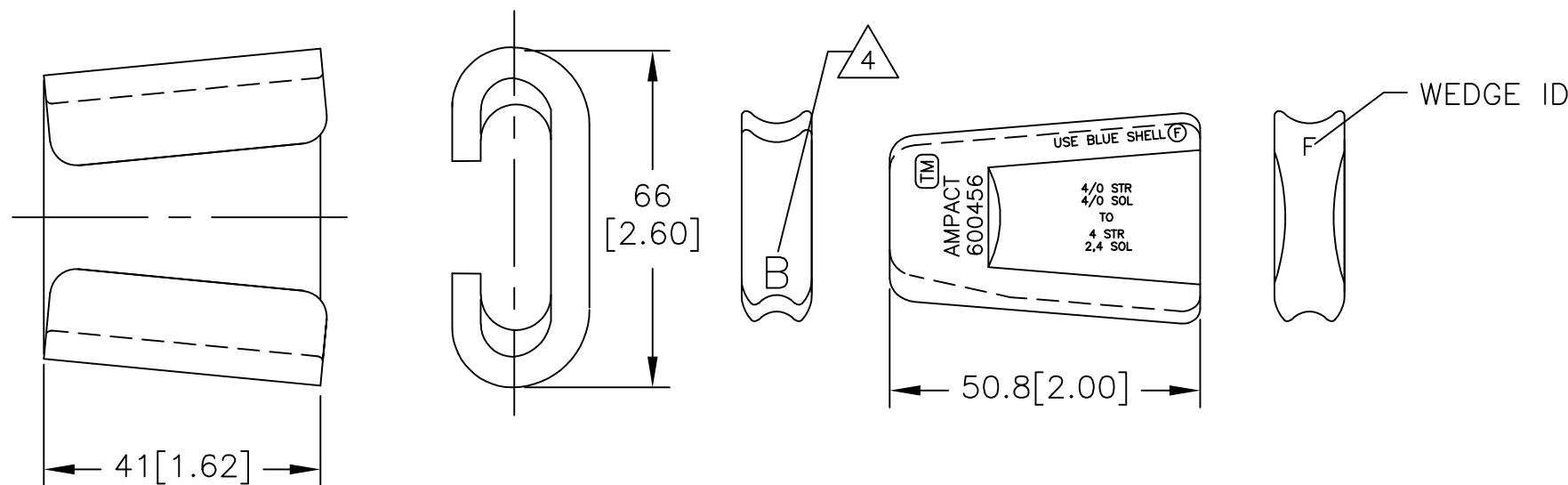

- DIMENSIONS ARE FOR REFERENCE ONLY.
  - INHIBITOR IS APPLIED AT FACTORY TO GROOVES OF 'C' BODY AND WEDGE.
  - FOR CONNECTOR P/N 600456, WIRE SIZES ARE MARKED ON WEDGE. USE BLUE CARTRIDGE P/N 69338-1 AND INSTALL 600456 WITH AMP TOOL P/N 69437.
- △ 4 FOR CONNECTOR P/N 600456-1, WEDGE IS MARKED WITH LETTER "B" ON FRONT FACE. NO WIRE SIZE, WEDGE ID & P/N ARE SHOWN ON THE WEDGE. 600456-1 IS INSTALLED WITH BATTERY TOOL ONLY.

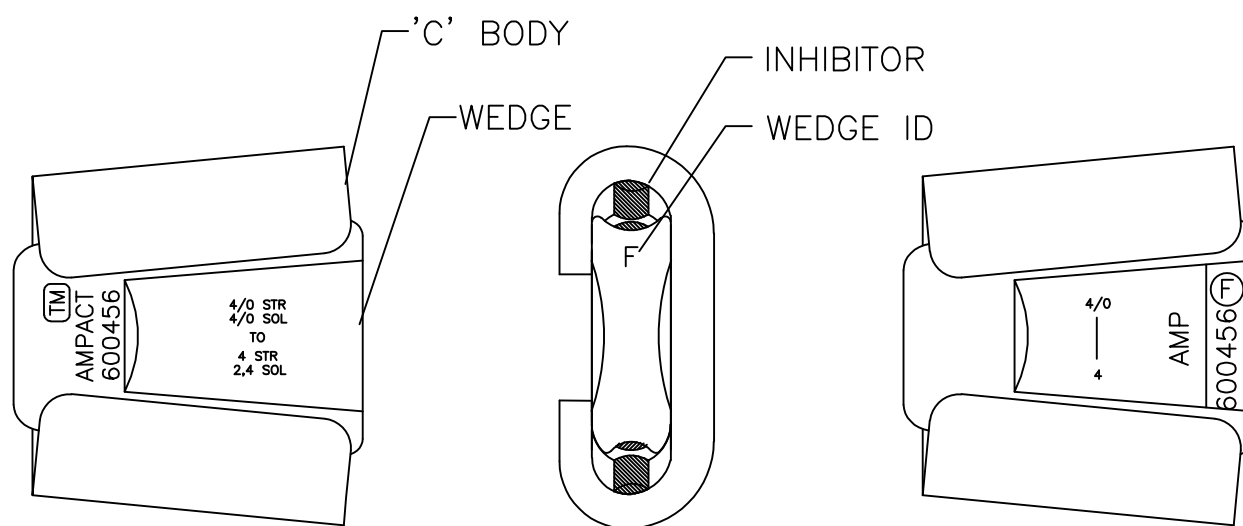

ALTERNATE MARKING ON WEDGE

ALUM. ALLOY	ALUM. ALLOY	600456-1
ALUM. ALLOY	ALUM. ALLOY	600456
WEDGE QTY: 1	'C' BODY QTY: 1	PART NO.

THIS DRAWING IS A CONTROLLED DOCUMENT.		DWN	M. SAYMAN	26 JUN 97	Tyco Electronics Corporation Markham, ON L3R-1E1				
DIMENSIONS: MM [INCHES]		CHK	G. MENCHELLA	30 JUN 97					
TOLERANCES UNLESS OTHERWISE SPECIFIED:		APVD	P. CHAN	30 JUN 97	NAME				
0 PLC ± 1 PLC ± 2 PLC ± 3 PLC ± 4 PLC ± ANGLES ±		PRODUCT SPEC		CONNECTOR, 4/0-4, MEDIUM SERIES, BLUE CODED, AMPACT					
MATERIAL SEE TABLE		FINISH		-		SIZE	CAGE CODE	DRAWING NO	RESTRICTED TO
				-		A3	00779	C-600456	-
CUSTOMER DRAWING					SCALE	NTS	SHEET	1 OF 1	REV
					C				