

THIS DRAWING IS UNPUBLISHED. RELEASED FOR PUBLICATION 2008
 © COPYRIGHT 2008 BY TYCO ELECTRONICS CORPORATION. ALL RIGHTS RESERVED.

LOC	DIST	REVISIONS			
P	LTR	DESCRIPTION	DATE	DWN	APVD
AI	-				

ERGOCRIMP HAND TOOL FOR MCON 2.8LL TERMINALS SWS - 0,75-1,0 mm²

Ergocrimp Matrize als Ersatzteil erhaeltlich
 TE P/N 8-1579022-4
 Ergocrimp die set as spare part available
 TE P/N 8-1579022-4

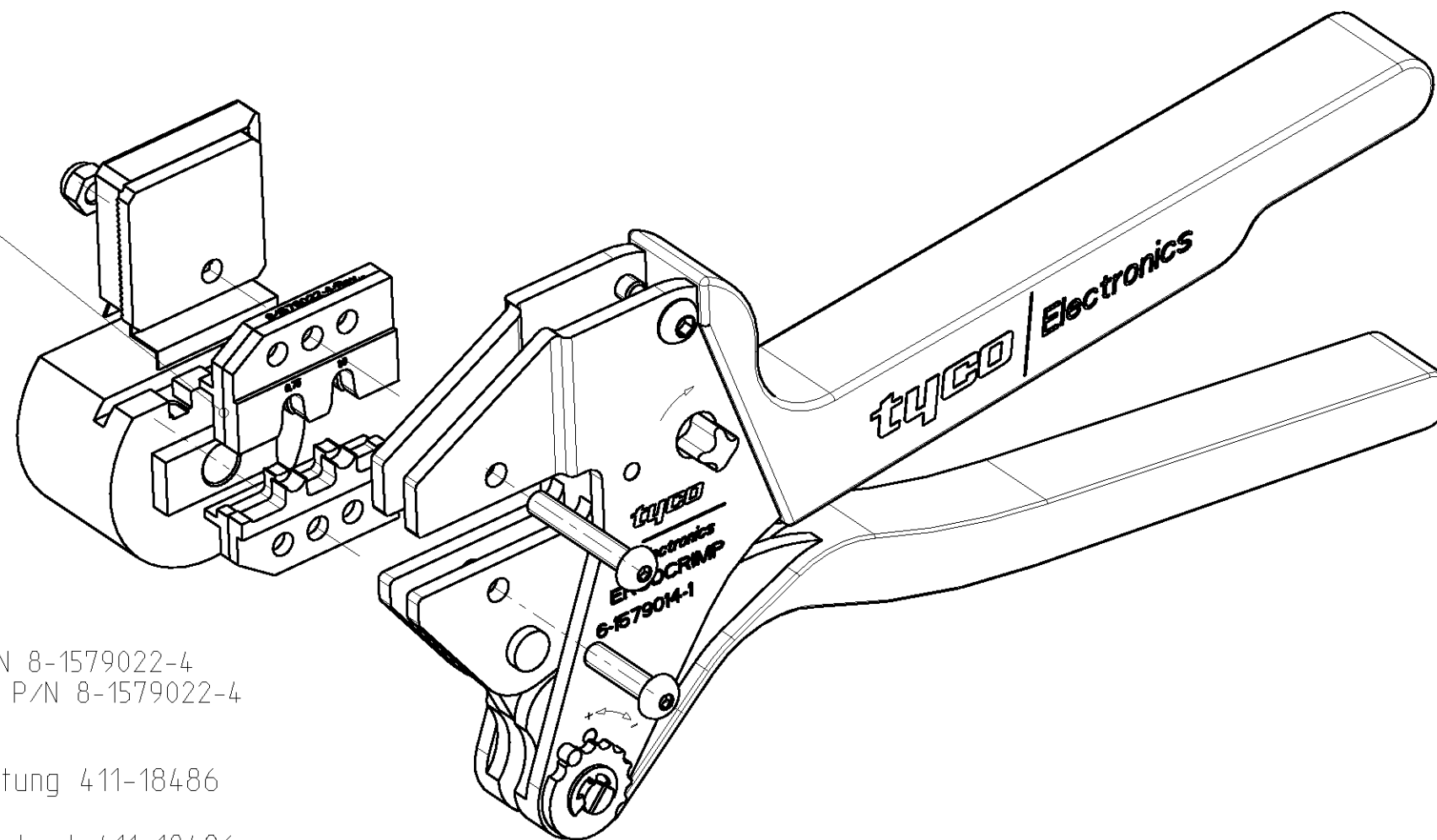

Einzelzeile der Ergocrimp Matrize bestellbar. Siehe Zeichnung TE P/N 8-1579022-4
 Spare parts of the Ergocrimp die set are available. See drawing TE P/N 8-1579022-4

Handzange mit Matrize zusammengebaut und mit Bedienungsanleitung 411-18486
 im Karton verpackt
 Hand tool assembled with die set and packed with instruction sheet 411-18486
 in a cardboard

Kontakt	DGB (mm ²)	Drahtcrimp / Wire Crimp		Isolationscrimp/Insulationcrimp		Isol.Ø	Betriebsanl.
Contact	Wire Range	Hoehe/Height mm	Breite/Width mm	Hoehe/Height mm	Breite/Width mm	Ins.Range	Instr.Sheet
1670803	0.75	1.18 ±0,05	2,03 F	4.20	4,06 0	1,4-2,1	411-18486
	1,00	1,27 ±0,05		4,50			

<small>THIS DRAWING IS A CONTROLLED DOCUMENT FOR TYCO ELECTRONICS CORPORATION IT IS SUBJECT TO CHANGE AND THE CONTROLLING ENGINEERING ORGANIZATION SHOULD BE CONTACTED FOR THE LATEST REVISION.</small>		DWN Ch.Witt	29SEP2008	Tyco Electronics AMP GmbH 64625 Bensheim (Germany)	
DIMENSIONS: mm 		TOLERANCES UNLESS OTHERWISE SPECIFIED: 0 PLC ± 1 PLC ± 2 PLC ± 3 PLC ± 4 PLC ± ANGLES ±1°		NAME ERGOCRIMP HAND TOOL FOR MCON 2.8LL TERMINALS SWS 0,75-1,0 mm ²	
MATERIAL -		FINISH -		PRODUCT SPEC - APPLICATION SPEC - WEIGHT 750 g	SIZE A3 CAGE CODE 00779 DRAWING NO C-6-1579014-1 RESTRICTED TO -
CUSTOMER DRAWING				SCALE 1:1	SHEET 1 OF 1 REV A