

| REVISIONS |           |                              |    |       |
|-----------|-----------|------------------------------|----|-------|
| REV       | DATE      | DESCRIPTION                  | BY | APP'D |
| D         | 27JUL2023 | REVISED AS PER ECN-23-226763 | JK | WH    |

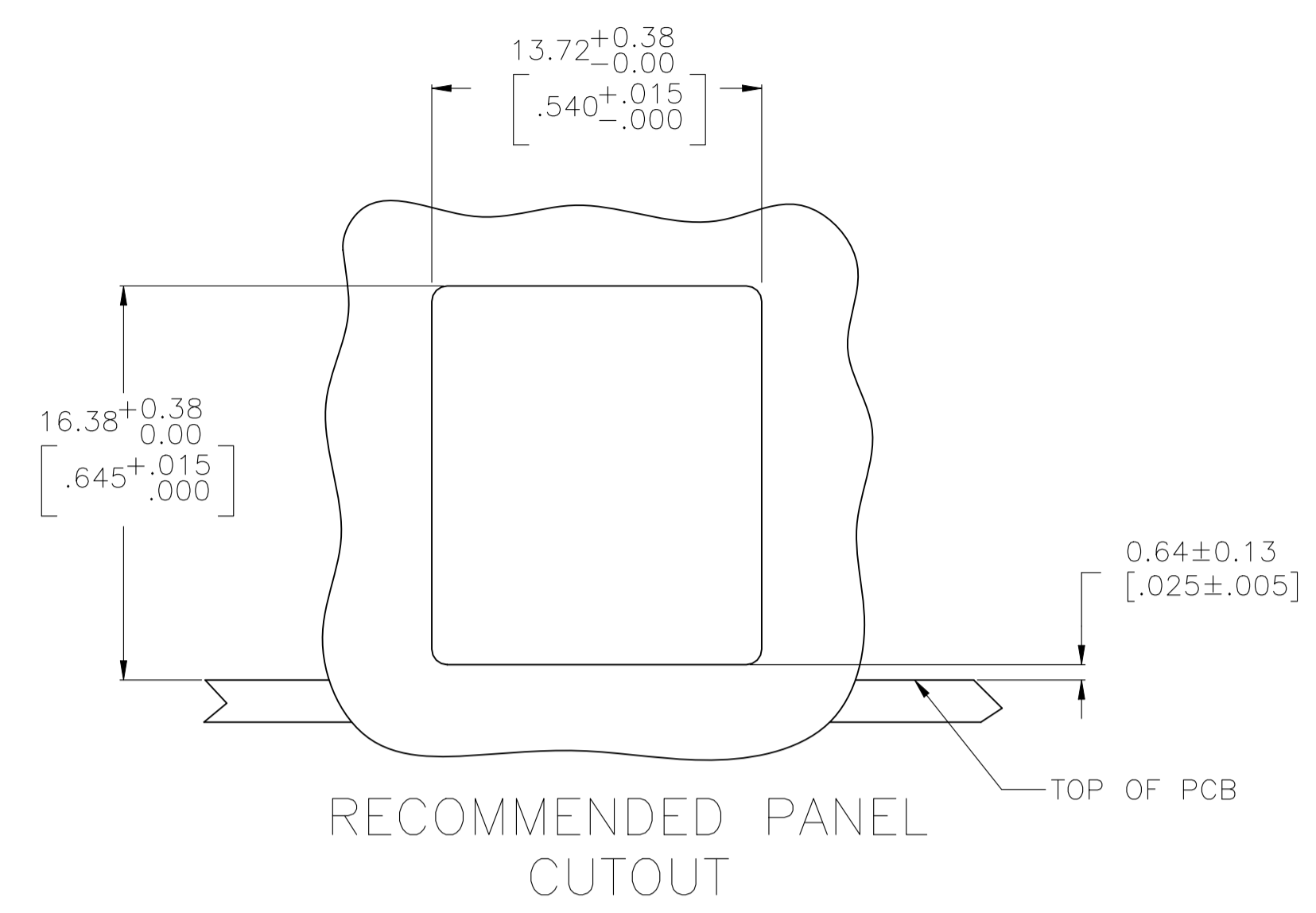

- MATERIAL: HOUSING – PBT POLYESTER, COLOR: BLACK  
 TERMINAL -- 0.35 [.0138] THICK PHOS BRONZE  
 PLATED IWTH 1.27 μm [.000050] THICK HARD GOLD  
 IN LOCALIZED GOLD PLATE AREA AND 3.81 μm [.000150]  
 THICK MATTE TIN IN SOLDER AREA OVER 1.27 μm  
 [.000050] THICK NICKEL UNDERPLATE
- CAVITY CONFORMS TO FCC RULES AND  
 REGULATIONS PART 68 AND REA BULLETIN  
 345-81, PE-76 SPECIFICATION FOR MODULAR  
 TELEPHONE HARDWARE.
- DIMENSIONS ARE MAXIMUM UNLESS OTHERWISE SHOWN

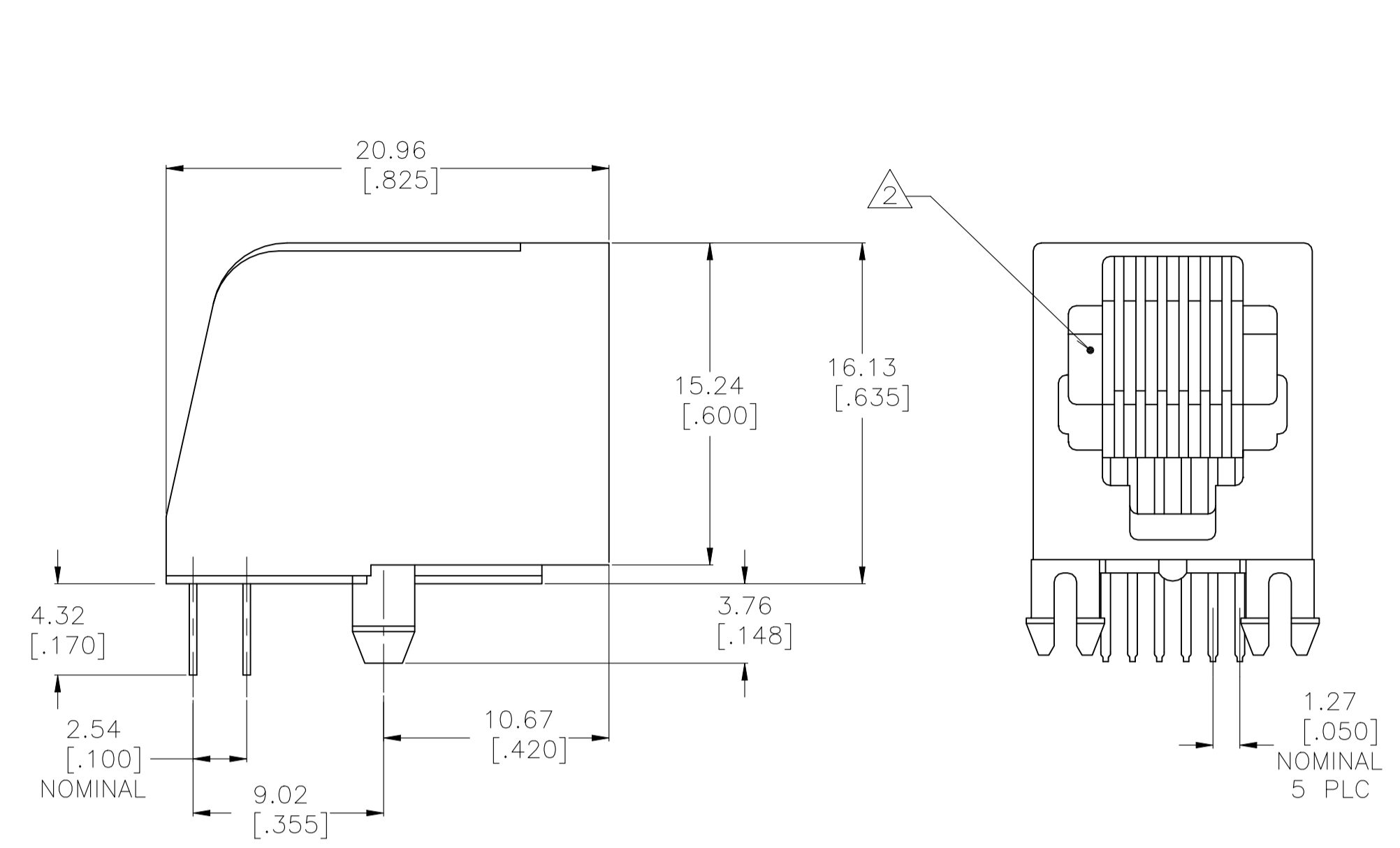
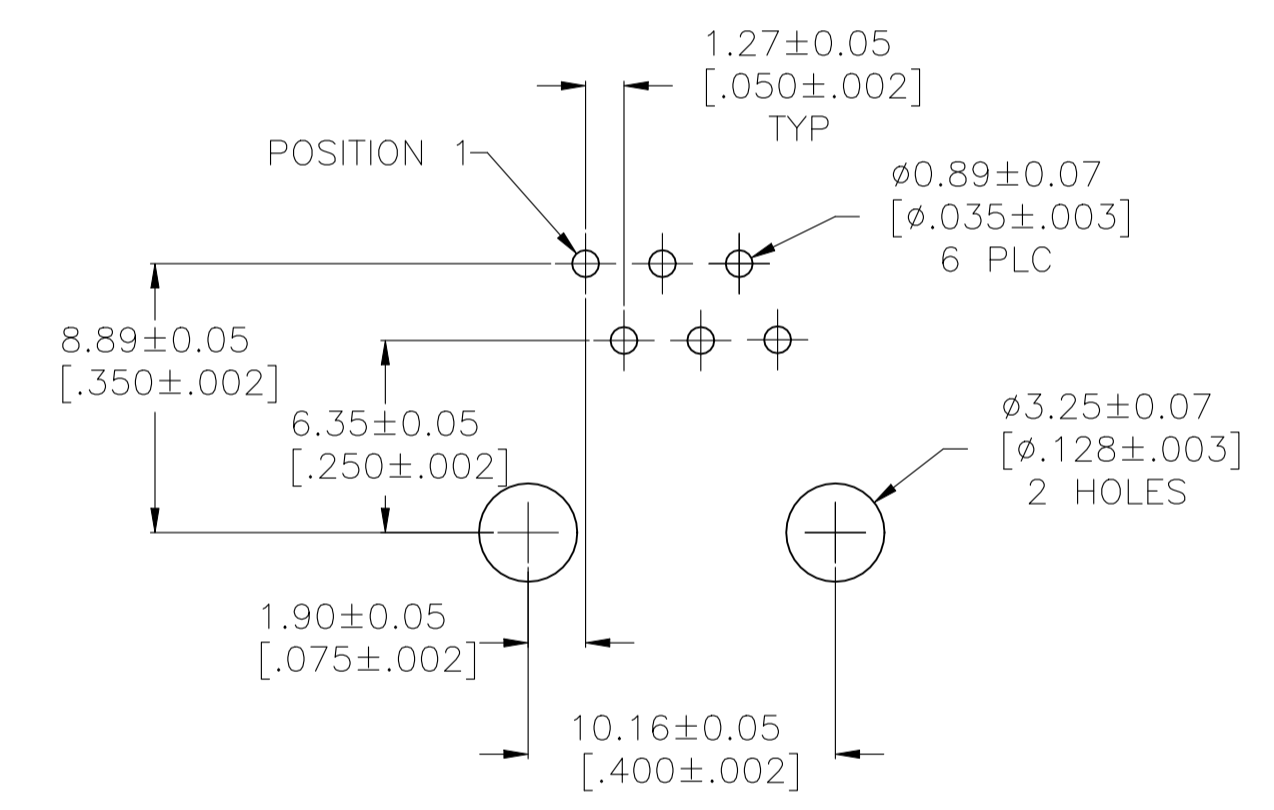
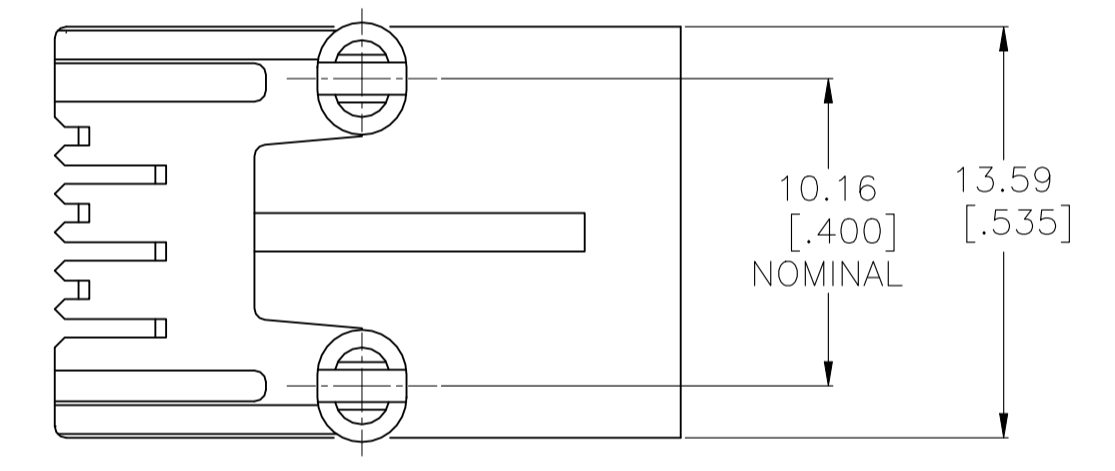

RECOMMENDED PRINTED CIRCUIT BOARD  
 LAYOUT  
 COMPONENT SIDE SHOWN

|         |           |             |
|---------|-----------|-------------|
| TUBE    | 6         | 5520470-4   |
| TRAY    | 6         | 5520470-3   |
| PACKAGE | TERMINALS | PART NUMBER |

|  |  |                  |           |                  |          |
|--|--|------------------|-----------|------------------|----------|
| THIS DRAWING IS A CONTROLLED DOCUMENT. |  | DIN              | 30AUG2007 | L.A.MAYER        |          |
|  |  | CHK              | 30AUG2007 | P.RECCCE         |          |
|  |  | APP'D            | 30AUG2007 | S.FLICKINGER     |          |
|  |  | PRODUCT SPEC     | 108-1163  |                  |          |
|  |  | APPLICATION SPEC | 114-2048  |                  |          |
| MATERIAL                               |  | SEE NOTE 1       | FINISH    | SEE NOTE 1       | WEIGHT   |
|  |  |                  |           |                  | 0.000000 |
|  |  |                  |           | SIZE             | A1       |
|  |  |                  |           | CAGE CODE        | 00779    |
|  |  |                  |           | DRAWING NO       | 5520470  |
|  |  |                  |           | RESTRICTED TO    | -        |
|  |  |                  |           | CUSTOMER DRAWING |          |
|  |  |                  |           | SCALE            | 4:1      |
|  |  |                  |           | SHEET            | 1 of 1   |
|  |  |                  |           | REV              | D        |