



Sealed EFI ECU 0.64/2.3 II I/O Connector

1. Part Names and Part Numbers

1.1 Housings

	Part Number*	Part Name
MALE CONNECTOR	1612272	Sealed 0.64/2.3 II I/O Conn.186Pos. Cap Housing Assembly STD Type
	1747536	Sealed 0.64/2.3 II I/O Conn.186Pos. Cap Housing Assembly Flange Type
	1827028	Sealed 0.64/2.3 II I/O Conn.186Pos. Cap Housing Assembly THS type
	1717313	Sealed 0.64/2.3 II I/O Conn.149Pos. Cap Housing Assembly STD Type
FEMALE CONNECTOR	1612275-3	Sealed 0.64/2.3 II I/O Conn.126Pos. Plug Housing Assembly STD Type(Clip conformable)
	1747137-3	Sealed 0.64/2.3 II I/O Conn.126Pos. Plug Housing Assembly Reverse Type(Clip conformable)
	1827021	Sealed 0.64/2.3 II I/O Conn.112Pos. Plug Housing Assembly THS STD Type
	1827022	Sealed 0.64/2.3 II I/O Conn.112Pos. Plug Housing Assembly THS Reverse Type
	1612275-4	Sealed 0.64/2.3 II I/O Conn. 89Pos. Plug Housing Assembly STD Type(Clip conformable)
	1747137-4	Sealed 0.64/2.3 II I/O Conn. 89Pos. Plug Housing Assembly Reverse Type(Clip conformable)
	1827014	Sealed 0.64/2.3 II I/O Conn. 74Pos. Plug Housing Assembly THS STD Type
	1827015	Sealed 0.64/2.3 II I/O Conn. 74Pos. Plug Housing Assembly THS Reverse Type
	1612283	Sealed 0.64/2.3 II I/O Conn. 60Pos. Plug Housing Assembly STD Type
	1747140	Sealed 0.64/2.3 II I/O Conn. 60Pos. Plug Housing Assembly Reverse Type
LEVER	1612281	Sealed 0.64/2.3 II I/O Conn. 126Pos. Lever STD Type
	1747139	Sealed 0.64/2.3 II I/O Conn. 126Pos. Lever Reverse Type
	1612288	Sealed 0.64/2.3 II I/O Conn. 60Pos. Lever STD Type
	1747142	Sealed 0.64/2.3 II I/O Conn. 60Pos. Lever Reverse Type
WIRE COVER	1746941	Sealed 0.64/2.3 II I/O Conn. 126Pos. Wire Cover Type I (Right and Left Lock)
	1746816	Sealed 0.64/2.3 II I/O Conn. 126Pos. Wire Cover Type II (One Side Lock)
	1871551	Sealed 0.64/2.3 II I/O Conn. 126Pos. Wire Cover Type III (Right and Left Lock)
	1903751	Sealed 0.64/2.3 II I/O Conn. 89Pos. Wire Cover Type V (Right and Left Lock)
	1981831	Sealed 0.64/2.3 II I/O Conn. 126Pos. Wire Cover Type VI (One Side Lock)
	1981984	Sealed 0.64/2.3 II I/O Conn. 126Pos. Wire Cover Type VII (Right and Left Lock)
	2069839	Sealed 0.64/2.3 II I/O Conn. 112Pos. Wire Cover Type I (Right and Left Lock)
	1871550	Sealed 0.64/2.3 II I/O Conn. 74Pos. Wire Cover Type I (Right and Left Lock)
	2040169	Sealed 0.64/2.3 II I/O Conn. 74Pos. Wire Cover Type II (One Side Lock)
	1746817	Sealed 0.64/2.3 II I/O Conn. 60Pos. Wire Cover Type I (One Side Lock)
	1827114	Sealed 0.64/2.3 II I/O Conn. 60Pos. Wire Cover Type II (Right and Left Lock)

Fig1(To be continued)

	Part Number*	Part Name
CLIP	1939393	Sealed 0.64/2.3 II I/O Conn. 89/126Pos. Clip

Fig.1(End)

*Note: Part number is consisted from listed base number and 1 digit numeric prefix and suffix with dash. Refer to catalog or customer drawing for specific part numbers for each base number. When prefix zero, zero and dash are omitted.

1.2 Terminals

<0.64 Terminals>

Part Number	Part Name	Wire Type	
		Type	Size(mm ²)
1612290-1 1612290-2	0.64 Receptacle (Female Terminal)	CAN	0.22
		CHFUS	0.35
		AVSS/AVSSH/AVSSX	0.3
		AESSX	0.3
2040168-1 2040168-2	0.64 Receptacle L-size (Female Terminal)	AVSS/AVSSH/AVSSX/AESSX/ CHFUS	0.5

Fig.2

<2.3II Terminals>

The 2.3II Terminal does not have handling in our company.

Please inquire details of our business.

1.3 Others

0.64/2.3II Dummy Plug and Wire Seal do not have handling in our company.

Please inquire details of our business.

<Terminal extraction jig>

- 0.64 Terminals : 3070000(SUMITOMO No.)
- 2.3II Terminals : Precision screwdriver(1.2mm~1.6mm)

1.4 Components View

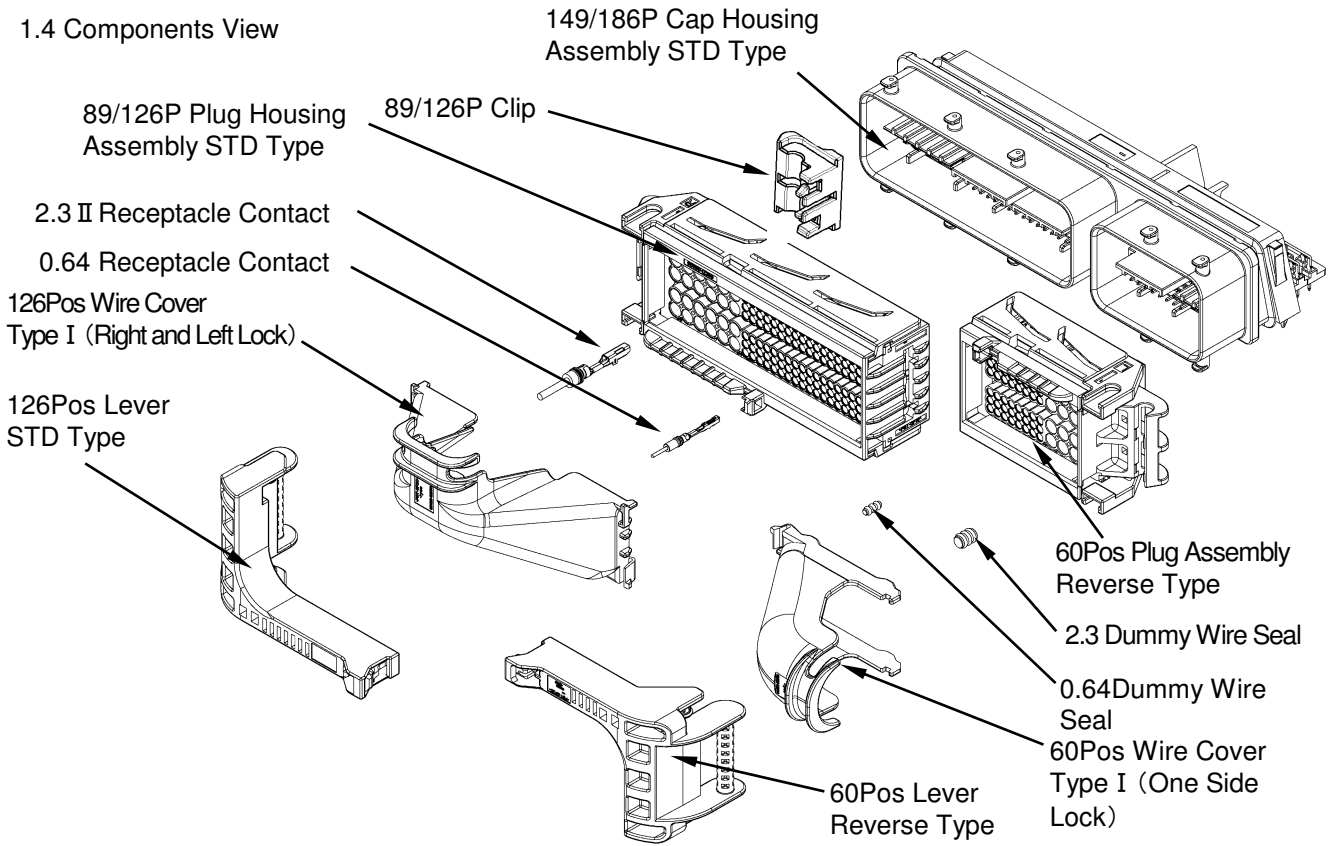

Fig.3

2. Customer Receiving Inspection

We conduct inspections according to our quality control regulations to maintain an over all lot control. In addition, the customers should conduct receiving inspections based on the specific customer drawings.

3. Storage and Carrying

3.1 Terminal

- (1) Avoid leaving or carrying the terminal reel in an open area without wrapping it in proper material.
- (2) Do not lift up and carry the terminal reel by gripping one the side of reel, this may result in damage to the reel, and terminals before use. (See Fig.4)

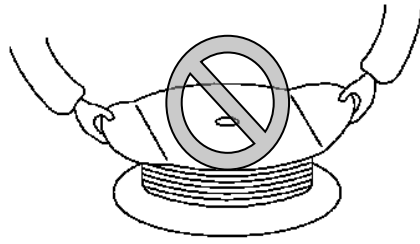

Do not lift up laterally

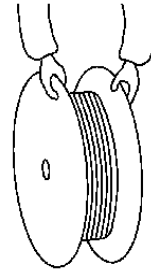

Acceptable

Fig.5

- (3) Avoid storing the terminal reel in a moist or dusty place. Stock the reel in a comparatively dry and clean place (5~35°C, 45~85%RH) away from direct sunlight.
- (4) When removing the terminal reel from the machine, fasten the end of terminal strip onto the edge of the reel with use of proper string or wire. (See Fig.5)

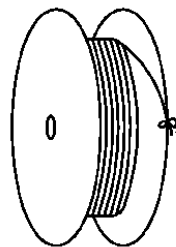

Tie strip end with a wire neatly

Fig.6

3.2 Housing

- (1) Avoid storing the terminal reel in a moist or dusty place. Stock the reel in a comparatively dry and clean place (5~35°C, 45~85%RH) away from direct sunlight.
- (2) Avoid leaving or carrying the terminal reel in an open area without wrapping it in proper material.
- (3) Do not drop or shock the housing when carrying it.

4. Fixing Housing and PC Board

4.1 Male Connector

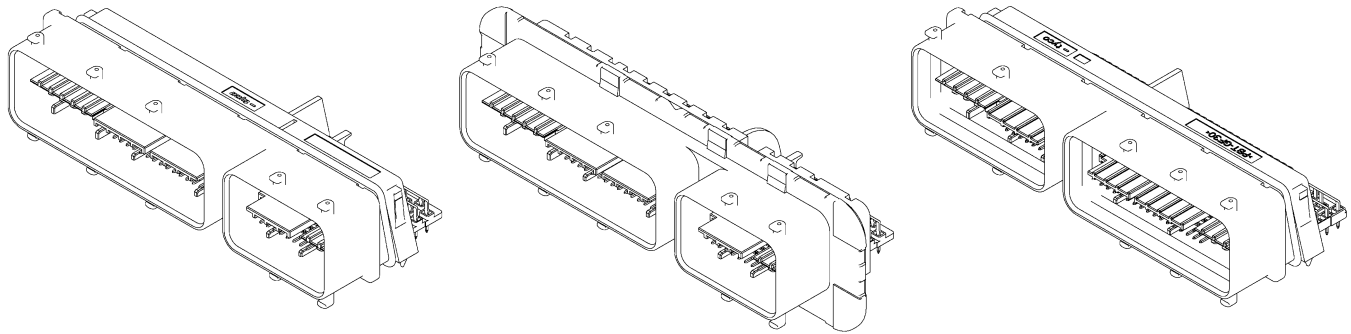

149/186Pos Cap Housing
Assembly STD Type

186Pos Cap Housing
Assembly Flange Type

186Pos Cap Housing
Assembly THS Type

Fig.7

4.2 Fixing Housing and PC Board in state with Tine Plate

Insert the terminal of the male connector into the holes of PC Board. Then after fixing the housing and the board with temporary snap fixing, solder the terminals.

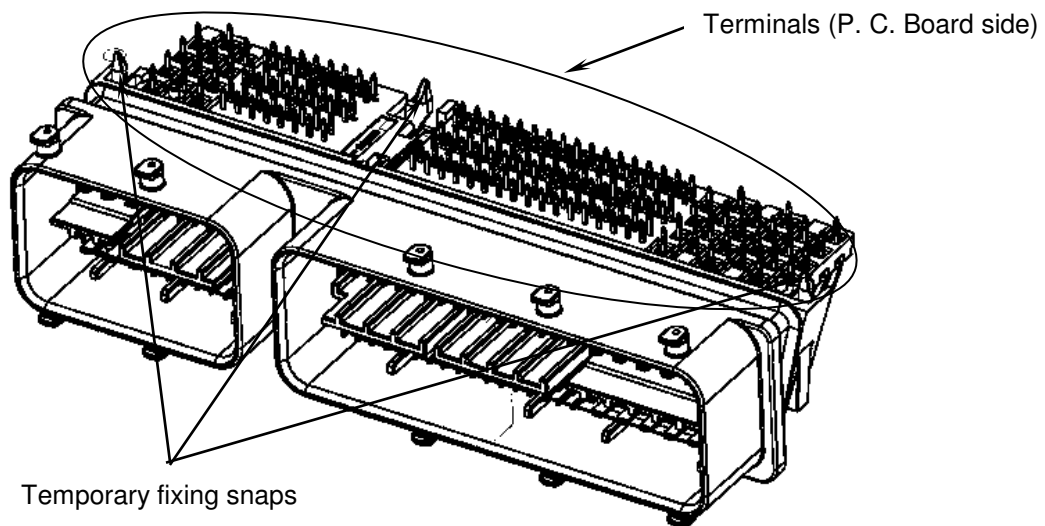

Fig. 8

NOTE Do not deform the terminal (PC Board side); otherwise the male connector can not be fixed on the PC Board.

NOTE In all the processes, both sides (mating side and solder side) of the terminal and the housing must not be damaged or deformed by the operation. No foreign substance is permissible in the mating area and case seal area.

NOTE See the customer drawing for the PC Board dimension.

NOTE Please note that it is not of transform and damage of the temporary fixing snap when you temporarily stop the substrate to the snap for a temporary fixing.

NOTE No discoloration or deformation should be caused by the heat of soldering.

4.3 Installation work to PC Board as removed Tine Plate (Example of reference)

(1) Please make Tine Plate upward like fig.9, and install the Male Connector in substrate made of installation Jig.

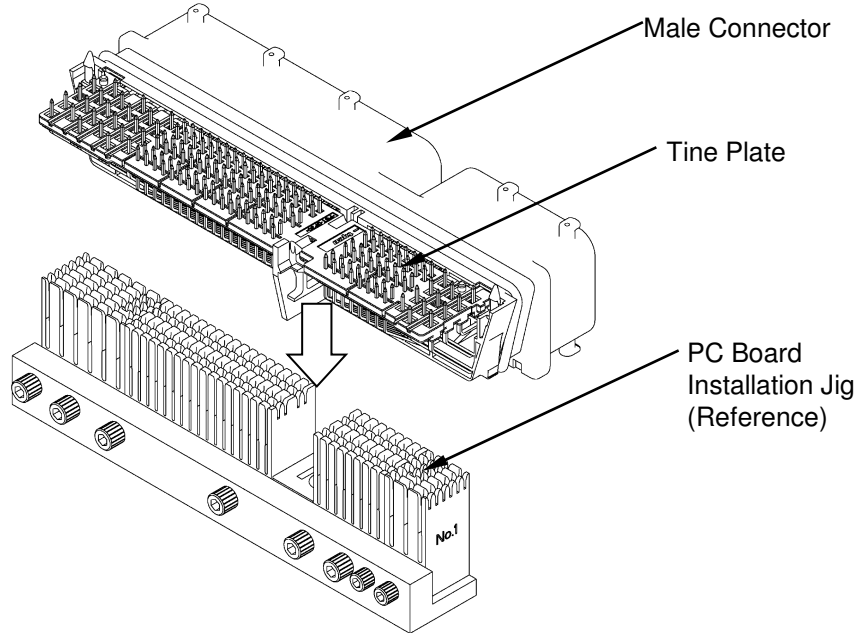

Fig. 9

NOTE Do not deform the terminal when Tine Plate is removed.

(2) Detach Tine Plate after installing Male Connector on Jig.

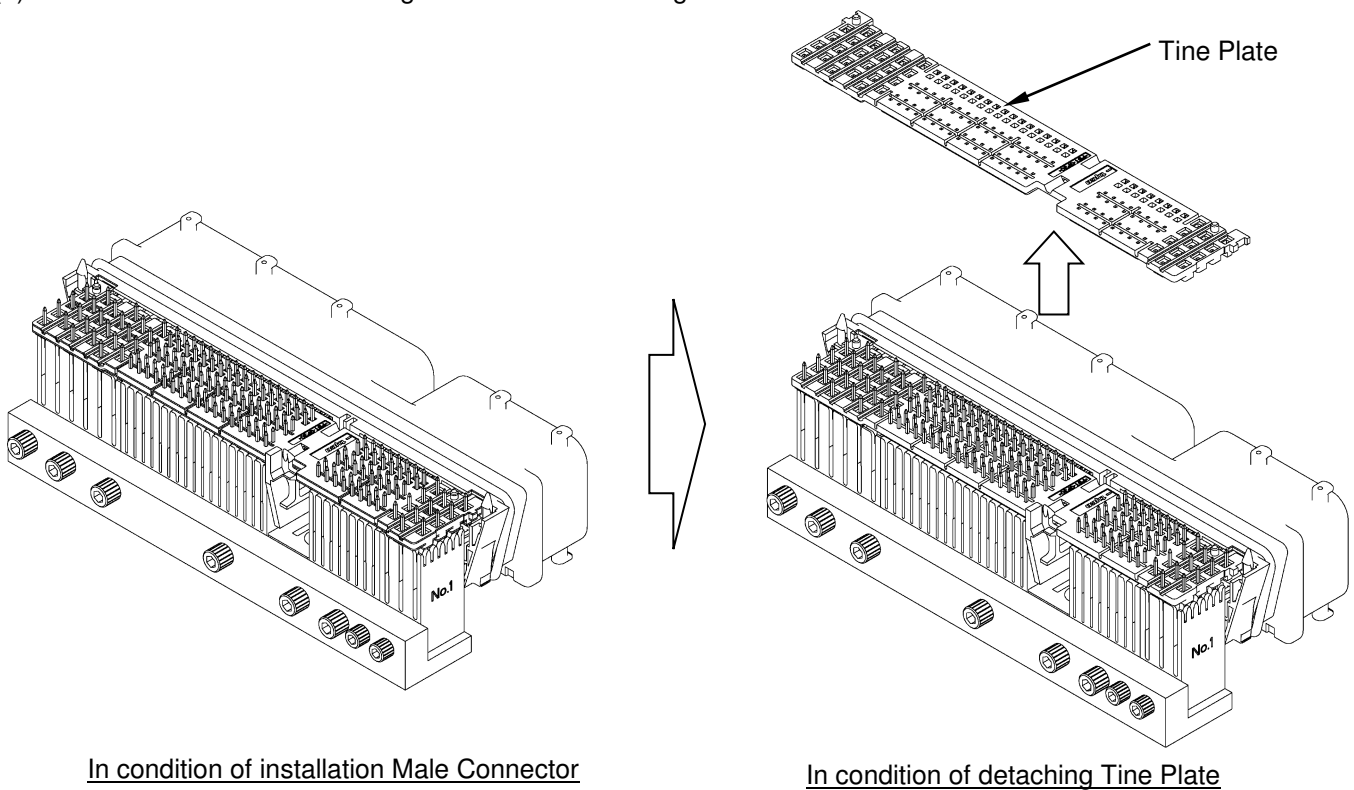

Fig. 10

NOTE Do not deform the terminal when Tine Plate is removed.

(3) Confirm the insertion the Terminal of the Male Connector into the holes of PC Board after detaching Tine Plate.

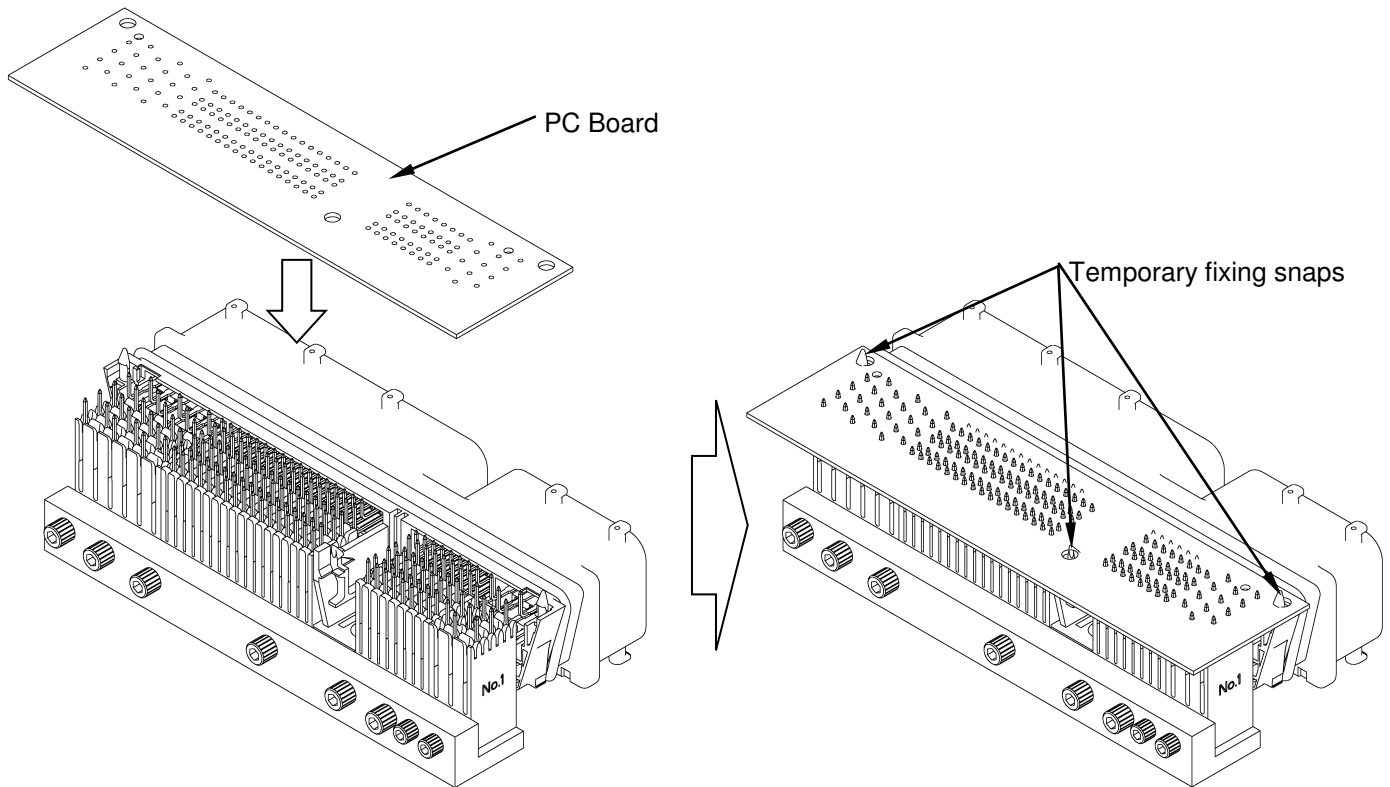

Fig. 11

NOTE Please note that it is not of transform and damage of the temporary fixing snap when you temporarily stop the substrate to the snap for a temporary fixing.

NOTE See the customer drawing for the PC Board dimension.

NOTE Please confirm the thing that the Terminal the hole of PC Board when PC Board is installed.

(4) Please remove from Jig, and soldering the Male Connector after installing the PC Board in the Male Connector.

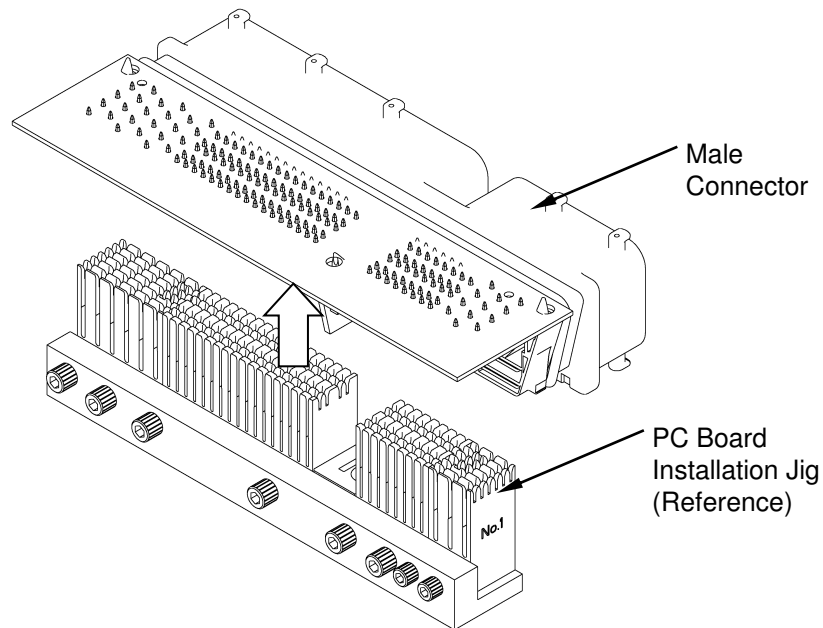

Fig. 12

NOTE Be careful not to catch the Terminal on Jig when Tine Plate is removed. Moreover, the Terminal must not come off from the PC Board's hole.

NOTE No discoloration or deformation should be caused by the heat of soldering.

NOTE In all the processes, both sides (mating side and solder side) of the terminal and the housing must not be damaged or deformed by the operation. No foreign substance

is permissible in the mating area and case seal area.

5. Crimping Operation

Any crimping of terminals must be performed by using appropriate TE tools according to the applicable Instruction Sheet and Specification.

5.1 Wires

5.1.1 Applicable Wires

See Fig.2 .

5.1.2 Notes for Stripping of Wire End

Wire end must be stripped without nick, cutoff, or damage of wire strands.

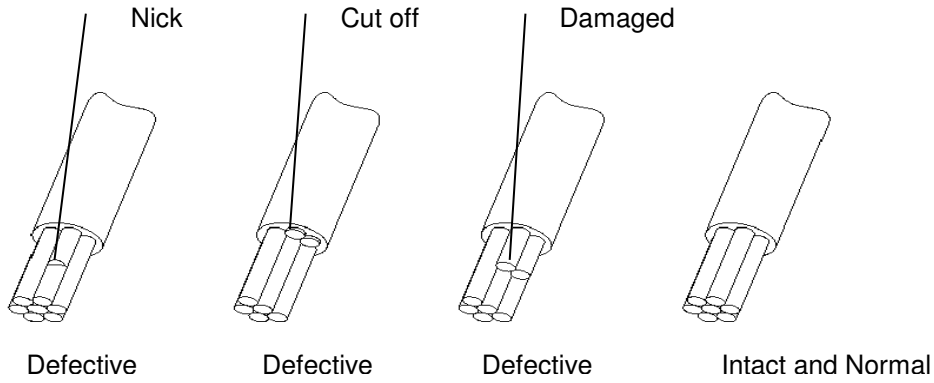

Fig.13

5.2 Operation of Crimping Machine

See the following instruction sheet for automatic terminating machine.

0.64 Receptacle	114-5336
2.3 II Receptacle	

5.3 Storage and Handling of Crimped Products

- (1) Store the products in a clean, dry area, cover with proper sheet or paper when placed in an open area until the next day.
- (2) Crimped leads should be processed in bundles of less than 100 pieces. Take care of the tangle and damage on the products.
- (3) Avoid stacking and piling up the in-process products in large volume. Terminal failure and fall of retention force occur by deformation of the terminal.

6. Harness Making

6.1 Female Connector, Wire Cover and Lever, Clip

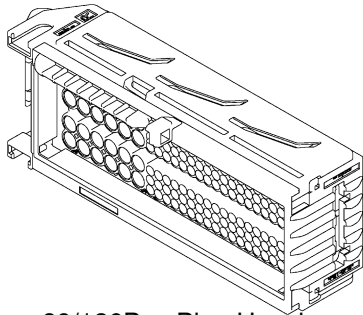

89/126Pos Plug Housing Assembly Reverse Type

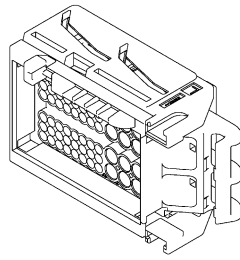

60Pos Plug Housing Assembly Reverse Type

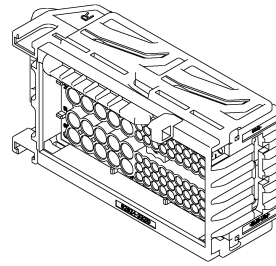

74Pos Plug Housing Assembly THS Reverse Type

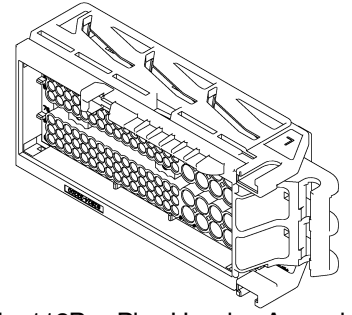

112Pos Plug Housing Assembly THS Reverse Type

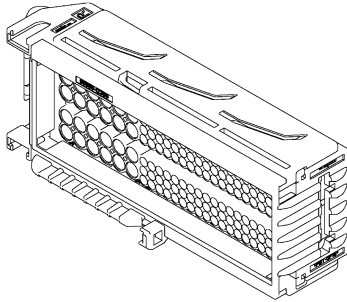

89/126Pos Plug Housing Assembly STD Type

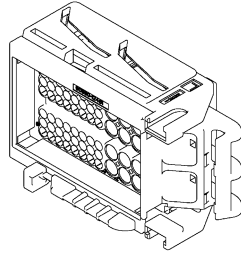

60Pos Plug Housing Assembly STD Type

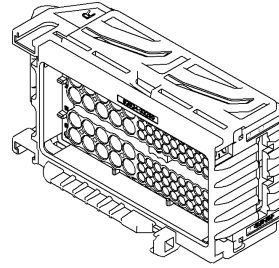

74Pos Plug Housing Assembly THS STD Type

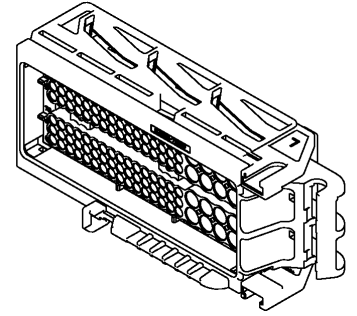

112Pos Plug Housing Assembly THS STD Type

Fig.14 (To be continued)

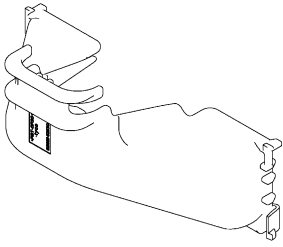

126Pos Wire Cover Type I

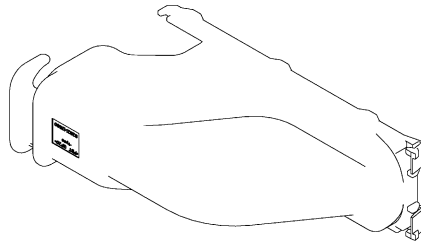

126Pos Wire Cover Type II

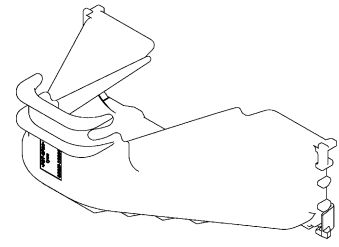

126Pos Wire Cover Type III

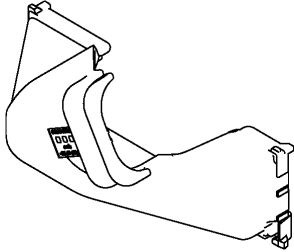

89Pos Wire Cover Type V

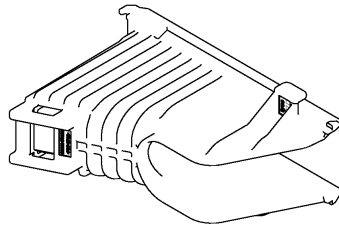

126Pos Wire Cover Type VI

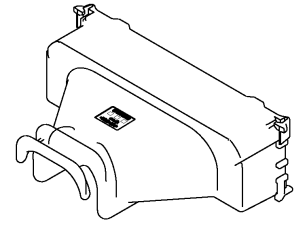

126Pos Wire Cover Type VII

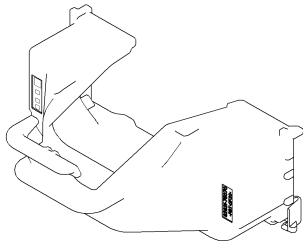

112Pos Wire Cover THS Type I

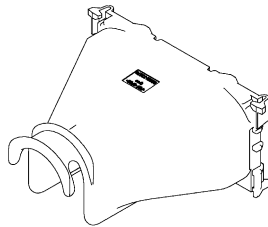

74Pos Wire Cover THS Type I

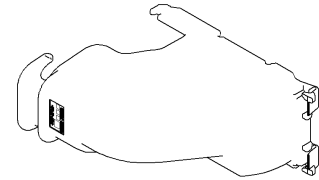

74Pos Wire Cover THS Type II

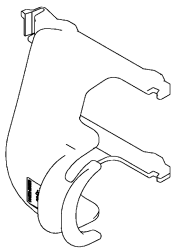

60Pos Wire Cover Type I

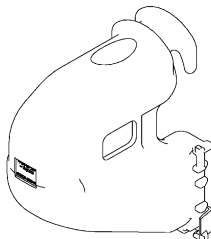

60Pos Wire Cover Type II

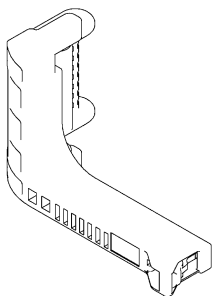

126Pos Lever STD Type

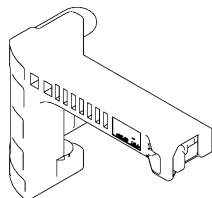

126Pos Lever Reverse Type

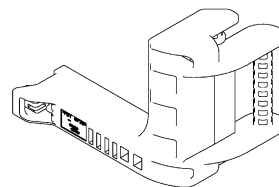

60Pos Lever STD Type

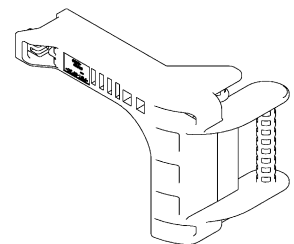

60Pos Lever Reverse Type

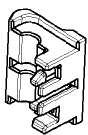

89/126Pos Clip

Fig.14 (End)

6.2 Procedure for Female Terminal Insertion into Housing

- (1) Confirm the retainer is in pre-assembled condition. See para.6.3. The terminal can not be inserted in final lock condition.

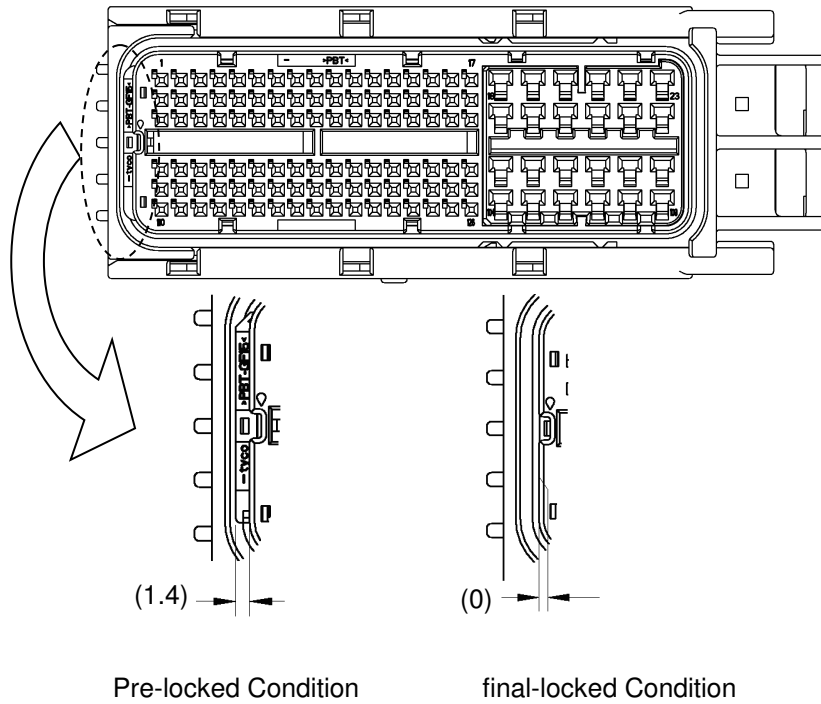

Fig.15

- (2) Confirm type of plating on the terminal. It must be the same type of plating on the female terminal and on the male terminal. The type of plating can be seen on the customer drawing.

NOTE Should not connect the terminals between different types.

- (3) Confirm the terminal size (0.64, 2.3II). The cavity size of housing can be identified by the shape of cavities. See the customer drawings to know the construction of cavities.

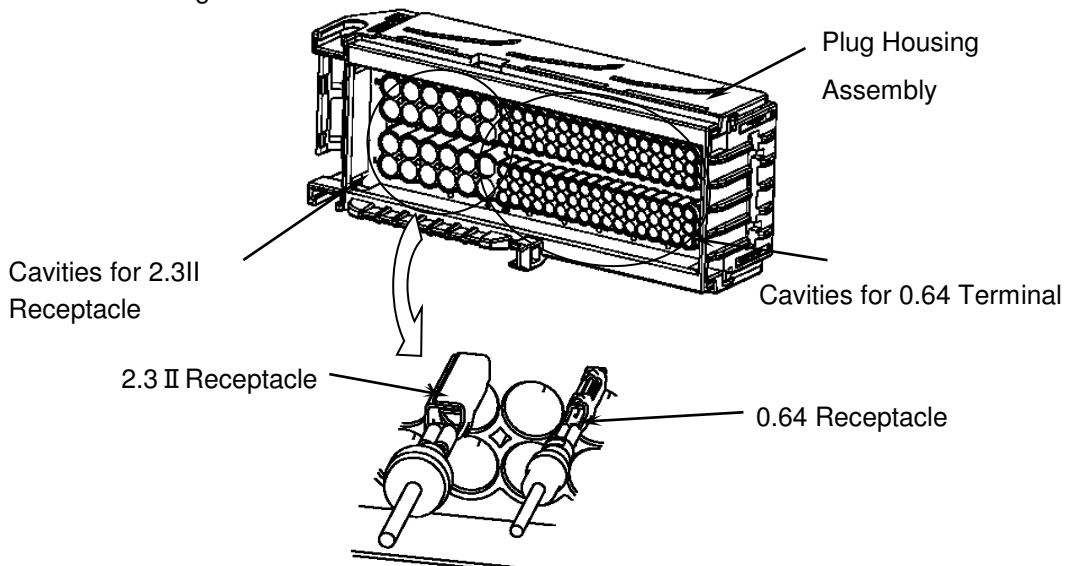

Fig.16

- (4) 79/89/126 pos turn the lever bearing to left as shown in Fig.17, and 60 pos insert the crimping side of 0.64/2.3II Receptacle terminal with the lever bearing turned to right and insert terminal into the housing.
 The insertion is finished when housing lance is locked and the terminal can not be more inserted.
 If harness has any blanked cavities, dummy rubber plugs must be inserted.

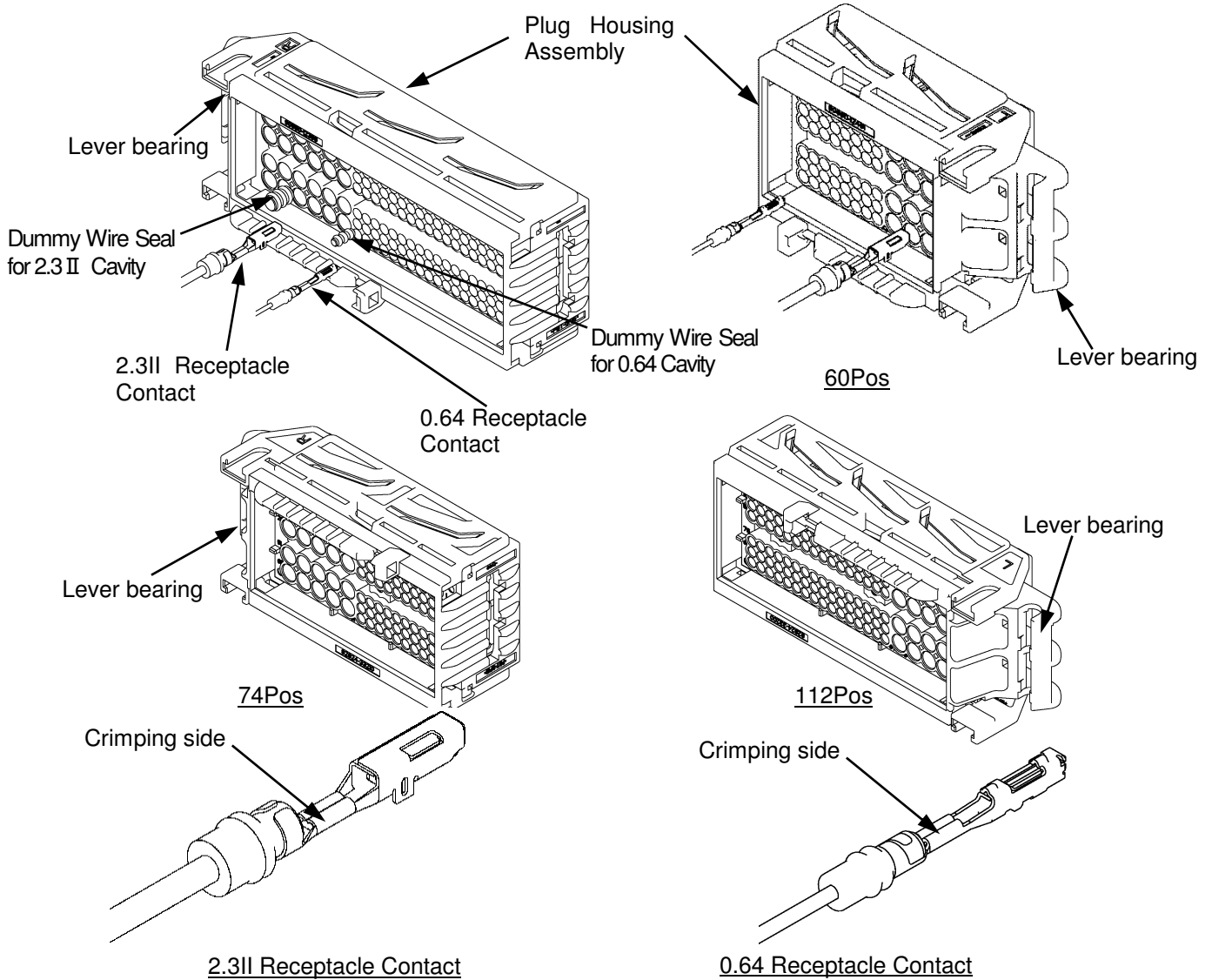

Fig.17

NOTE Hold the wire so as not to generate the compression buckling of the transformation as you insert the terminal into the plug housing cavity.

- (5) By pulling the terminal by 20N MAX, check to make sure that the terminal can not be withdrawn.
 Please lightly push the terminal again after confirming the terminal pull, and make the clearance position into the terminal and housing lance.
- (6) Please insert Dummy Wire Seal in the position in which 0~1mm goes out of the upper surface of the cavity.

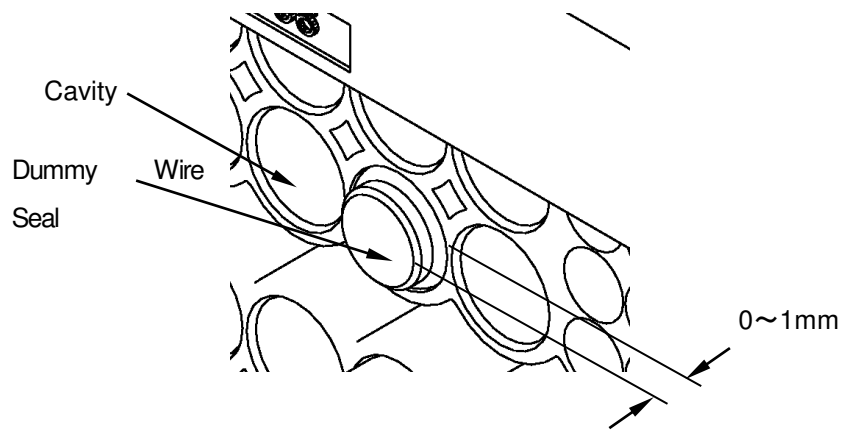

Fig.18

NOTE

Please use 1 piece cavity when you use Dummy Wire Seal.
The retainer might not close when two or more pieces are put.

6.3 Retainer (Final Lock) Operation

- (1) After insertion of all of the terminals, press the retainer for final lock condition. The final lock operation is finished by confirmation that the retainer is kept in the final condition by the 2 projections.

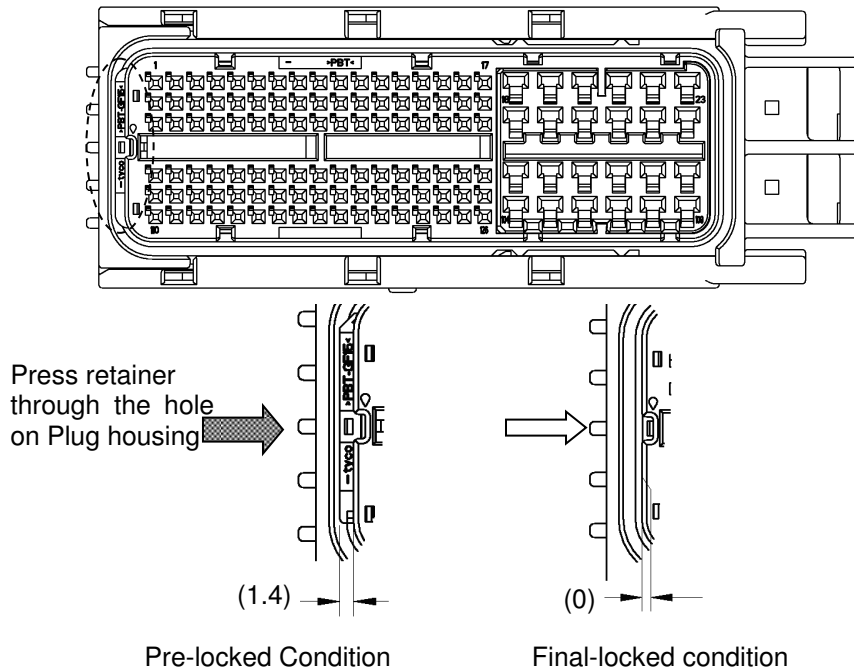

Fig.19

- (2) The double lock operation can not be completed if there are any half inserted terminals. When the retainer can not be pressed to the final condition, do not press by force, find the half inserted terminal, and insert it to proper position. See para.6.1.

6.4 The notice regarding semi- installing inspection

6.4.1 The female terminal semi- installing inspection with appearance

- (1) Semi- installing inspection of the female terminal is possible with the fact that floating occurs at the time of retainer installing job.

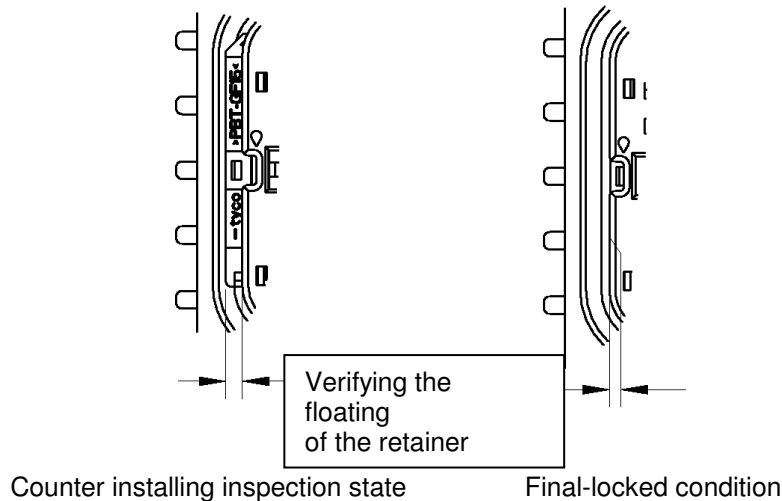

Fig.20

6.4.2 The female terminal semi- installing inspection with the increase of the retainer operation load

- (1) The retainer operation load at the time of female terminal semi- installing it is the load above approximately 2 times the normal time vis-a-vis the retainer operation load, semi- installing inspection is possible.

6.4.3 Prevention of semi- installing with female terminal arrangement state

- (1) The peripheral terminal is less crowded terminal not yet installing (and when the cavity) it is state, please verify that primary person in charge stopping catches.

NOTE Semi-installing inspection cannot be detected by the fact that draft and float generating when there are some gaps around the peripheral terminal. Please verify that primary person in charge stopping catches.

NOTE When abnormality is discovered, please be sure to exchange with the new item.

6.5 Wire cover installation and removal operations

6.5.1 126Pos Type I /TypeIII/TypeVII, 89Pos Type V , 112Pos Type I ,74Pos Type I , 60Pos TYPE- II Wire Cover(Right and Left Lock)

(1) Set of wire cover

When harness installed operations and installation of the retainer(final lock condition) is completed, the wire cover like the below figure, from above is installed to the female housing. Until non- displacement lock section 2 places and lock section 2 places are fixed to the female housing, please install to the direction of the arrow. When installing in order not to catch the wire to the cover, please note.

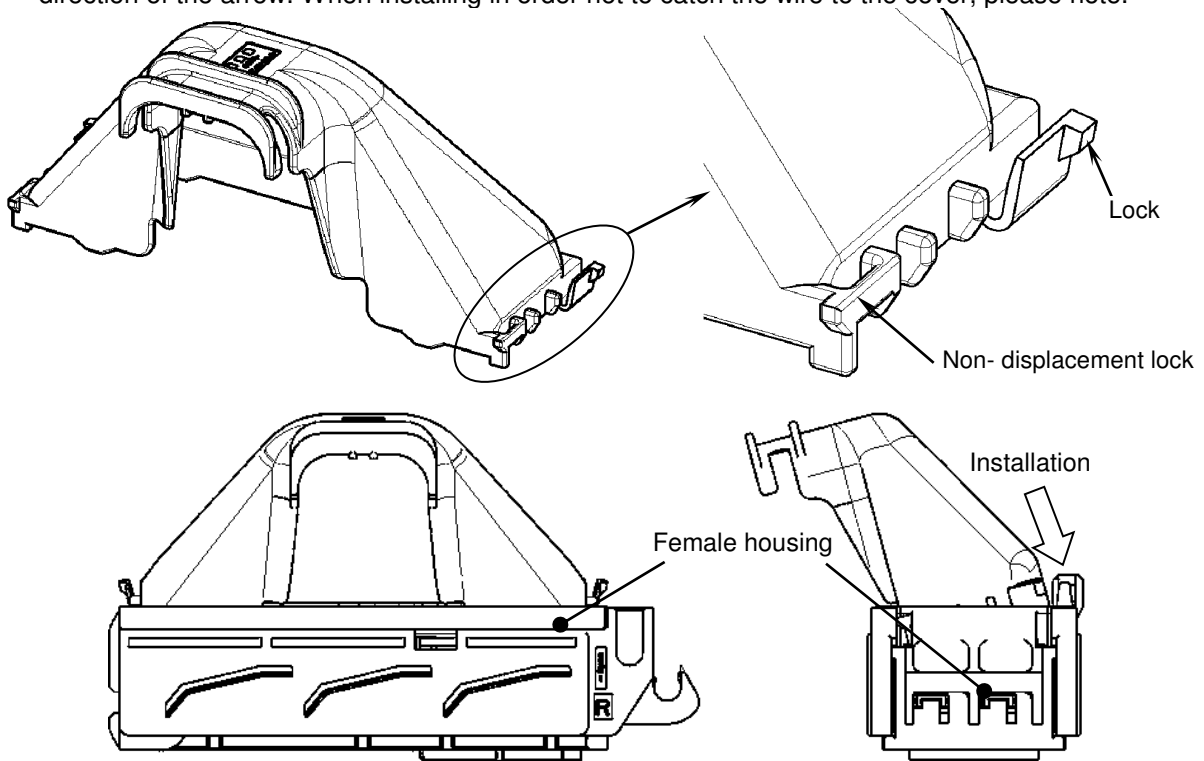

126Pos Wire Cover
Fig.21

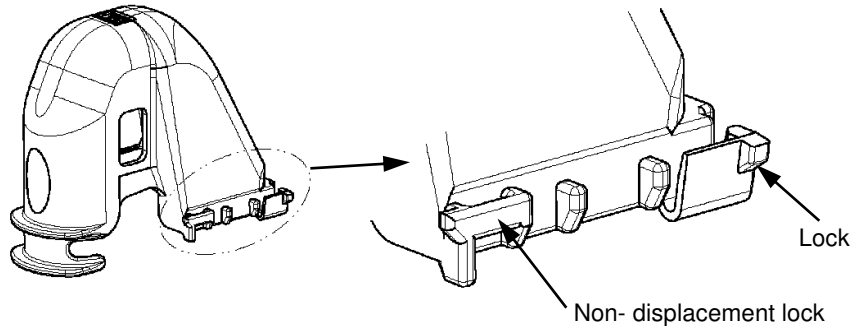

60Pos TYPE- II Wire Cover
Fig.22

※It is work similar as for 74Pos Type I and 126Pos TypeIII/Type VII. 89Pos Type V , 112Pos Type I

(2) If the lock of the wire cover like of the below figure the lock on left and right , and the non- displacement lock of the cover is fitted to the female housing, installing the wire cover is completion. Please verify that the left and right lock has mated.

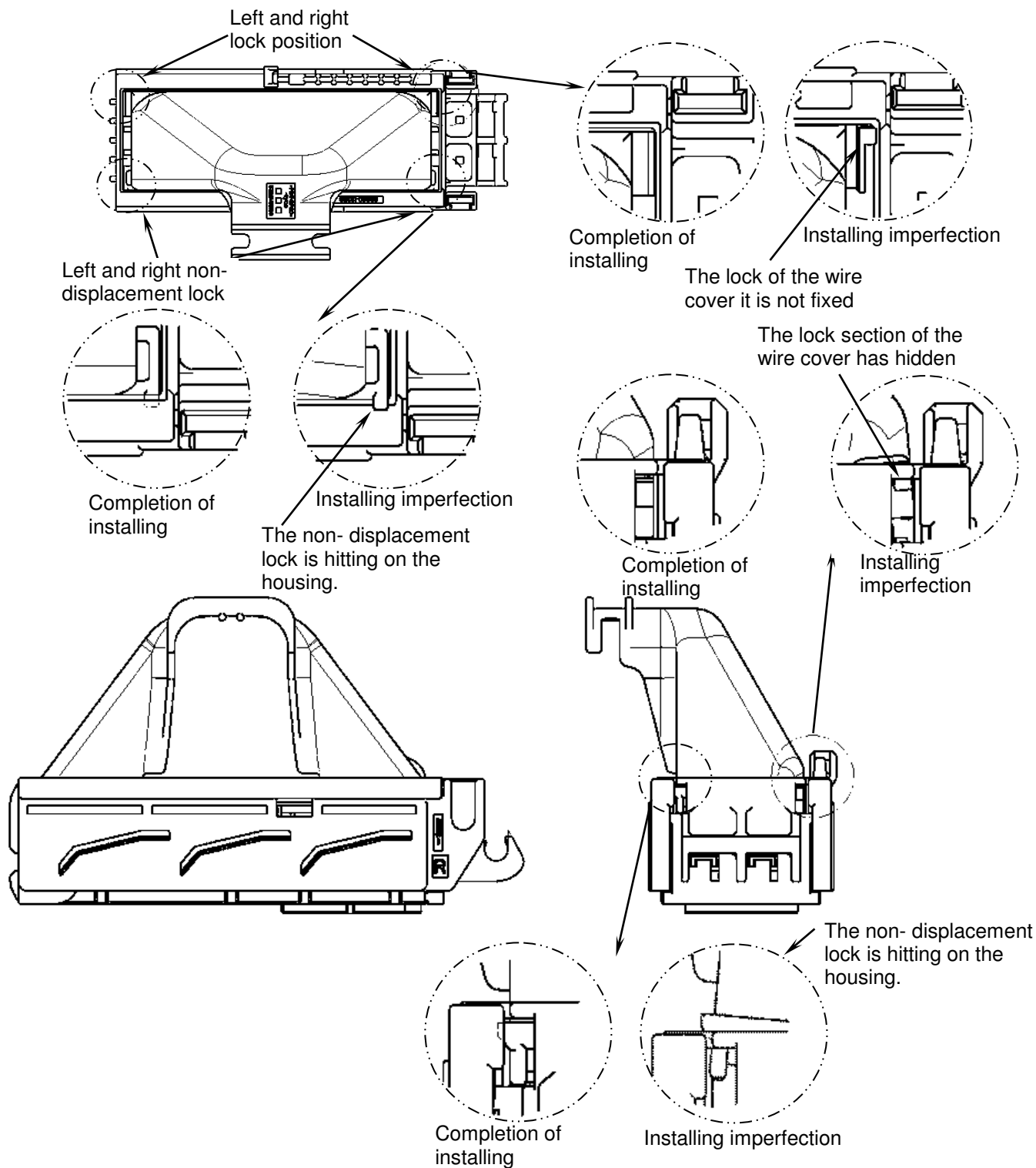

Fig.23

- (3) The removal of the wire cover, while pushing the lock on left and right of the cover to direction of the arrow, to pull up the lock section to on, please unlock the lock.

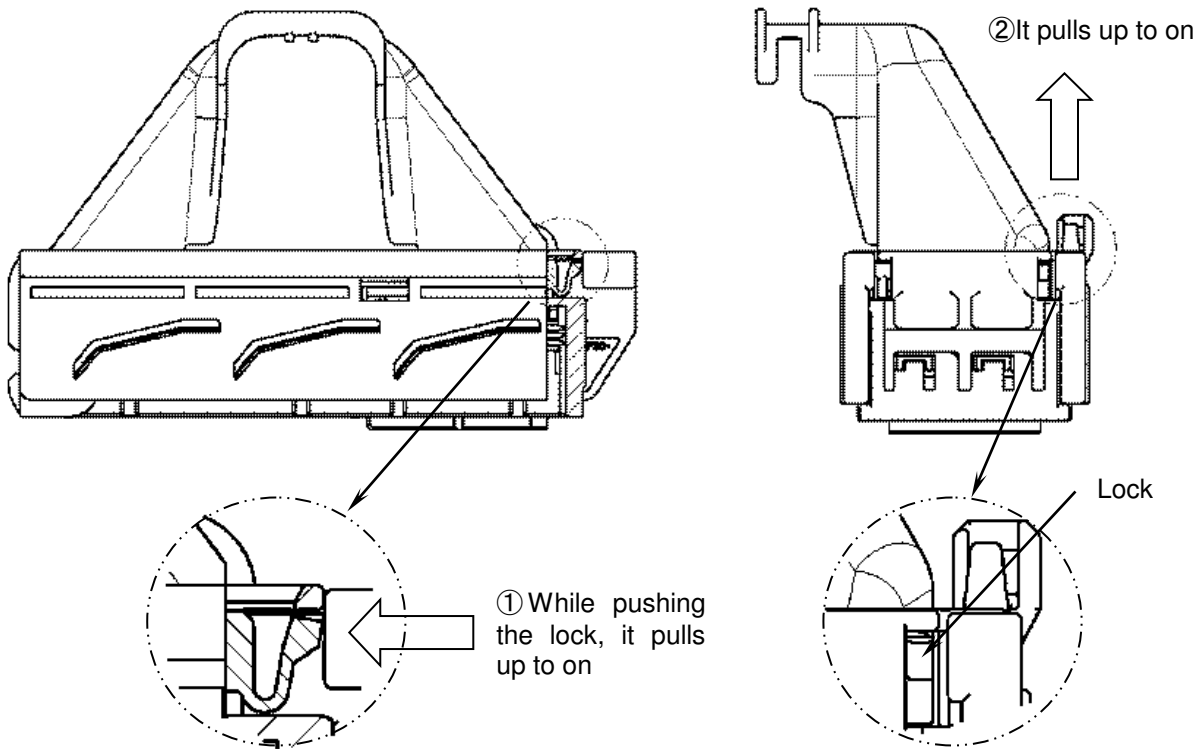

Fig.24

- (4) When it unlocks the lock of the wire cover and passes through from the female housing please pull out to direction of the arrow.

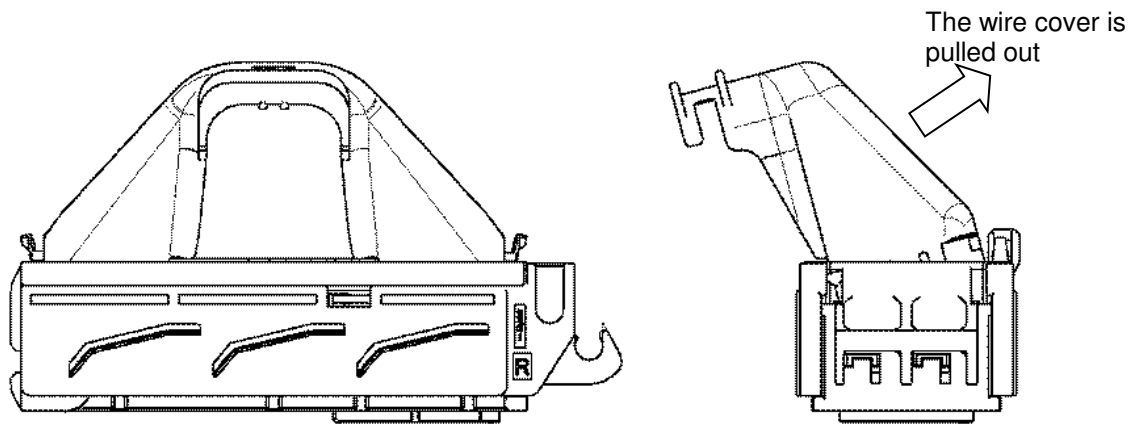
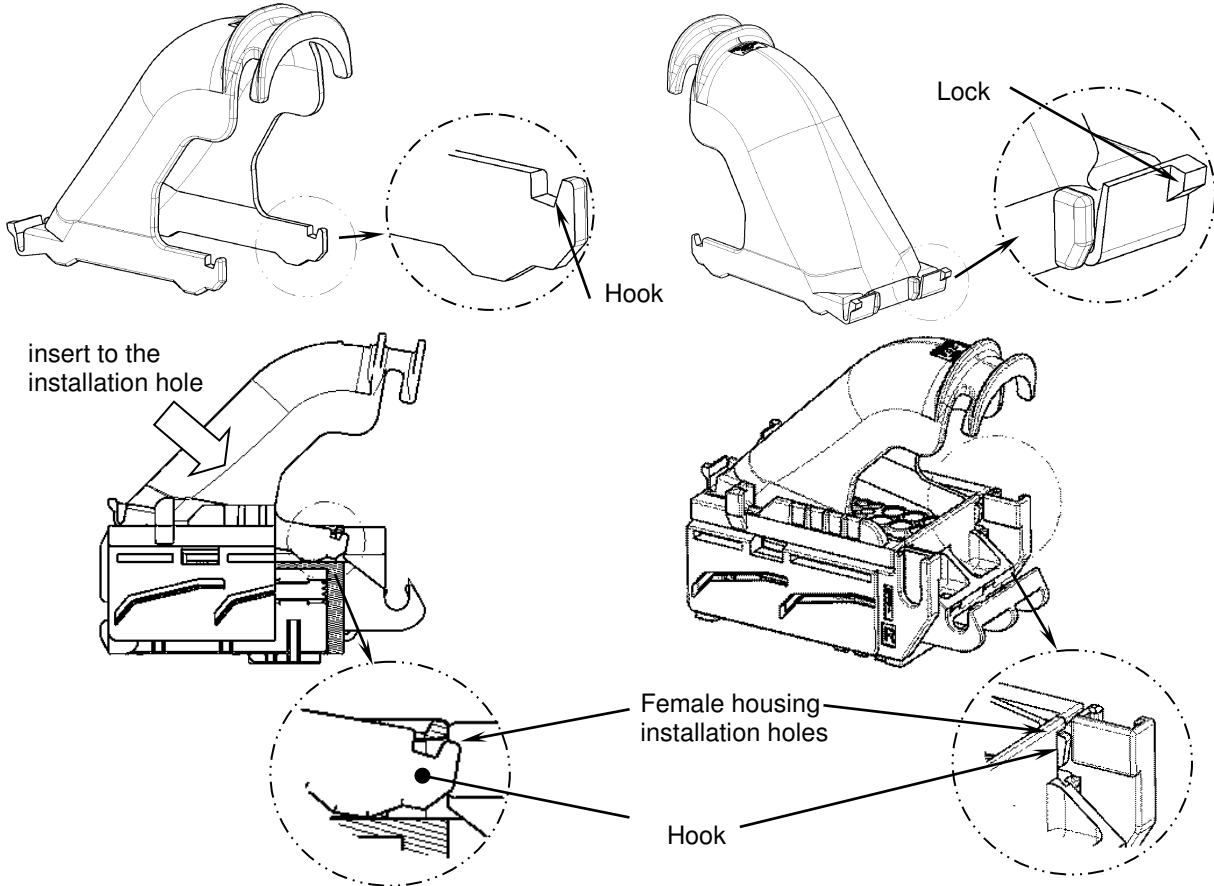

Fig.25

6.5.2 60Pos Type I ,126Pos TYPE II /TYPE VI , 74Pos Type II Wire Cover(One Side Lock)

(1) Set of wire cover

When harness installed operations and installation of the retainer (final lock condition) is completed, the wire cover like the below figure, the hook is inserted to the installation holes of the female housing.



60Pos Wire Cover Type I
Fig.26

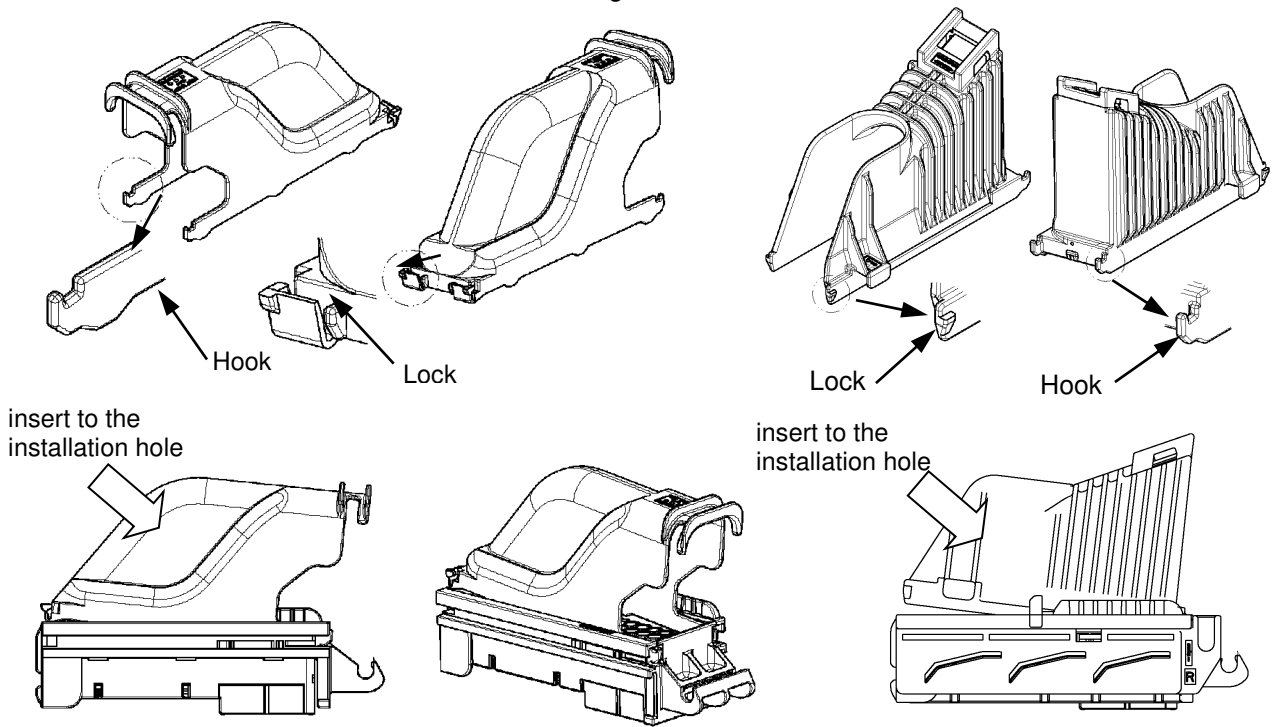

126Pos Wire Cover Type II

126Pos Wire Cover Type VI

Fig.27

※It is work similar as for 74Pos Type II

(2) While hooking the hook of the wire cover to the installation holes, please install the lock to direction of the arrow. When installing in order not to catch the wire to the cover, please note.

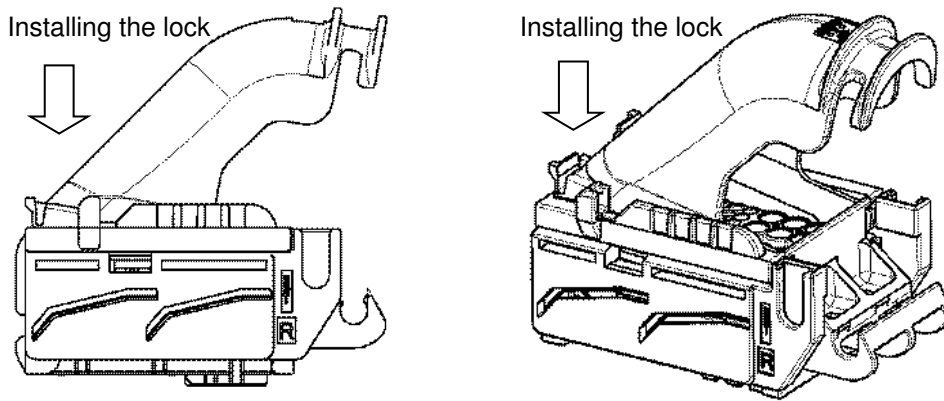

Fig.28

(3) If the lock of the wire cover like of the below figure the lock of the cover is fitted to the female housing, installing the wire cover is completion. Please verify that the left and right lock has mated.

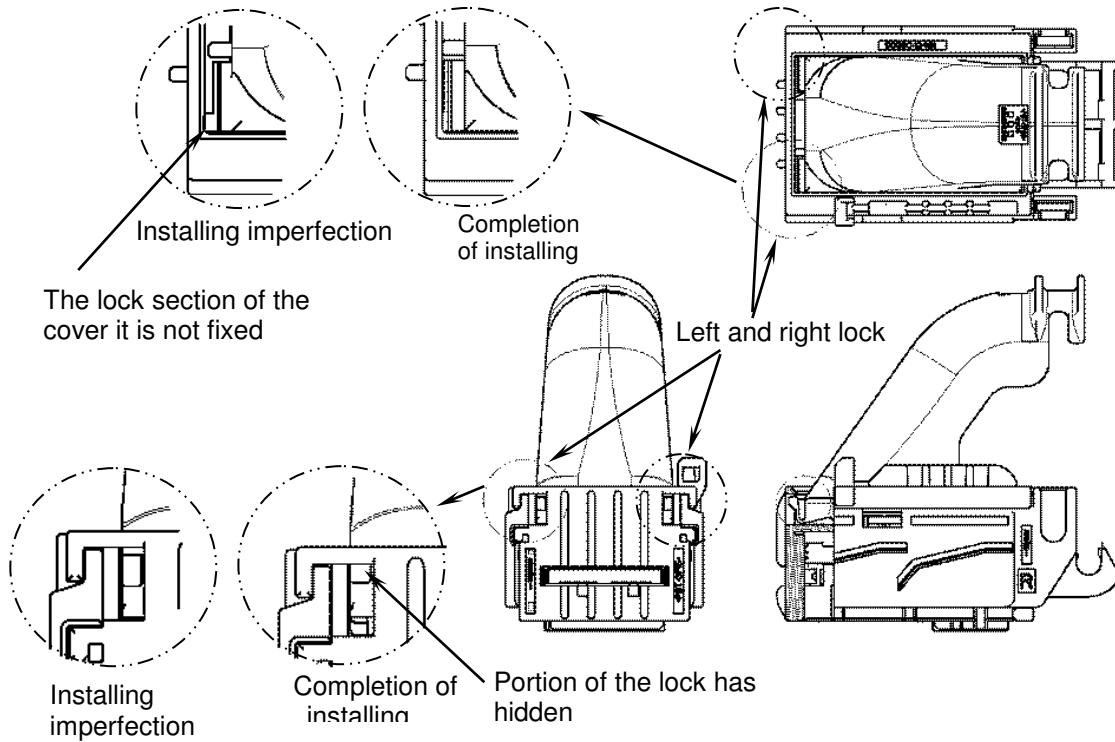

Fig.29

(4) The removal of the wire cover, while pushing the lock on left and right of the cover to direction of the arrow, to pull up the lock to on, please unlock the lock.

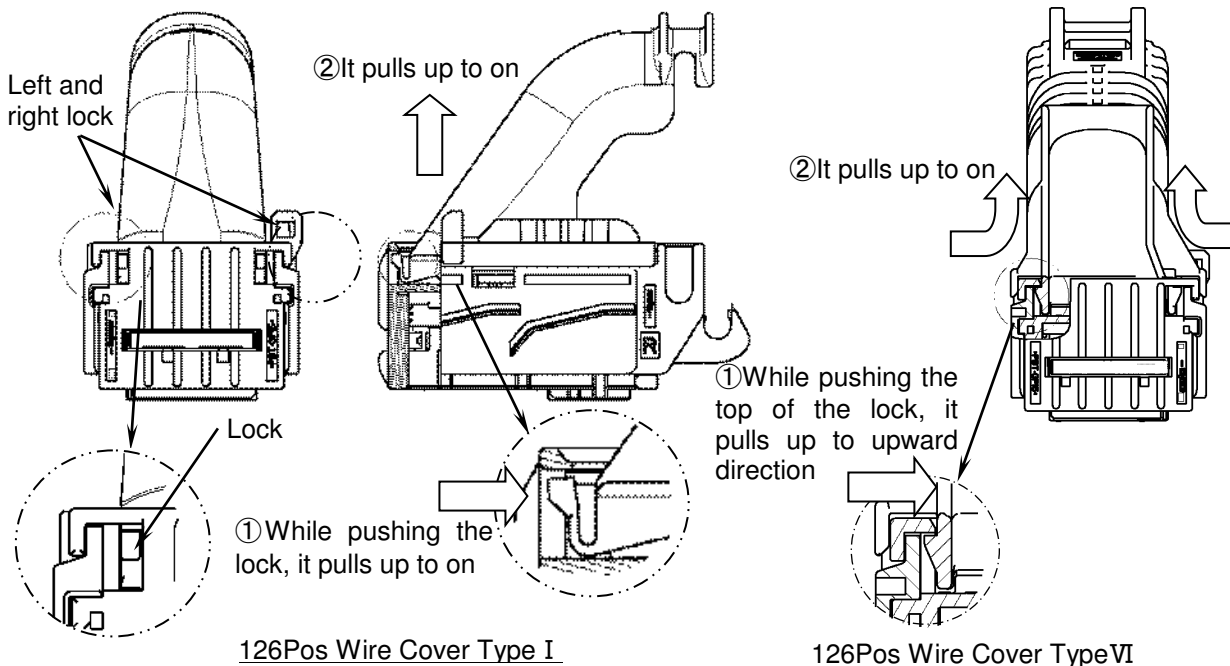

Fig.30

(5) When it unlocks the lock of the wire cover and passes through from the female housing in order for the hook not to be caught, please pull out to direction of the arrow.

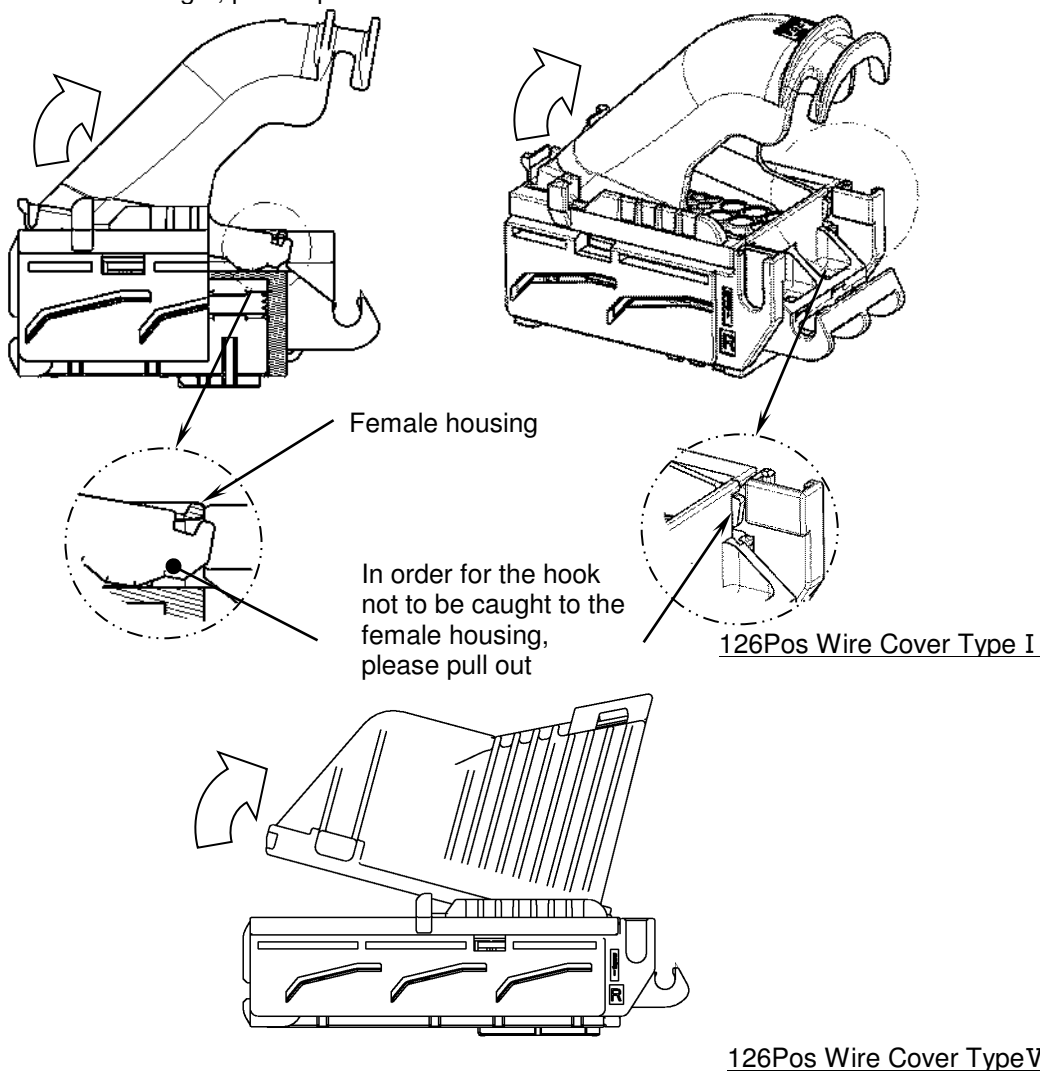

Fig.31

6.6 Lever Fitting Operation

(1) Confirming Slider Position

The slider rough sketch position (when the slider lock has caught) please verify that it is.

NOTE When the lever is installed when the slider has sprung out there is a possibility of breaking the connector.

NOTE Being to be play in the slider, until it hits to stopper, when you push securely, there is a feel.

NOTE Reference you ask the point of caution when installing the EFI ECU CONNECTOR PLUG ASSY LEVER.

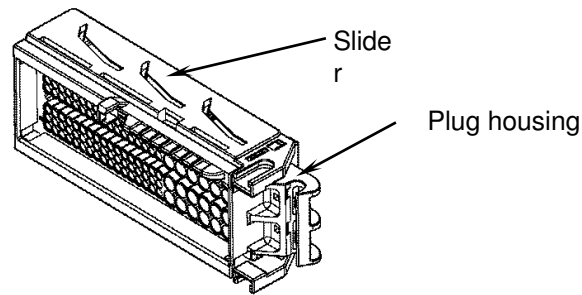

Fig.32

(2) Align of Plug Housing Assembly and Lever

Confirm the direction of Plug Housing Assembly and Lever as the following figure. Fit the shafts on lever into bearing on Plug housing. And then assemble the lever temporarily parallel to Plug Housing.

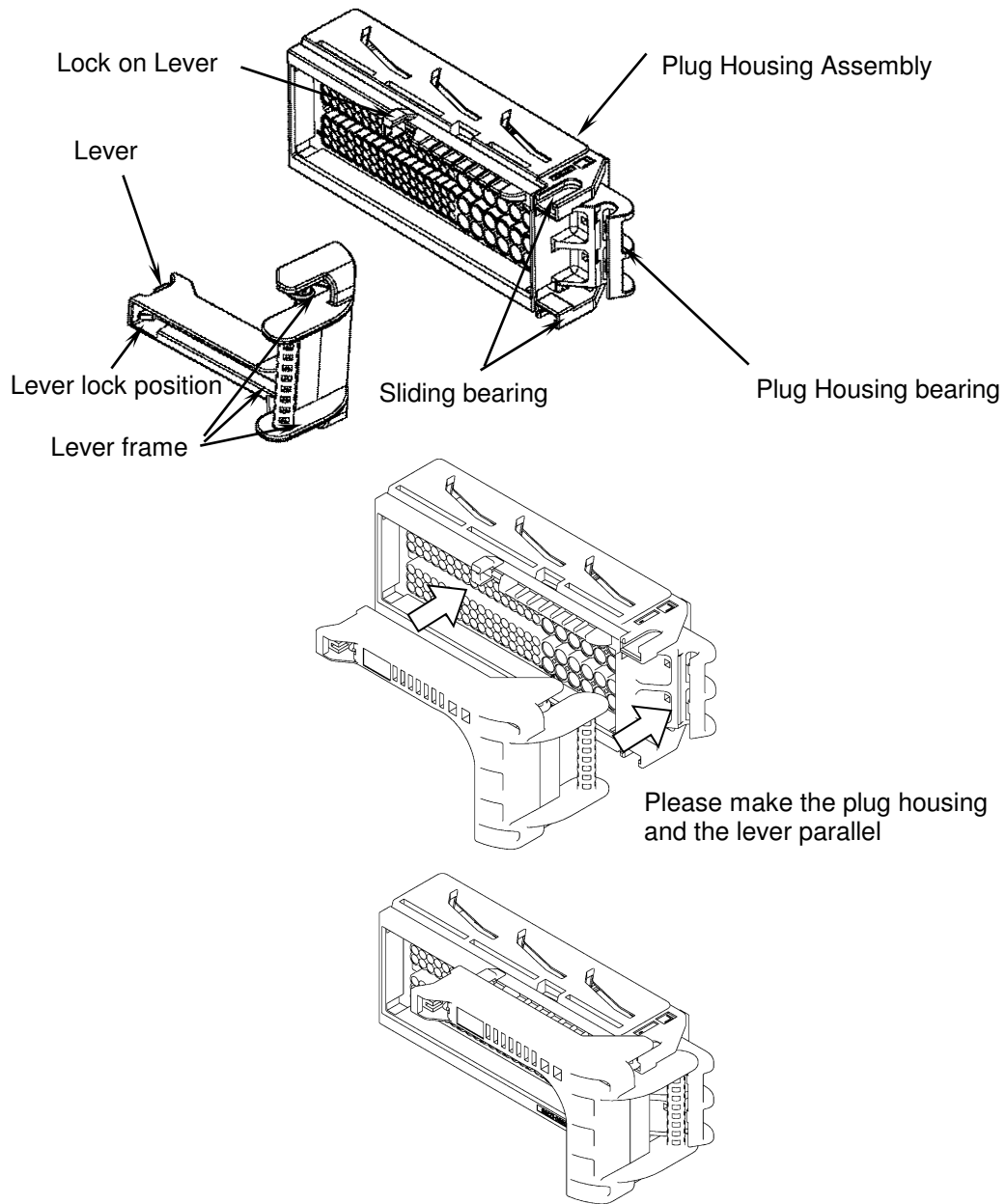

Fig.33

(3) Installation of lever

While supporting the bearing subordinate of the plug housing with the index finger of the both hands, with the thumb of the both hands (you hold the lever with the both hands and until in order to be packed) sound does the lever, please push in.

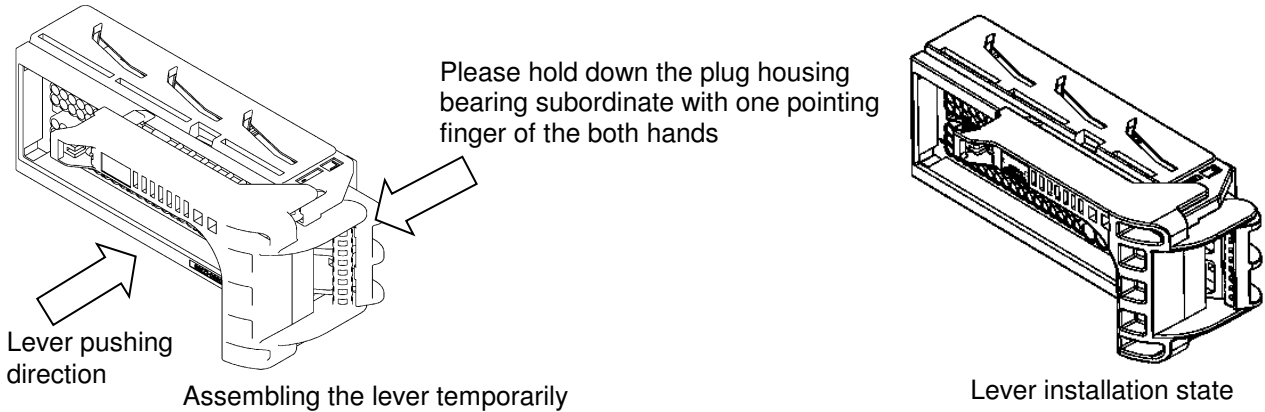

Fig.34

NOTE Please verify that the lever bearing is placed parallel on the bearing of the plug housing.

NOTE As for installation job of the lever we request the job under normal temperature.

6.7 Installation of clip

(1) Please confirm the lever installation work is completed, and the lever is being locked.

NOTE In the state at the previous state of the lever installation, there is a possibility that the installation of the clip becomes hard.

NOTE Reference you ask the point of caution when installing the EFI ECU CONNECTOR PLUG ASSY CLIP.

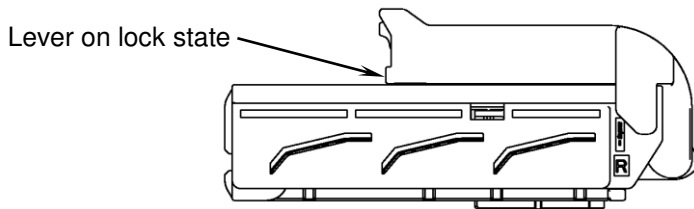

Fig.35

(2) Plug housing Assembly is set to the position of the clip.

Please match the guide hole of plug housing Assembly and the position of the guide pin of the clip, and unite the clip temporarily.

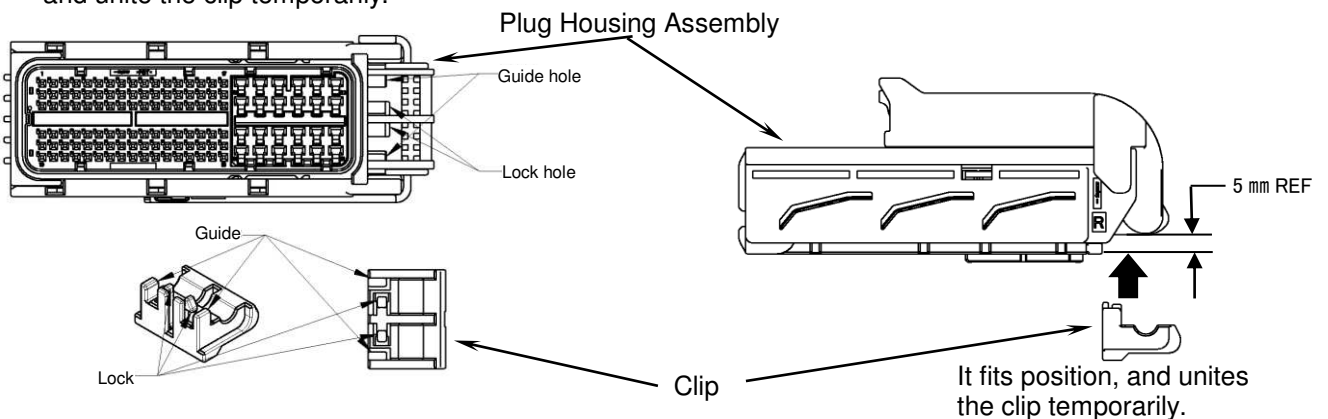

Fig.36

NOTE When abnormality is discovered, please be sure to exchange with the new item.

(3) Installation of clip

Please push the clip below of plug housing Assembly vertically by the thumb of both hands (you hold the clip with the both hands and until in order to be packed).

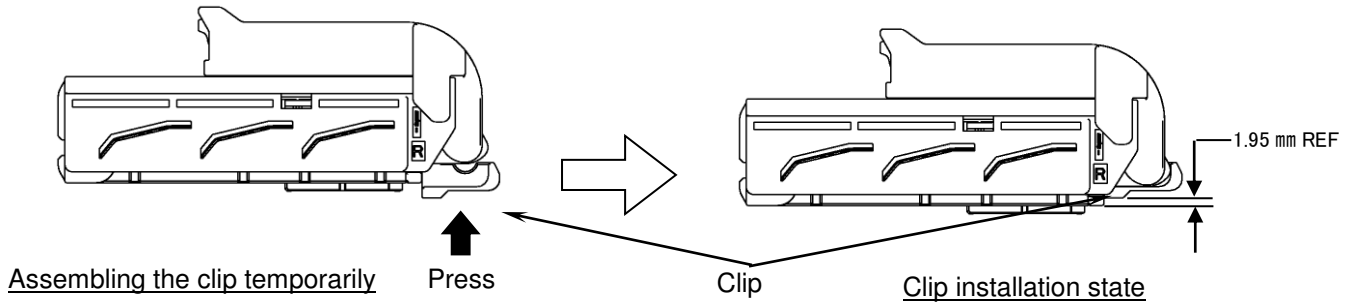

Fig.37

NOTE Please do not add an excessive load when you install the clip. There is a possibility that the connector is damaged.

(4) Installation completion of clip

Please confirm the lock pin of the clip in the lock hole of plug housing Assembly.

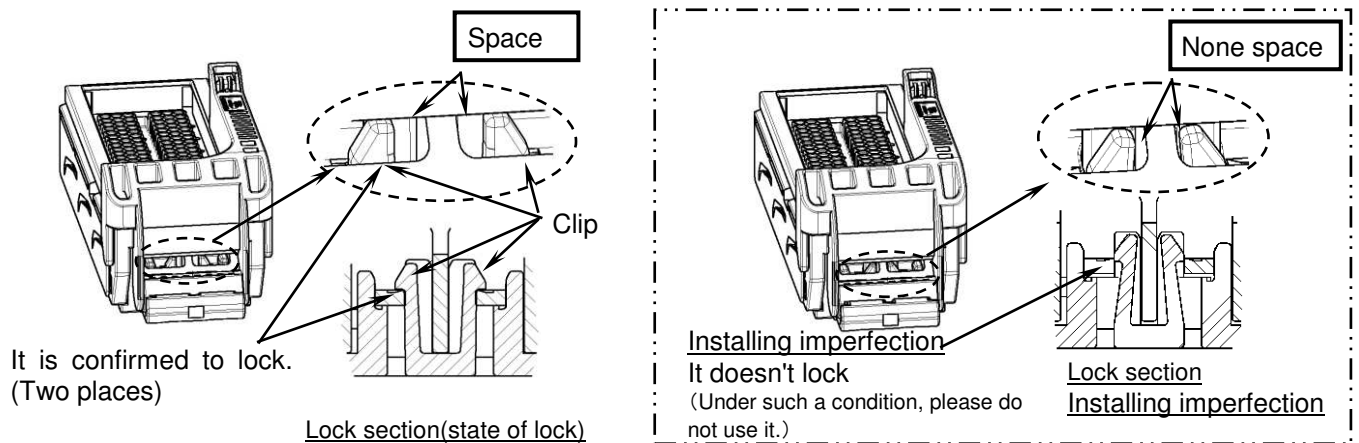

Fig.38

NOTE As for installation job of the clip we request the job under normal temperature.

6.8 Removal operations of clip

(1) Release of lever lock

Please release the lever lock according to para.6.9, and rotate the lever to the place that becomes vertical for the engagement side.

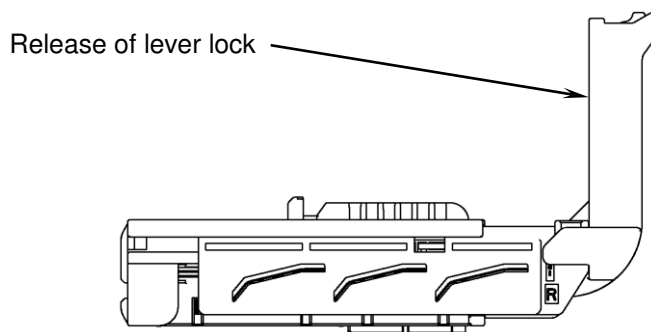

Fig.39

(2) Removal of clip

Please push the hanging part in the point of the lock pin of the clip in the direction of the center of the connector, release the lock, and remove the clip.

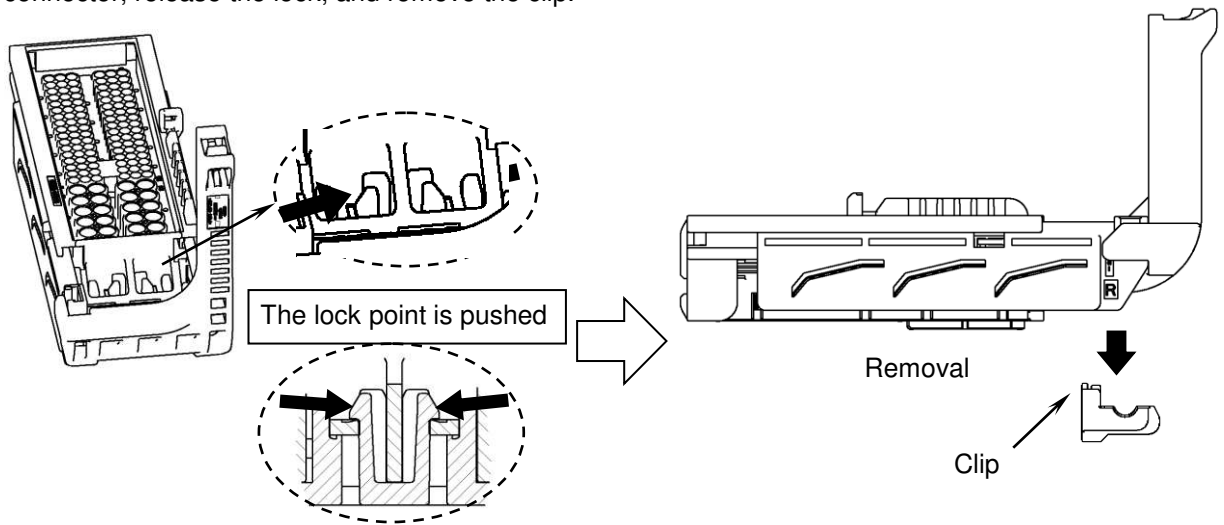

Fig.40

(3) Release removal of clip

Please return it to the state of the lever lock after confirming the clip came off from the bearing.

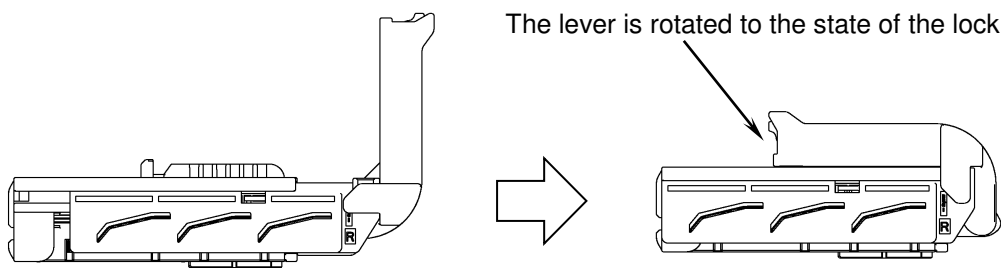

Fig.41

NOTE Please the clip recycling cannot not be done, and do not use the clip used once. There is a possibility of not functioning originally when using it again.

6.9 Lever removal job

(1)Release of lever

- ①The back of the lever is lightly pushed
- ②While the lever lock is pushed in cancellation direction
- ③Please turn the lever to pulling up direction

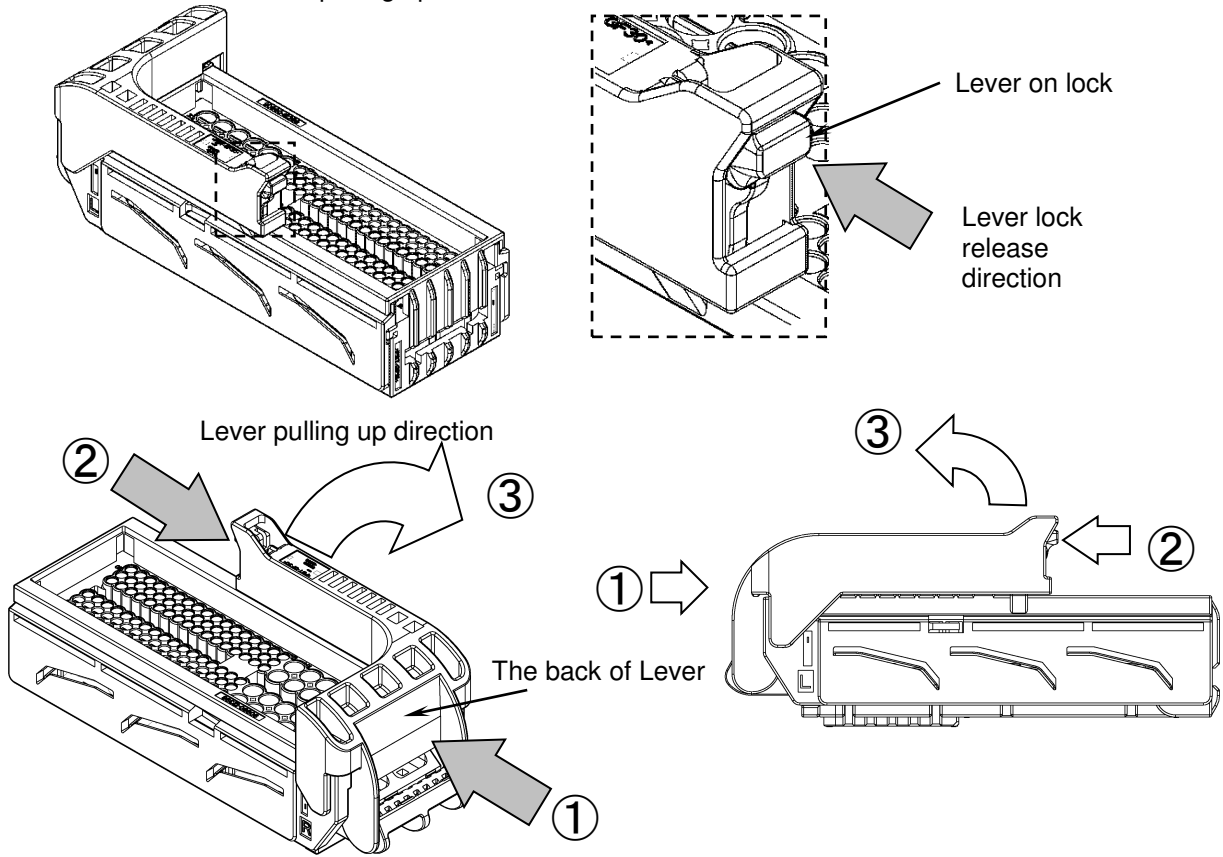

Fig.42

NOTE When the lever was pulled up when the lever lock is not cancelled, there is a possibility the lever lock making break.

(2) Release completion of lever

The lever it becomes completion of lever cancellation at the place where it becomes vertical mating the surface

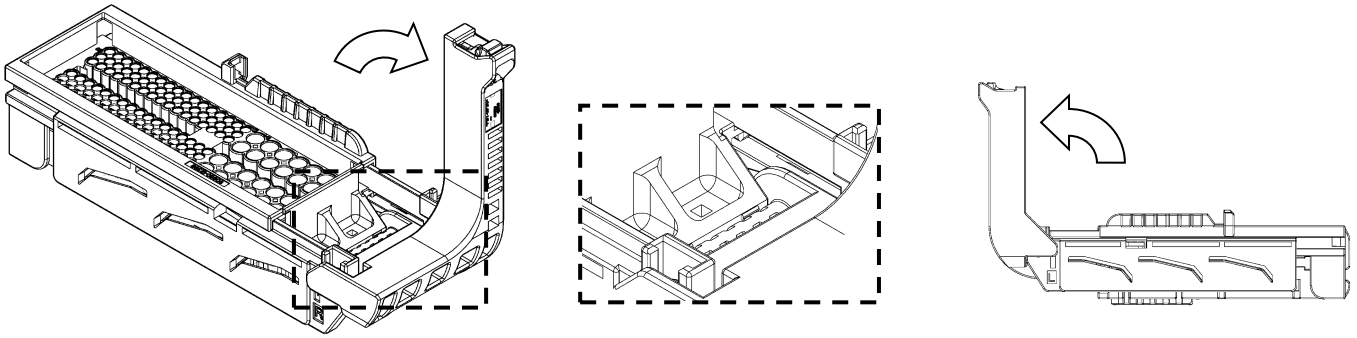

Fig.43

(3) Removal of lever

While turning the lever point to lever axial cancellation direction from cancellation state of the lever, until sound does the lever, please push.

Also please verify the lever frame comes off from the bearing of the lever.

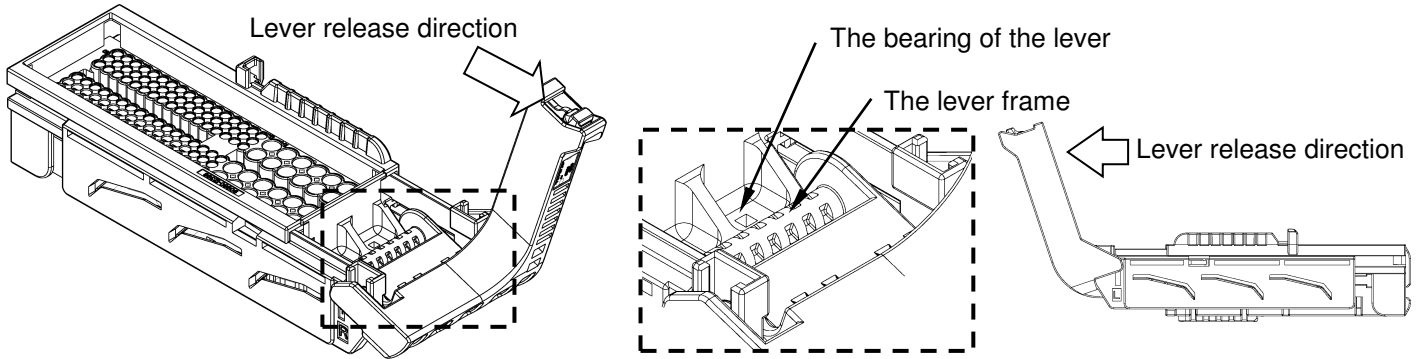

Fig.44

Please operate lightly in a direction opposite to cancellation direction after verifying that the lever frame comes off from the bearing of the plug housing, please remove the lever in lever removal direction.

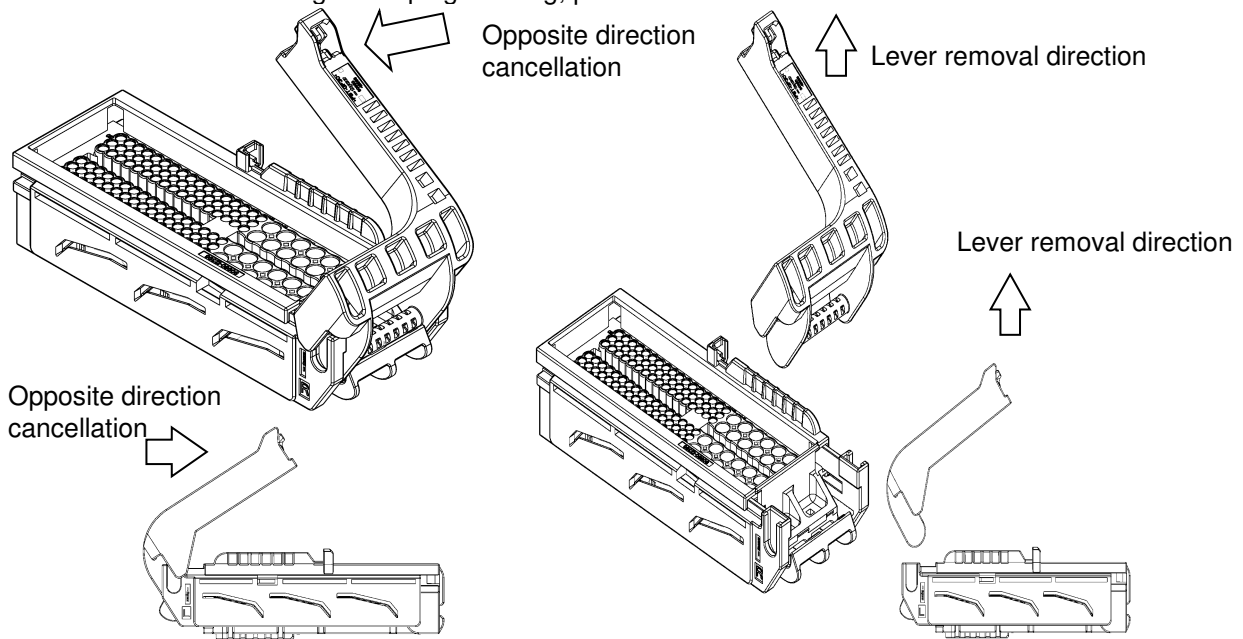

Fig.45

- NOTE** At the time of the lever removal when catching is felt, please verify the lever frame and that the bearing of the plug housing has come off.
- NOTE** Please reset the slider after the lever removing to initial position.
- NOTE** Please do not let the lever be locked, when you return the lever in a direction opposite to cancellation direction.

6.10 How to Extract Retainer

Confirm the retainer in pre-locked condition at extracting female terminals. If the retainer is in final-locked condition, the terminal can't be inserted or extracted. Draw out the retainer from final-locked condition to pre-locked condition as the following matters.

- (1) Insert 1mm precision screwdriver into hole on retainer.
- (2) Draw out the retainer about 1.4mm, Please verify that stuffing the person in charge stopping section is cancelled.

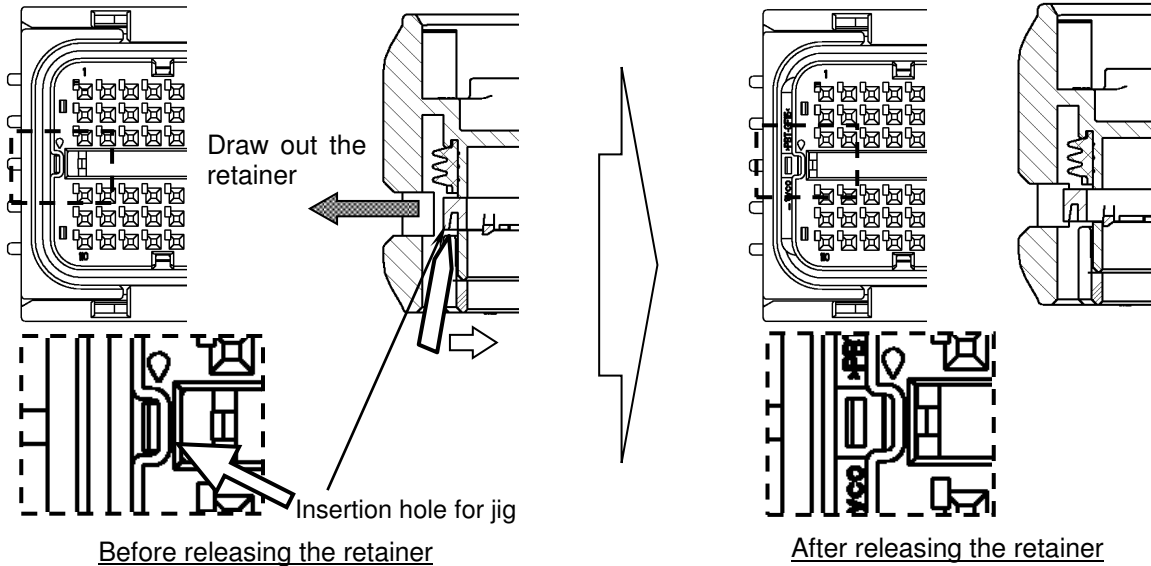

Fig.46

NOTE Please do not pull out the retainer above necessity. It becomes cause of damage.
NOTE Please do not insert the driver other than the jig insertion section.
 It becomes terminal deformation and cause of rubber damage for sealed.

6.11 How to extract the female terminal

- (1) Confirm the retainer in pre-locked condition.
 If the retainer is in final-locked condition, retainer must be changed in pre-locked condition; See para.6.10. The female terminal can not be extracted in final assembled condition.

•For 0.64 terminal

- ① Insert the special extraction tool into the proper hole.
- ② Remove the loaded terminal from housing with the crimped wire.

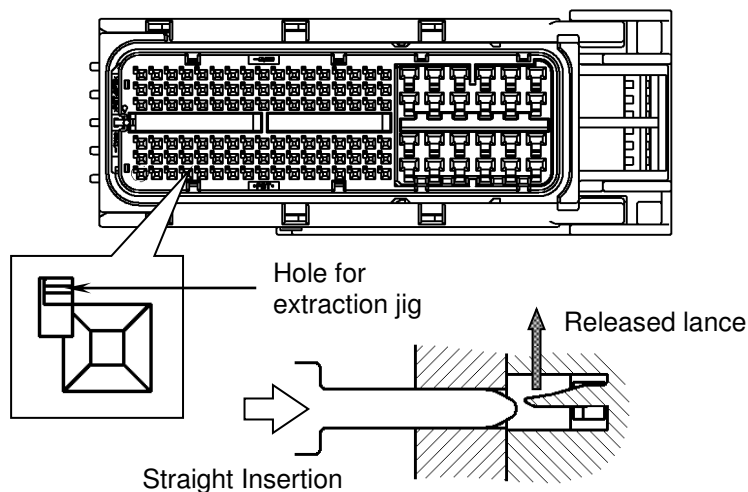

Fig.47

NOTE If terminal can't be drawn, pull out the special extraction tool, put back it again by wire and then insert the tool again. Become cause of deformed the tool or housing lance damaged forcedly. Don't repeat this operation more than 10 times, otherwise retention force has fallen. Don't use the tool for retainer extraction.

(3) For 2.3 II Terminal

- ① Insert the 1.2~1.6mm blade precision screwdriver into the proper hole.
- ② While referring to Fig.48, canceling the housing lance to pull the electric wire, please pull out the terminal.

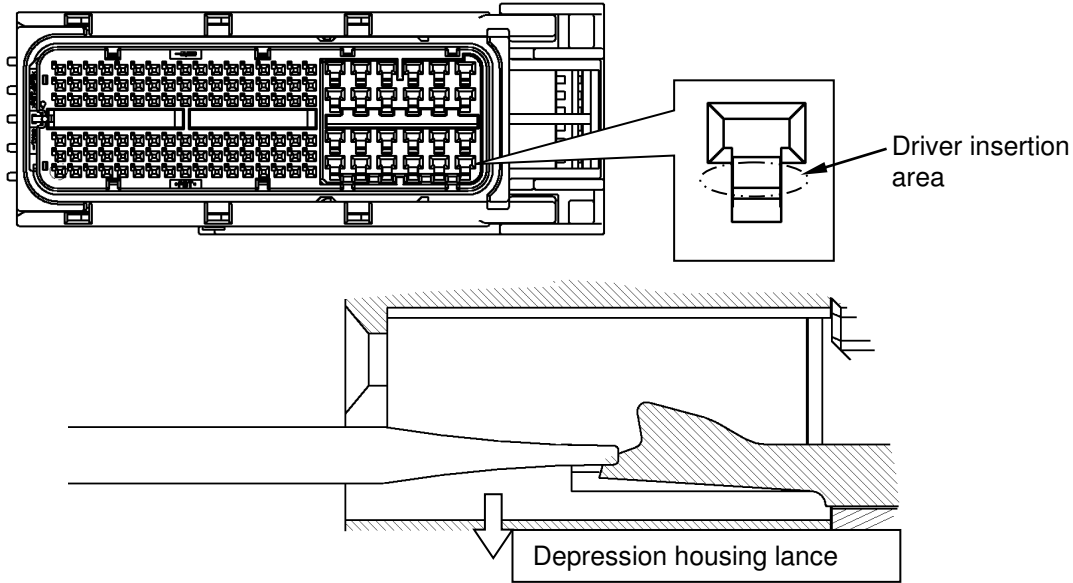

Fig.48

- (4) If the female terminal can't be extracted, don't pull the wire by force. Confirm the housing lance is unlocked.

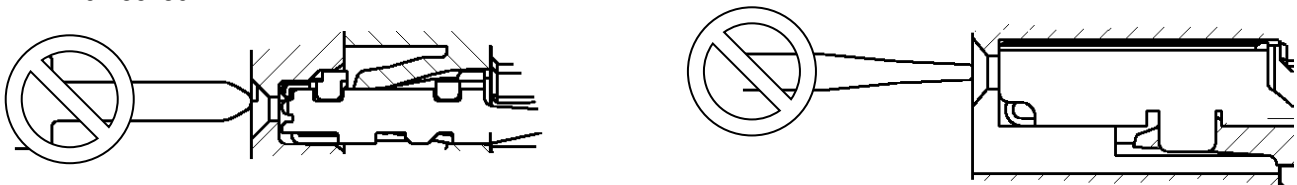

Fig.49

NOTE Do not insert the precision screwdriver or extraction jig into the female contact. If you insert this, the contact should be exchanged, not used.

6.12 Control of Harness

6.12.1 Control of Harness

Don't apply excess force or shock to the connector and wire.

6.12.2 Taping up wires

Tape up the wire at intervals of more than 30mm from the end of housing, not apply excess force to the wires.

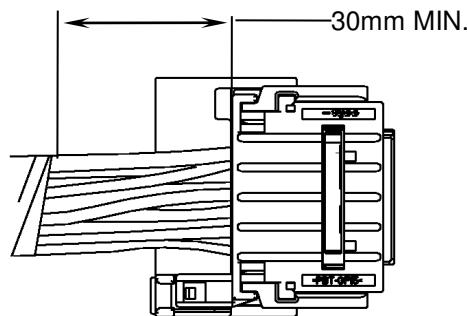

Fig.50

6.12.3 Harness Check

- (1) Applicable mating half or equivalent product should be used at harness checking.
- (2) Never insert probe pin into female terminal. The pin must be probed on wire side.

NOTE If the probe pin should be inserted, the female terminal must be renewed.

6.12.4 Storage

Avoid storing the connector in a moist or dusty place. Stock the connector away from direct sunlight.

6.12.5 Shipping and Carrying

The connector should be used with the proper packaging to prevent the ingress of dust, moisture, etc.

7. Lever cancellation job before the connector mating

- (1) ①The back of the lever is lightly pushed
- ②While the lever lock is pushed in cancellation direction
- ③Please turn the lever to pulling up direction

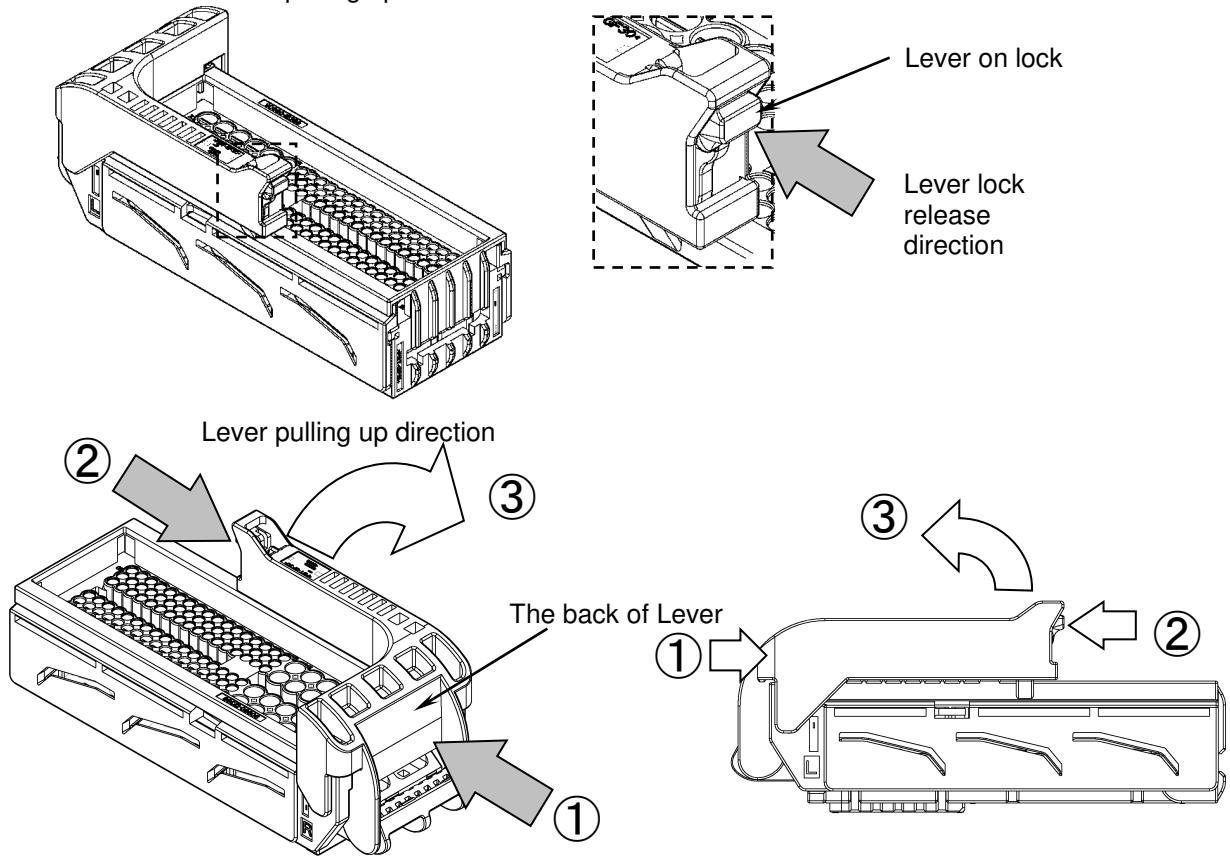

Fig.51

- (2) It becomes completion of lever cancellation at the place where it becomes vertical the lever the mating face.

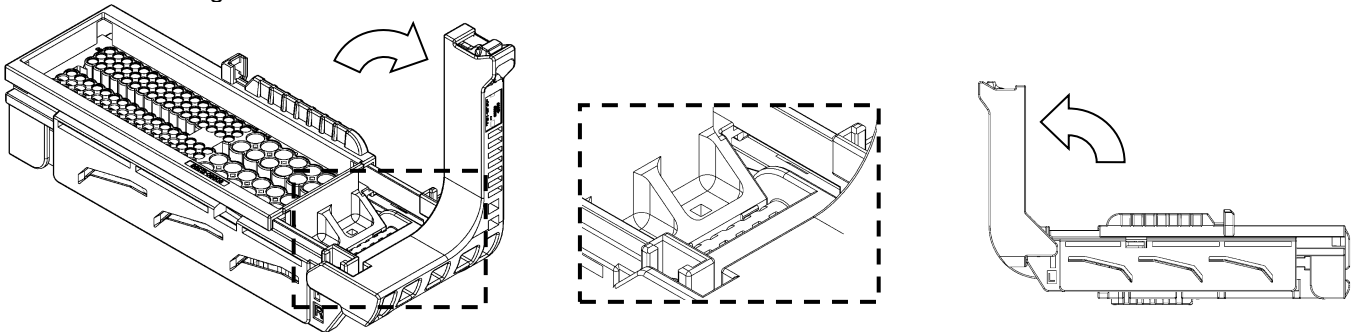
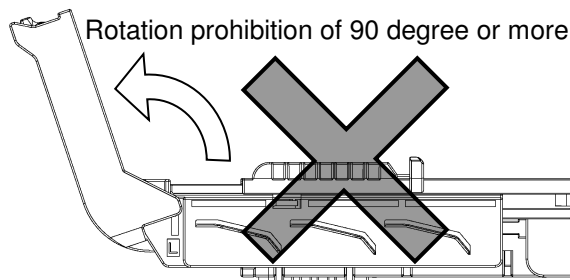

Fig.52

- NOTE** Please do not push the lever lock forcibly.
- NOTE** When abnormality is discovered, please be sure to exchange with the new item.
- NOTE** When the lever was pulled up when the lever lock is not cancelled, there is a possibility the lever lock making break.
- NOTE** Structure that the lever comes off when the lever is turned by 90 degree or more for connector damage prevention.



8. Mating and Extraction of Connector

8.1 Mating connector

- (1) Check the terminal fitting condition in housing, the position of taping up wire, and retainer final-locked condition. If the retainer is in pre-locked condition, press the retainer to final lock condition as Para.6
- (2) Check the defects, deformation, discoloration, damage, rust, crack, deficit, etc. of housing and contact.

NOTE Exchange the connector if any defects are found.

(3) Insert the proper female connector straightly into the male housing with the direction shown on Fig.53.

(4) Rotate the lever as arrow direction, If the operation is finished, you can hear the click sound and can't insert further. Don't apply excess force, if you can't insert into the male housing, and check the items of (1), (2).

NOTE Don't apply excess force without the insertion direction at inserting.

NOTE Don't nip the wires with lever at lever rotating.

NOTE After verifying the male connector boss and that the slider has fallen, please operate the lever in mating.

NOTE When at the time of lever operation abnormality is felt, without making fit unreasonably, after resetting one time lever, please do re-operation.

- ① push in into the direction of the arrow.

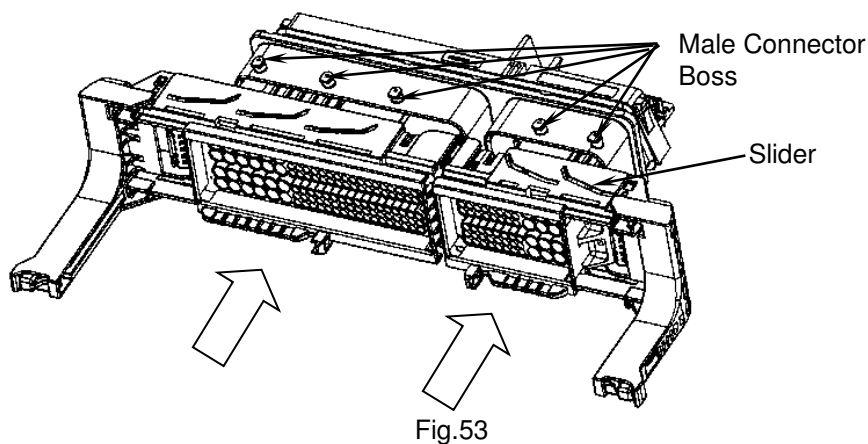

- ② Rotate the lever as shown

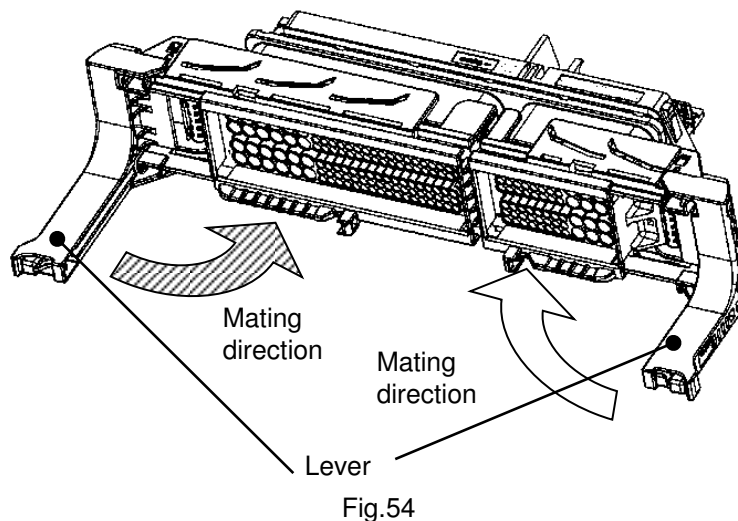

- ③ Finish

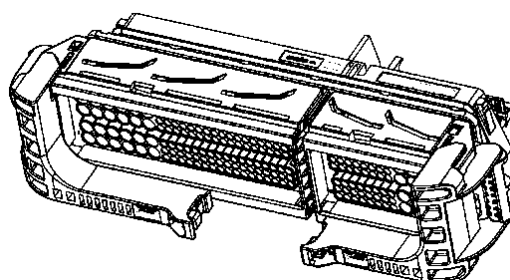

- (5) In addition, plug housing is lightly pulled, check that the connector doesn't come off.

8.2 Pulling out the connector

- (1) Please cancel the lever lock of the female connector. In order not to push the lever lock unreasonably, please note.
- (2) When it can cancel the lever lock, please turn to the point of you open the lever to direction of the arrow, becoming vertical mating the fit aspect.
- (3) The female housing, the wire cover and the wire - the clamp, please pull out straightly. When it cannot pull out, without pulling unreasonably, please verify that it becomes vertical the lever mating fit direction.

NOTE When pulling out, the slider, please do not grasp the lever.

NOTE When the wire cover is not with only the electric wire is grasped, please pull out the connector not to give the damage to the electric wire and the seal section.

①Lever lock cancellation

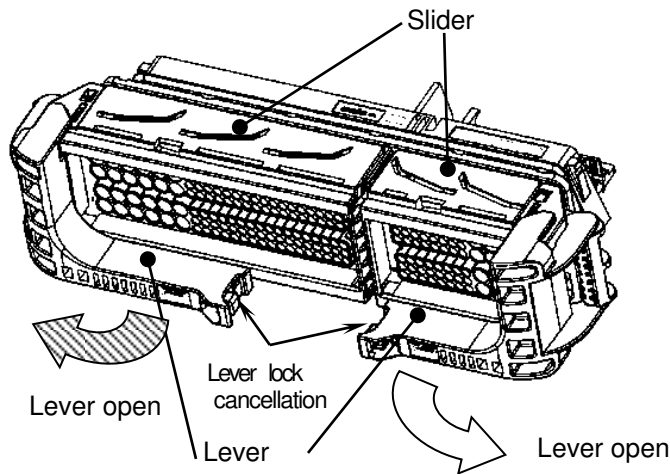

Fig.56

②Lever cancellation

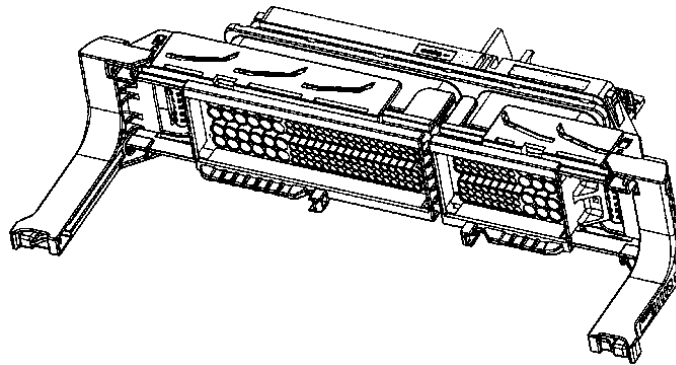

Fig.57

③Connector extraction

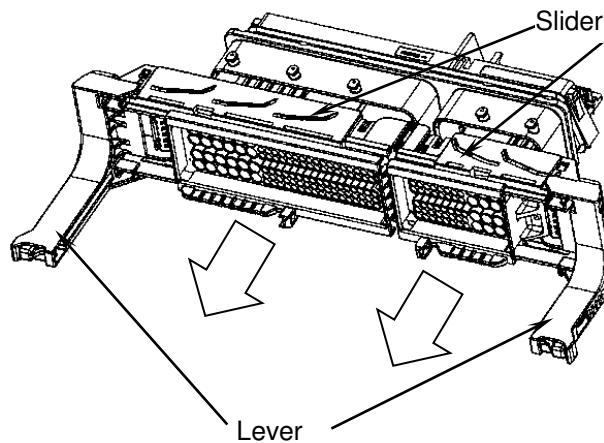

Fig.58

NOTE Don't apply excess force without the insertion direction at unmating

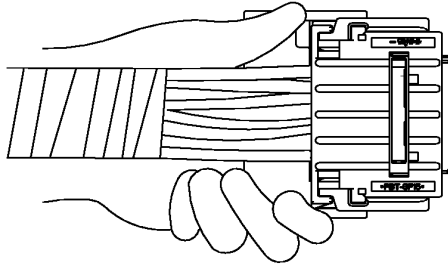

Fig.59

8.3 General Attention Matters

- (1) Don't mate and unmate the connector unnecessarily.
- (2) Don't insert any objects except the proper connector.
- (3) Don't apply unnecessary force or shock to the wire and connector at mating and unmating operation.

Point of caution when installing the SEALED EFI ECU CONNECTOR PLUG ASSY LEVER

Lever installation and removal job is recommend to execute in the environment of 10 degrees or more.
Please note that the resin might be damaged about work at 0 degree or less.

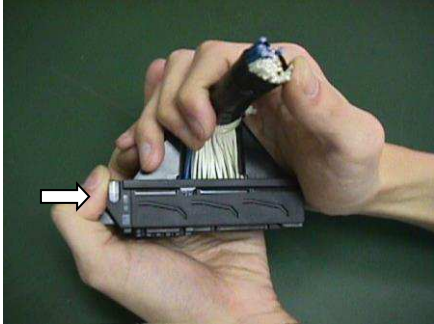

- (1) Resets two sliders until hitting to stopper.
There is a feeling when securely pushing until it hits the stopper because of idle.



- (2) The lever is placed in the support section and the lock section naturally.
Please verify that the lever of support section is placed parallel on the receiving side of the substance housing.



- (3) While receiving with the index finger of the both hands, you push it right under with the both hands thumb.
At this time, pushes naturally so that the pushed direction should not push outside.
Both hands of the thumb are preferable as like left photograph.



When removing the lever, note

Attachment data1 2/3

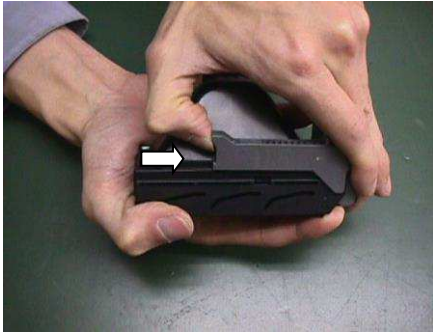

(4) Pushing the button of the lock, you remove the lock.
At the time, do not pull on unreasonably before coming off.



(5) The lever is pulled up gradually.



(6) There is one time moderation impression at position of 90 degrees and stops.



(7) Furthermore when it pushes down, power collects all at once until sound does, it falls in additionally and it stops. At this time, it does not keep pushing with force.



(8) To grip the lever lightly by the hand without connector, pull it forward, you remove from the support section.



(9) At this time, removes for the feeling lightly pulled without power. When movement such as caught is not smooth during work, does again without forcibly pulling.



(10) The lever comes off lightly.

Point of caution when installing the SEALED EFI ECU CONNECTOR PLUG ASSY CLIP

Lever installation and removal job is recommend to execute in the environment of 10 degrees or more.
Please note that the resin might be damaged about work at 0 degree or less.



(1) Please confirm doing to the installation of the lever by the harness manufacturing work.



(2) The clip is naturally put on the installation position of plug assembly.



(3) It pushes it the right under by the both hands thumb while receiving it by person finger of both hands. It pushes naturally so that there is no direction pushed at this time for outside. Both hands of the pushed thumb are as preferable as that of a left photograph.



When removing the Clip, note



(4) The lever is released according to the Instruction sheet.

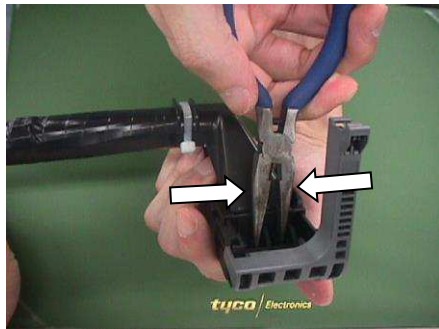

(5) The lock point of the clip is pushed internally With a tool etc. At this time, please note that the lock point is pushed so as not to damage the main body of the connector.

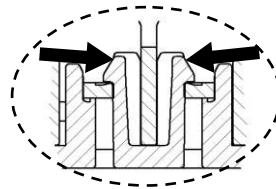

Lock section



(6) The clip comes off lightly. The clip cannot be used again when the connector is used again, and exchange it for the new item, please.



(7) After the clip removing, the lever is locked.