

1. Part Name and Part Number

This product line has been named as "11DIA SQUIB CONNECTOR SLIM TYPE MK-II" consisting of the part number as shown in Fig.1 and 2.

1.1 Housing:

*Part Number	Part Name
1612120	11DIA SQUIB CONNECTOR SLIM TYPE MK-II PLUG HOUSING
1612119	11DIA SQUIB CONNECTOR SLIM TYPE MK-II LOCKING BUTTON
353379	SQUIB CONNECTOR FERRITE

Fig.1

*Note : Part number is consisted from listed base number and 1 digit numeric prefix and suffix with dash. Refer to catalog or customer drawing for specific part numbers for each base number. When prefix zero, zero and dash are omitted.

1.2 Contact:

AMP Part Number	Part Name	Applicable Wire		
		Type	0.3	0.5
353376	SQUIB CONTACT	CAVS	○	○
		AVSS	○	○
		AVSSF	○	○

Fig.2

1.3 Product Composition:

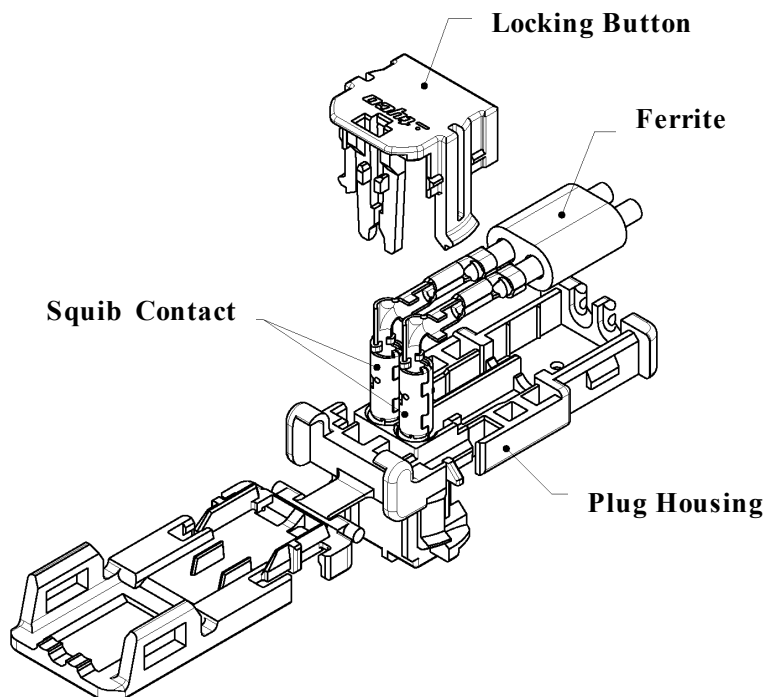
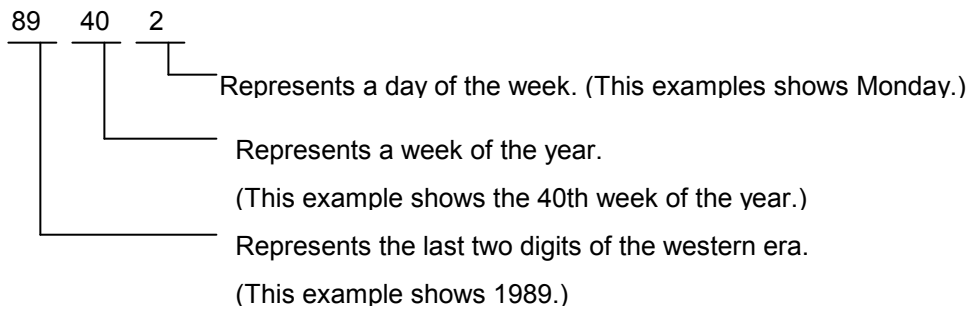

Fig.3

3.Inspection of Contact, Housing and Ferrite:

3.1 Preshipment Inspection by AMP

All the preshipment inspection by AMP are carried put for each shipment lot based on the quality control rules and applicable standards by means of the statistical control method. As a general rule, the manufacturing date is shown on each of the comparisons with the inspection records, manufacturing records, and adjustment records for the machines and measurement instruments. Note that the manufacturing date is shown using a date code specified below.



3.2 Customer 's Receiving Inspection:

Although, the products are thoroughly inspected before delivery, it is recommended that the customer be attentive to confirm the status of products, to check out if the products incurred any damage during transit.

<Contacts>

Item	Check Points	Measuring Apparatus
Visual Inspection	(1)Configuration and Appearance	Visual
	(2)Plating Finish	Visual
	(3)Reeling Status of Strip Terminals	Visual
Dimensional Inspection	(1)Width and Height of Wire Barrel	Calipers
	(2)Width and Height of Insulation Barrel	Calipers

Upon Receiving, the reeled terminal products should be classified by manufacturing date codes and put under the inspection in accordance with the inspection level II of MIL-STD –105 at acceptable quality level of 4.0%, visually and dimensionally to check the first five terminals in reel.

Acceptable of the products is verified by proving the products meeting the specified requirements.

<Housing>

Item	Check Points	Measuring Apparatus
Appearance Inspection	(1) Burrs, Discoloration & Deformation	Visual
	(2) Cracks, Breakage & Chipping off	Visual
Functional Inspection	(1) Mating Check to see if the connector mate and unmate smoothly with Gas Generator	Tactual

The product housings submitted to inspection, are classified by manufacturing date codes and put under the inspection in accordance with the inspection level II of MIL-STD -105 at acceptable quality level of 4.0%, visually and functionally to the randomly selected five pieced out of the lot.

Acceptable of the products is verified by proving the products meeting the specified requirements.

<Ferrite>

Item	Check Points	Measuring Apparatus
Appearance Inspection	(1) Burrs, Discoloration & Deformation	Visual
	(2) Cracks, Breakage & Chipping off	Visual

The product housings submitted to inspection, are classified by manufacturing date codes and put under the inspection in accordance with the inspection level II of MIL-STD -105 at acceptable quality level of 4.0% visually.

Acceptable of the products is verified by proving the products meeting the specified requirements.

4. Control of Crimped Products:

Crimping of contacts must be done by using AMP specified application tooling in accordance with the procedure specified in applicable instruction sheet.

After completion and of one crimping lot, it is desirable to record the part number, quantity and date code for the necessity of future reference.

4.1 Storage and Transfer of Reeled Products

- (1) Avoid leaving or carrying the contact reel in an open area without wrapping it in proper material.
- (2) Do not lift up and carry the contact reel by gripping one the side of reel, this may result in damage to the reel. and contacts before use. (See Fig.4)

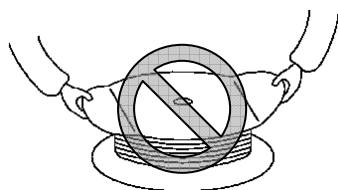

Do not lift up laterally holding one side only.

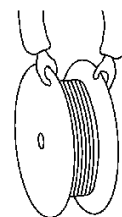

Acceptable

Fig.4

- (3) Avoid storing the contact reel in a moist or dusty place. Stock the reel in a comparatively dry and clean place (5~35°C, 45~85%RH) away from direct sunlight.
- (4) When removing the contact reel from the machine, fasten the end of contact strip onto the edge of the reel with use of proper string or wire. (See Fig.5)

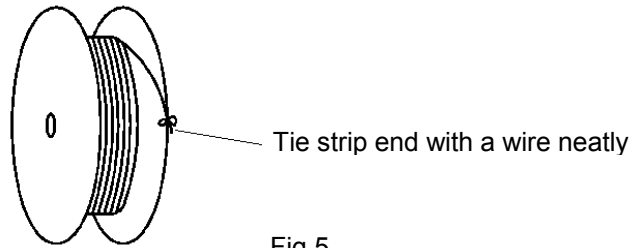

Fig.5

4.2 Reference Documents for Crimping Operation

The documents listed below should be referred to for the specific details of crimping and assembly operation.

114-5234:Application Specification for Socket Contact for 1mmDIA Pin.

- (1) Wire end must be stripped without nick, cutoff, or damage of wire strands.

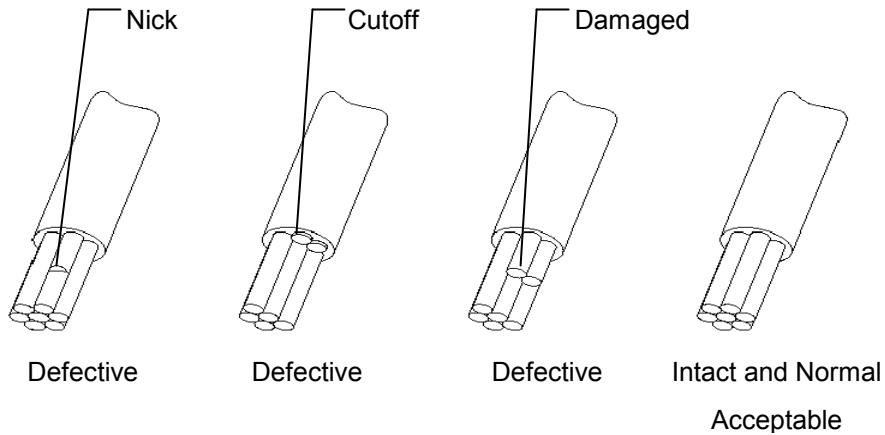
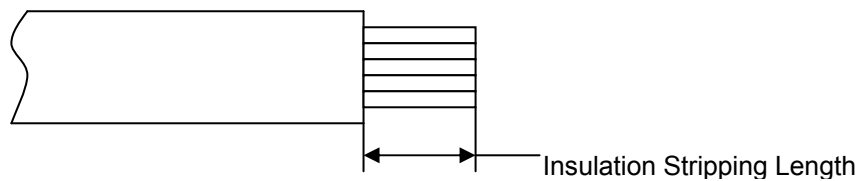

Fig.6

- (2) Wire end Pre-treatment before Crimping:



Length of Wire Barrel to be Crimped + (0.5~1.0mm)

Fig.7

(3) Cross-section View of Wire Barrel Crimp:

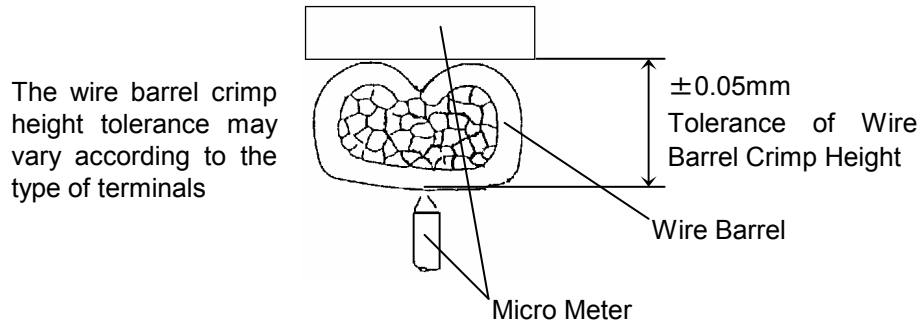

Fig. 8

(4) Modified Micrometer for Measurement of Crimp Height:

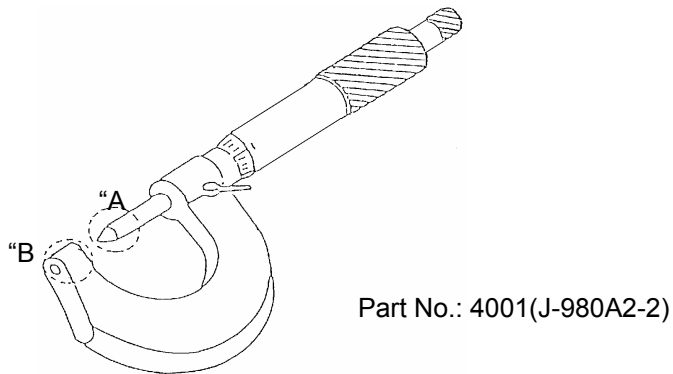

Fig.9

4.2.1 Crimped Condition of Contact:

(For detailed features, refer to Application Specification, 114-5234:Socket Contact for 1mmDIA Pin)

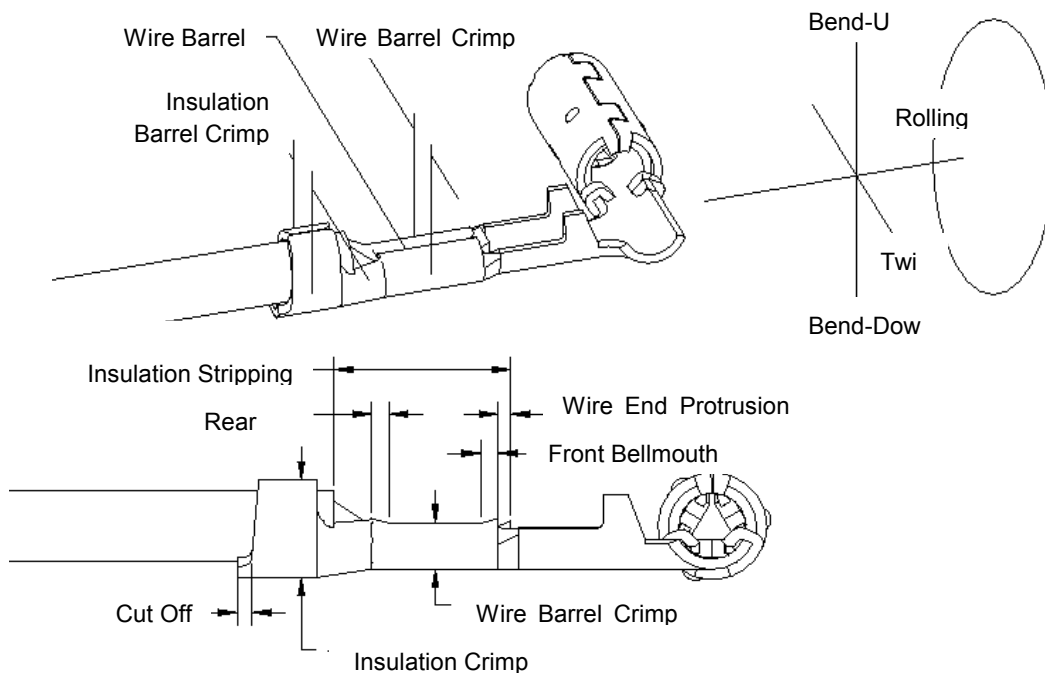

Fig.10

4.2.2 Crimp Data:

The following shows the detailed data of contact crimping by applicator. Confirm the contents before the operation.

Contact Part Number	Wire Size (Nominal)	Applicator Number	Wire Barrel Crimp (mm)			Insulation Barrel Crimp (mm)			Crimp Tensile Strength (N) (Min)
			Width	Height	Disc	Width	Height	Disc	
353376	0.3	409644-2	1.78	0.94	C	1.78	2.29	3	59
	0.5		"F"	1.03	B	"F"	2.37	3	88

4.2.3 Applicable Wires:

Applicable Wires to be Automotive Low Voltage Wires. (AVSS, CAVS 0.3~0.5mm²)

Wire Size (Nominal)	No. of Conductors/ Diameter of a Conductor	Cross-Sectional Area of a Conductor	AVSS/CAVS	
			Std.	Max.
0.3	7/0.26	0.37	1.4	1.5
0.5	7/0.32	0.56	1.6	1.7

4.3 Control of Crimped In-process Products:

4.3.1 Inspection of Products

Inspection of crimped. In-process products must be performed by the lot unit consisting of the product group manufactured during the one continuous operation under the same set-up adjustment of the crimping machine in the identical manufacturing conditions, or the groups of the produced products during one work day operation.

The inspection should be performed according to the criteria shown in the listing below.

Inspection Types	Timing	Inspection Items
Inspection on Products made under initial set-up condition of applicator	At the time of completion of initial set-up of applicator to crimp the contact.	Visual inspection and Dimensional Inspection on all items listed in Fig.
Lot Inspection	Before to start a routine operation each work day	Same as above
	During continuous operation	Visual inspection on all the items listed in Fig.17, and Dimensional Inspection on item No.3 only in Fig. .

Inspection Types	Checking Points and methods	Measuring Apparatus
Visual Inspection	1.Loose-out of the wire conductors out side the wire barrel crimp, and cut-off of conductor	Visual
	2.Defective crimped form of contact (forming up of bell mouth, and wire end protrusion length)	Visual
	3.Defective wire barrel bottom area forming (burr appearing, inclusive)	Visual
	4.Misgripping of insulation barrel crimp on wire insulation	Visual
	5.Defromation of contacting area of contact	Visual
Dimensional Inspection	1.Dimensions of Cut-off Tab Length:0.5mm Max.	Calipers
	2.Deformation of contact (bend-up, lateral bend and twisting)	Magnifying Glass
	3.Crimp Height	Micrometer
	4.Front and rear bellmouth forming Front bellmouth:0.2mm Max. Rear bellmouth:0.5mm Max.	Calipers

NOTE Calipers are defined as vernier calipers or equivalent measuring tools, having the identical precision measurement level.

4.3.2 Storage and Handling

- (a) Store the products in the clean, dry area, and should be covered with proper sheet or paper when placed in an open area. Product storage without placing cover sheet when placed in an open air, should be forbidden always for prevention of contamination by dust and particles.
- (b) One bundle of in-process crimped leads, should be confined within 100 leads at anytime.
- (c) Avoid stacking and piling up the in-process products heaping up in large volume, lest it should result in catching together or entangled on the projecting parts of the leads, causing damage and breakage of the products. Deformation of the contact will result in malfunction of contacting parts electrically.
- (d) When to separate parts apart, care must be taken not to jerk and pull forcefully with cross section area. (Fig.11)

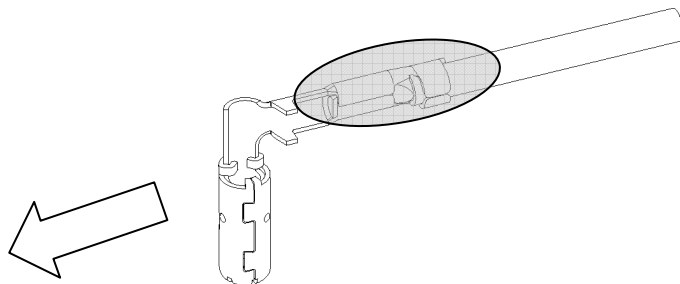

Fig.11

5. Manufacturing Harness Assembles:

5.1 Loading Wire into Ferrite:

Before strip insulation, thread ferrite on a wire and crimp contacts.

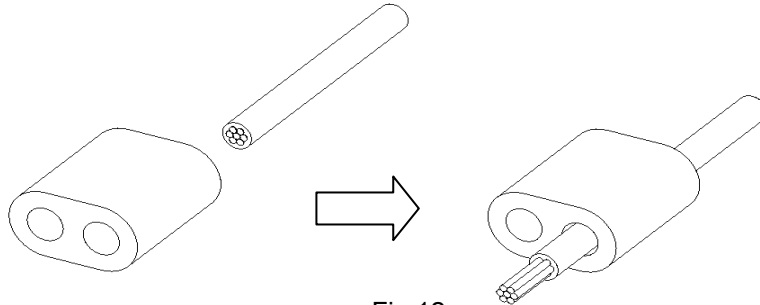

Fig.12

5.2 Loading Contacts into Main Housing

Insert the contact into the designated hole of the housing, until it goes to the bottom and to get engaged with the locking device, when a small clicking sound is heard at engagement of locking. Do not push part of crimping, but section area on Fig.13.

Before loading contacts into housing, insert the ferrite into the designated position. When the contact is locked, just pull back the crimped wire lightly, to make sure the condition of locking, as the contact stray in place of locking.

If not to insert contacts and ferrite into designated position, the lid housing will be allowed to lock in position.

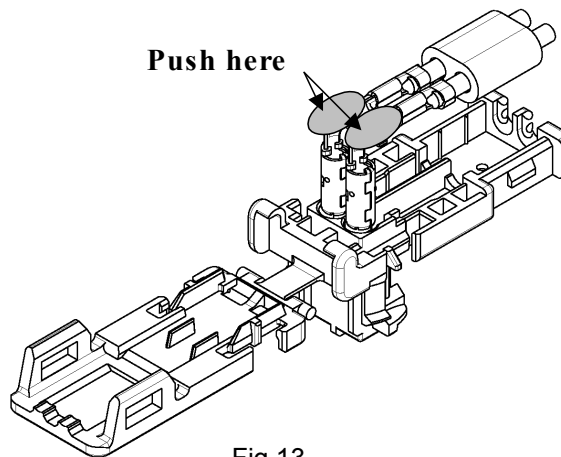

Fig.13

5.3 Loading Lid into Main Housing

(1) Press Cylinder "B" of Lid on Aperture "A" of Main

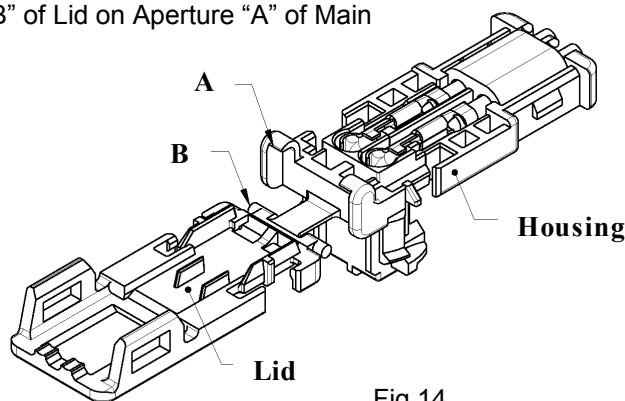

Fig.14

(2) Be sure to revolve Lid

Lift the lid up and then fold the lid down onto the base of the connection.

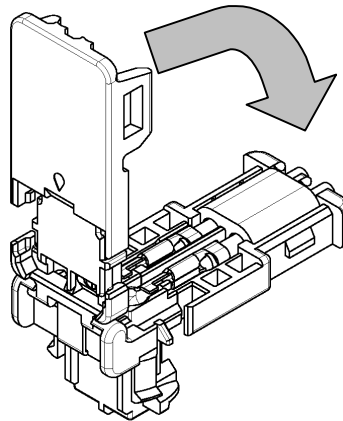

Fig.15

(3) It is finish when Lid is locked

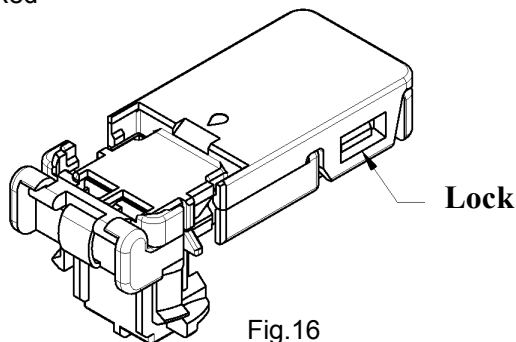

Fig.16

NOTE

To make sure the cylinder, get into aperture. If the cylinder not get into aperture, try again.

If you will control final assemble to use of dimension, to make sure as below.

If hinge break during revolve Lid, must cut remnant part by nipper.

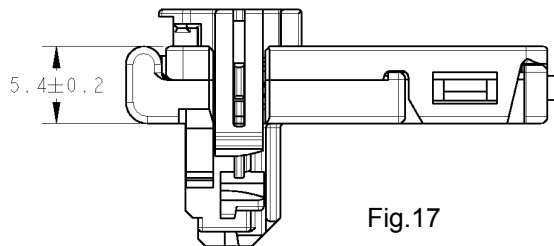

Fig.17

5.4 Assemble locking button into a connector housing

(1) Insert stick of Locking Button into a connector housing hole.

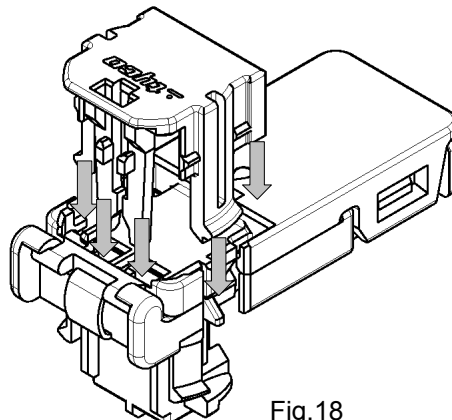

Fig.18

(2) Push the locking button to pre-assembly position.

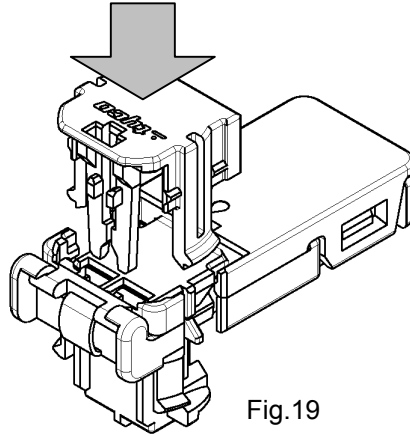

Fig.19

(3) Check if the locking button is placed on the position like Fig. .

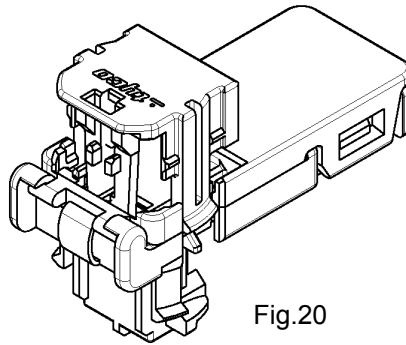

Fig.20

NOTE

Do not push the button over pre-assembly position by force.

If you do, housing and locking button will break.

If you will control final assemble to use of dimension, to make sure as below.

Push the center of locking button straight .

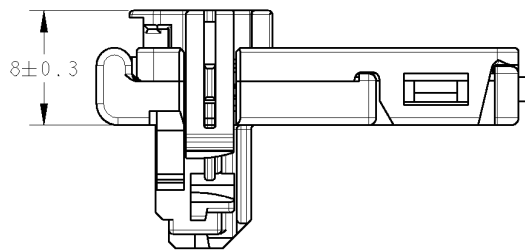

Fig.21

5.5 Storage of Housing and Ferrite:

5.5.1 Housing

(a) It is desired that the products are placed where the temperature is ranging between 5~35degree with the relative humidity ranging between 45~85%.

(b) It is advised that leaving the products in open air for a long time tends to get contaminated by dust and particles.

Leaving under the open air for a long time should be forbidden from this point of view.

5.5.2 Ferrite

- (a) It is desired that the products are placed where the temperature is ranging between 5~35degree with the relative humidity ranging between 45~85%.
- (b) Do not hit fellow ferrite.
- (c) Do not drop ferrite.

6. How to Extract Female Contact

When extract contact from housing, put a screwdriver (1.0mm) to the place of Fig.22, and pull back it.

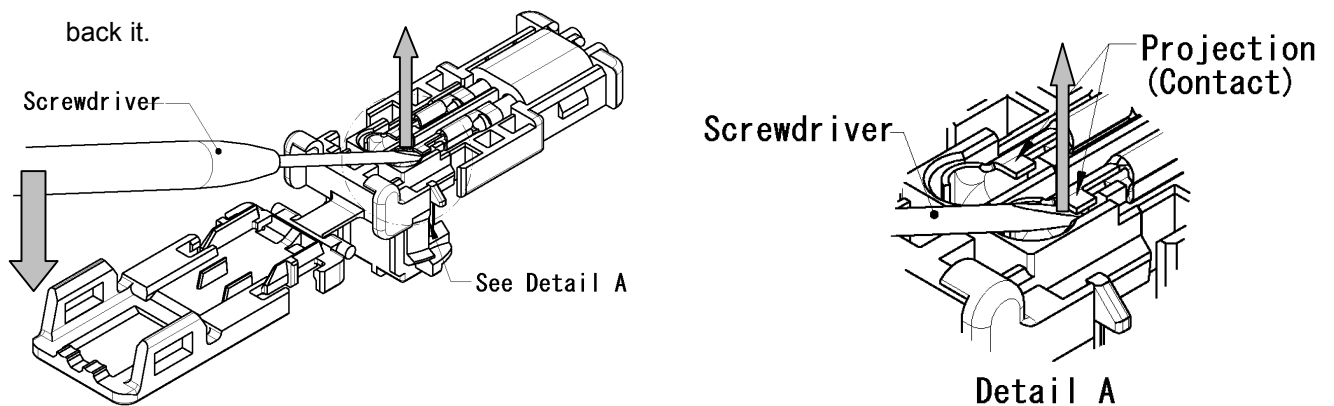

Fig.22

NOTE

- (a) Do not pull the wire.
- (b) During removal operation of contact, care must be taken not to cause deformation of contact, housing, ferrite. If you find deformations, do not attempt to reuse them.
- (c) When you assemble them again, see Para. 5.2~5.4.
- (d) Confirm to insert ferrite into designated position.

7. Inspection, Storage and Transit of the Products:

7.1 Inspection of Products

During the inspection of the product harnesses, the following practice should be observed rightly.

- (a) Use the counter part contact tab or equivalent part for checking circuit continuity of the harnesses, as a probing contact.
- (b) Never insert inspection probe inside the contacts.

In any time, inserting probe of the circuit tester will invite danger of deforming of contacts in housing, especially doing it by contact side. If the use of probing is required, insert it from the Wire side of housing.

7.2 Storage of Products

For storage of the products, place them in clean, dry place without fear of contamination. It is advised that leaving the products in open air for a long time tends to get contaminated by dust and particles. Leaving under the open air for a long time should be forbidden from this point of view.

7.3 Delivery Transit and Carrying

- (a) Use proper carton box or container for delivery transit and carrying, to protect the product harnesses from contamination by dust and rain water etc. Try to handle moderately without shock, weighty load and impact.
- (b) For the correct and normal control, the product part number, quantity and product code etc. must be clearly marked on the container legibly.

8. Mate with Instrument

8.1 Receiving Inspection

For final receiving inspection, the following items are required for confirmation of assembly normality.

- (a) The banding positions of leading wires bundle out of the connector should be not less than 20mm when the bundle is not bent, and 10mm when the bundle is bent.
- (b) Condition checking of contact loading on housing.
- (c) Checking on condition of contact surfaces for presence of remarkable discoloration, flaws and deformation of the contact.
- (d) Check for presence of cracks, defects and discoloration of housing.
- (e) Check for any abnormalities existing in the contained products and delivery dates.

8.2 Mating Operation

(1) Mating of connector

- (a) Check the direction, the position of housing's rib and instrument's ditch.
- (b) Mate the connector straight with pushing the center of button.

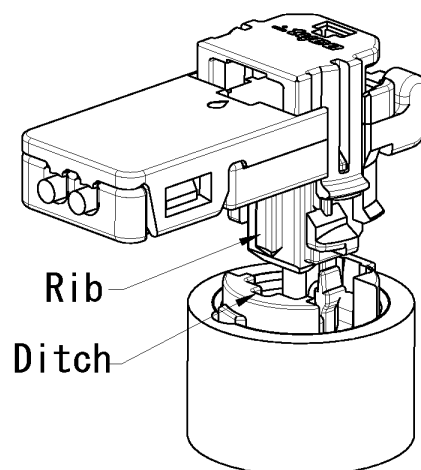

Fig.23

NOTE

Do not mate the connector by force, when the rib of housing don't meet the ditch of instrument.

(2) Pushing the locking button

(a) Push the center of button straight.

(b) Push it until the top of locking button and housing is on a level.

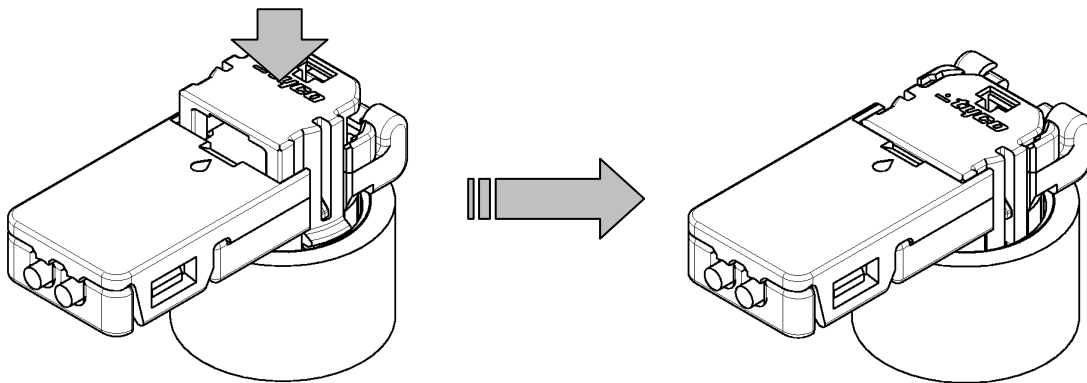

Fig.24

NOTE If you push the center of locking button on (1)(2), mating of connector will complete surely.

9. Unmating of connector

(1) Remove the locking button

Pull up with screwdriver. (see Fig.25)

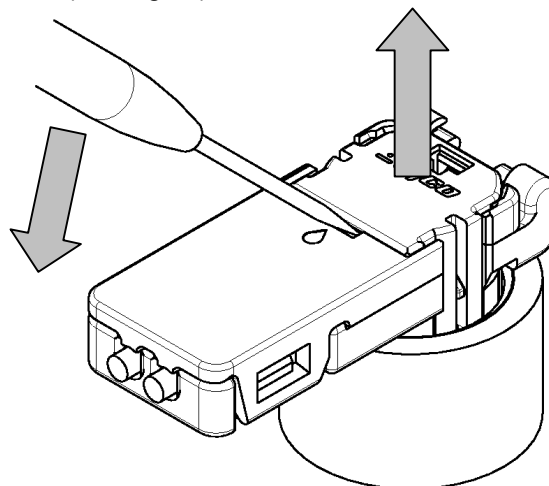

Fig.25

NOTE

(a) Do not pull up over the pre-assemble position.

(b) If the locking button is off, check the button and housing, and refer to 5.4.

- (2) Pull up the connector

Pull up straight with handling housing.

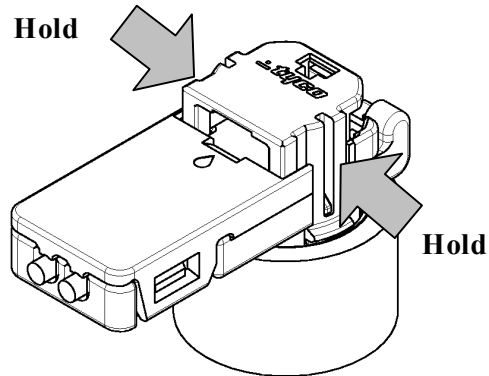

Fig.26

NOTE

- (a) Do not pull up with the locking button.
- (b) Do not pull up with the wire.
- (c) When mate the connector again, check the position of locking button is pre-assemble and then obey 8.2.
- (d) When you pull out the contact, obey the following.

If any parts break, you should change them.

- (1) Pull up the locking button.

It is kept to housing by 5 locks (see Fig.27).

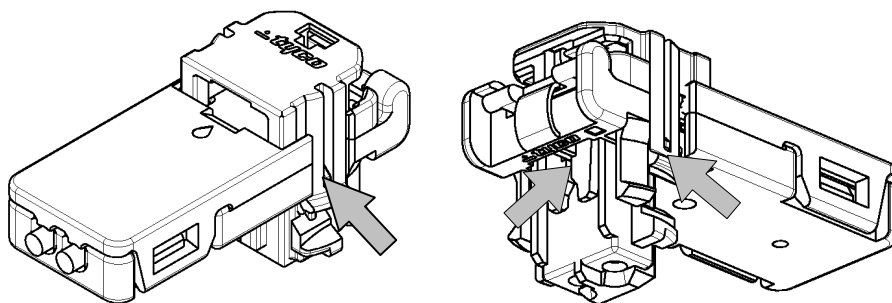

Fig.27

- (2) Remove 2 locks between housing and lid.

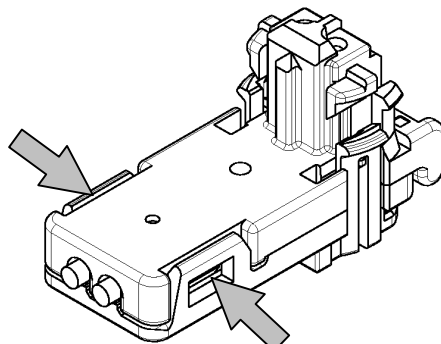

Fig.28

(3) Revolve the lid around "A".

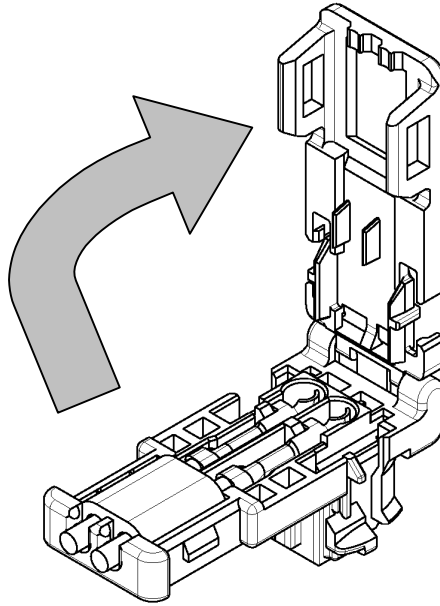

Fig.29

(4) Pull out the contact.

See Para.6.

10. Taping on the Wire Bundles:

When to apply taping over the wire bundles, the following care should be taken:

The crimped wire leads running out of housing must be properly bundled and taped accordingly to the length apart from wire run-out of connector so as to bundle up or bend due to harness assembly layout, lest it should affect forcing stress to the wires and then to the loaded contacts, causing defective mating of connectors and the defective circuit connection.