

CONNECTOR				CABLE			
PART NUMBER AND CATALOG NUMBER (mm [In.])	LENGTH (mm [In.])	OD (mm [In.])	SOCKET SIZE (mm [In.])	CONDUCTOR RANGE	STRIP LENGTH (mm [In.])	CONDUCTOR DIAMETER RANGE (mm [In.])	REMOVE INSERT FOR CONDUCTOR SIZE GREATER THAN (mm [In.])
1574846-4 ASBS-2-3/0 (2-Bolt)	65 [2.5]	24 [.95]	10 [3/8]	2 AWG Compact Stranded to 3/0AWG Standard Stranded	28.5 [1 1/8]	6.8 - 11.9 [.268 - .470]	1/0 AWG Compact Stranded 8.5 [.336] Diameter
1099739-1 ASBS-2-350 4-Bolt)	100 [3.9]	31 [1.22]	13 [1/2]	2 AWG Compact Stranded to 350 kcmil Standard Stranded	44.4 [1 3/4]	6.8 - 17.3 [.268 - .681]	4/0 AWG Standard Stranded 13.4 [.528] Diameter
1701211-1 ASBS-3/0-500 (4-Bolt)	125 [4.9]	34 [1.3]	13 [1/2]	3/0 AWG Compact Stranded to 500 kcmil Standard Stranded	60 [2 3/8]	10.7 - 20.6 [.423 - .813]	300 kcmil Standard Stranded 16 [.630] Diameter
1099735-1 ASBS-500-750 6-Bolt)	152 [6]	39 [1.52]	13 [1/2]	500 kcmil Compact Stranded to 750 kcmil Standard Stranded	69.8 [2 3/4]	18.7 - 25.3 [.736 - .998]	600 kcmil Compact Stranded 20.6 [.813] Diameter
1099383-1 ASBS-350-750 6-Bolt)	170 [6.7]	42.5 [1.67]	13 [1/2]	350 kcmil Compact Stranded to 750 kcmil Standard Stranded	80 [3 1/8]	15.6 - 25.3 [.616 - .998]	600 kcmil Compact Stranded 20.6 [.813] Diameter
1099848-1 ASBS-600-1000 (6-Bolt)	203 [8]	44.4 [1.75]	13 [1/2]	600 kcmil Compact Stranded to 1000 kcmil Standard Stranded	95 [3 3/4]	20.6 - 29.2 [.813 - 1.152]	750 kcmil Standard Stranded 25.3 [.998] Diameter

Figure 1

1. INTRODUCTION

This instruction sheet provides installation procedures for Aluminum ShearBolt connectors.

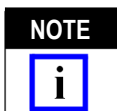

Dimensions in these instructions are in metric units [with imperial units in brackets]. Figures are for reference only and are not drawn to scale.

Reasons for reissue of this instruction sheet are provided in Section 3, REVISION SUMMARY.

To obtain information on Energy Products, visit the TE Connectivity Energy website at: <http://energy.te.com>.

ShearBolt Connectors are designed to be compatible with all Raychem cable accessories and insulation products. For other applications, consult the manufacturer's installation instructions for compatibility.

2. INSTALLATION PROCEDURES

2.1. Cable Preparation



CAUTION DO NOT use a conductor that has been previously terminated.

1. Determine the conductor sizes to be installed. Ensure that each conductor end has a straight (right-angle) cut. Strip both conductor ends to the dimension shown in Figure 1.
2. Using a wire brush dedicated for use on aluminum or copper conductors, thoroughly clean the bare surface strands of each conductor end. Cleaned conductor ends should be installed immediately to prevent reformation of fresh oxides.

2.2. Connector Installation

1. Determine whether the insert should be removed according to conductor size (see Figure 1). If insert removal is required, use a small screwdriver to lift or tap the insert from the connector body. If insert is not removed, ensure it is properly positioned in the connector barrel during installation (insert indent seated in connector notch). DO NOT remove the inhibitor contained inside the connector.
2. Back out all bolts to give clearance for the conductor in the connector body.



CAUTION Do not completely remove the bolts from the connector body. Removing bolts followed by improper bolt re-installation could result in stripping of the threads.

3. Insert the conductors into the connector body. For proper installation, there should be NO GAP between the insulation and the connector body.



NOTE To facilitate assembly when two different conductor sizes are to be installed, it is recommended to insert the larger conductor into the connector barrel first.

4. Tighten bolts in a three-step process:

- a. Hand-tighten the bolts to firmly grip conductors in place. Follow the tightening sequence shown in Figure 2.
- b. Using a wrench with a hexagonal socket, tighten the bolts one to one-and-a-half turns, (one second interval if using the TE Connectivity [cordless] impact wrench), repeating the sequence in the previous step. Bolts should remain un-sheared. Prevent core bending by using Holding Tool IT-1000-019 (or equivalent) with the wrench as shown in Figure 2.

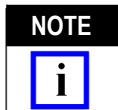

NOTE Cordless Impact Wrench T25446-000 can be used instead for installation. A holding tool is not needed if using this wrench.

- c. Repeat the sequence (above), tightening each bolt until the head of the bolt shears off. The wrench should remain parallel to the connector body.

5. Smooth sharp edges of protruding bolts using the provided aluminum oxide paper or a file. Clean connector to remove particles.

3. REVISION SUMMARY

Revisions to this instruction sheet include:

- Changed dimensions in Figure 1.
- Add note in section 2.2 for insert positioning.
- Change to DeWalt Impact Wrench.
- ShearBolt Head A/F Dimension Change

Bolt Tightening Sequence

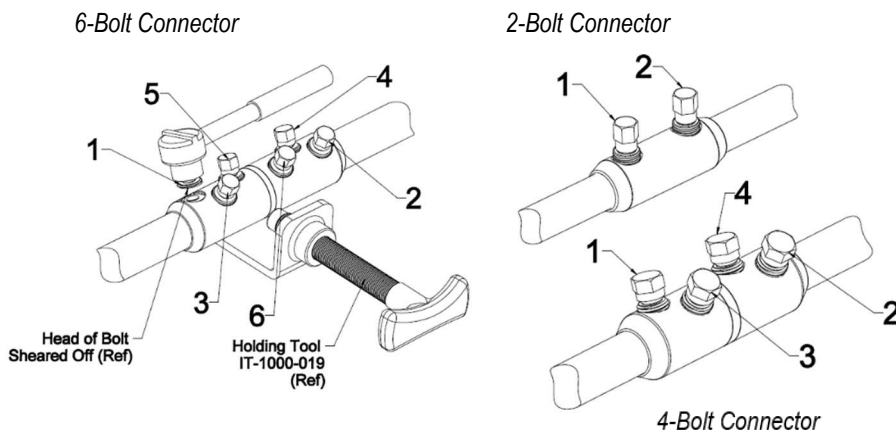

Figure 2

Impact Wrench



Cordless Impact Wrench (T25446-000 Ref)