

Figure 1

1. INTRODUCTION

This instruction sheet contains the assembly procedures for QMA Bulkhead Cable Jack Connector 1408349-1. See Figure 1. This solder attachment type jack is used on .141 semi-rigid (RG402/U) and conformable cables with similar diameters.

The table in Figure 2 represents tool numbers applicable to this instruction sheet.

TOOL DESCRIPTION	TE CONNECTIVITY PART NO.
Center Contact Holder	1055454-1
Solder Gage	91362-6

Figure 2

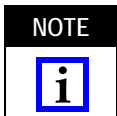

Dimensions on this instruction sheet are in millimeters [with inches in brackets]. Figures and illustrations are for reference only and are not drawn to scale.

2. DESCRIPTION

QMA Bulkhead Cable Jack Connector consists of a housing subassembly and a center contact.

3. ASSEMBLY PROCEDURES

3.1. Preparing Coaxial Cable End (Figure 3)

1. Remove the end portion of the outer conductor and dielectric to expose the inner conductor.
2. Trim the inner conductor to length.

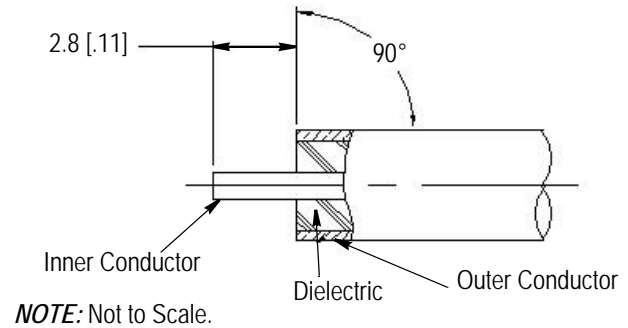

NOTE: Not to Scale.

Figure 3

3.2. Soldering Center Contact to Inner Conductor (Figure 4)

1. Tin inner conductor of cable.
2. Place contact in center contact holder.
3. Heat contact and push it over the inner conductor to rest firmly against the solder gage, as shown in Figure 4.
4. Remove excess solder.

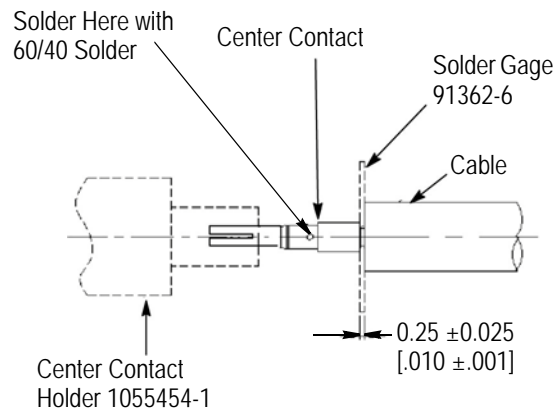

Figure 4

3.3. Soldering the Cable to the Housing Subassembly (Figure 5)

1. Insert cable subassembly into housing subassembly and seat firmly.
2. Hold cable firmly seated and solder the housing subassembly to the outer conductor.

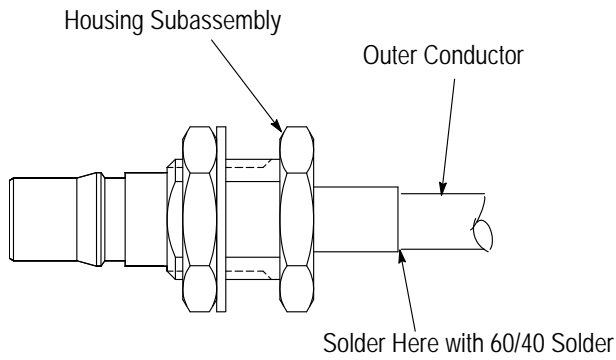

Figure 5

3.4. Inspection of Completed Assembly

Following the assembly procedures in this instruction sheet should yield tolerance shown in Figure 6.



Damaged components should not be used. They should be replaced with new components.

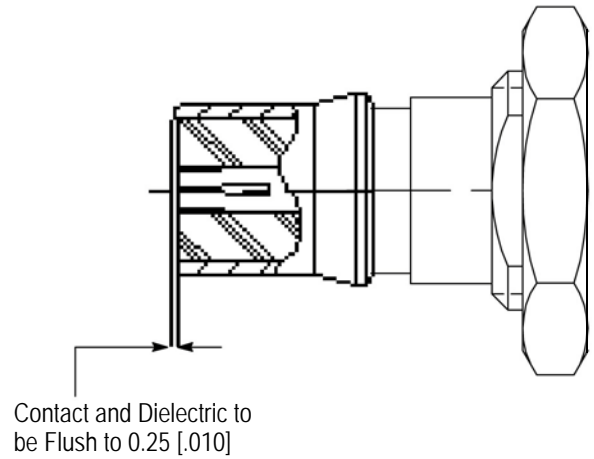

Figure 6

4. REVISION SUMMARY

- New logo