

Figure 1

1. INTRODUCTION

This instruction sheet contains the assembly procedures for QMA Straight Cable Plug Connector 1408346-1. See Figure 1. This solder attachment type plug is used on .141 semi-rigid (RG402/U) and conformable cables with similar diameters.

The table in Figure 2 represents tool numbers applicable to this instruction sheet.

TOOL DESCRIPTION	TYCO ELECTRONICS PART NUMBER
Center Contact Holder	1055454-1
Solder Gage	91362-6
Locator Tool	1673603-1

Figure 2

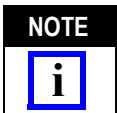

Unless otherwise stated, dimensions on this instruction sheet are in millimeters [with inches in brackets]. Figures are not drawn to scale.

2. DESCRIPTION

QMA Straight Cable Plug Connector consists of a housing subassembly and a center contact.

3. ASSEMBLY PROCEDURES

3.1. Preparing Coaxial Cable End (Figure 3)

1. Remove the end portion of the outer conductor and dielectric to expose the inner conductor.
2. Trim the inner conductor to length.

3.2. Soldering Center Contact to Inner Conductor (Figure 4)

1. Tin inner conductor of cable.
2. Place contact in center contact holder.

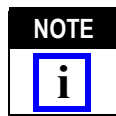
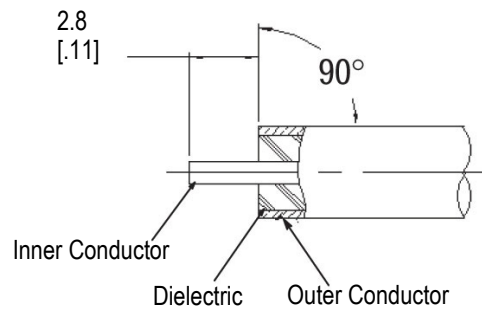

Not to Scale

Figure 3

3. Heat contact and push it over the inner conductor to rest firmly against the solder gage, as shown in Figure 4.

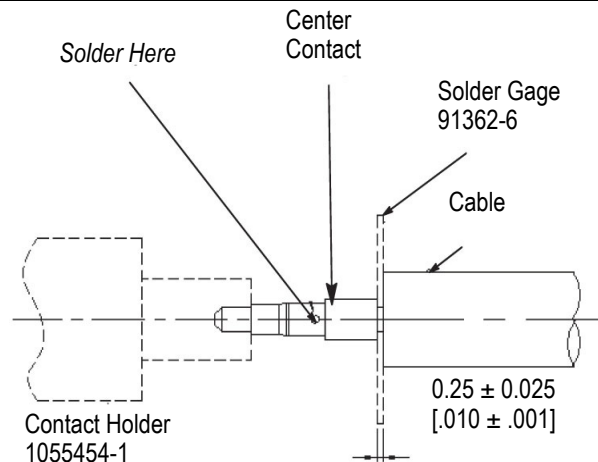

Figure 4

4. Remove excess solder.

3.3. Soldering the Cable to the Housing Subassembly
(Figure 5)

1. Insert locator tool into housing subassembly.
2. Insert cable subassembly into housing subassembly and seat firmly.
3. Hold cable firmly seated and solder the housing subassembly to the outer conductor.
4. Remove locator tool.

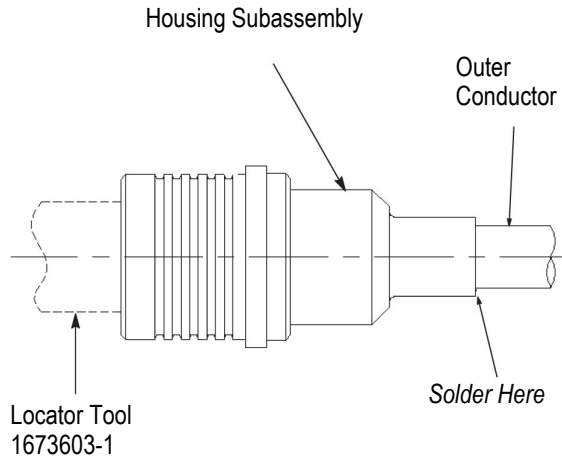

Figure 5

3.4. Inspection of Completed Assembly

Following the assembly procedures in this instruction sheet should yield tolerance shown in Figure 6.



Damaged components should not be used. They should be replaced with new components.

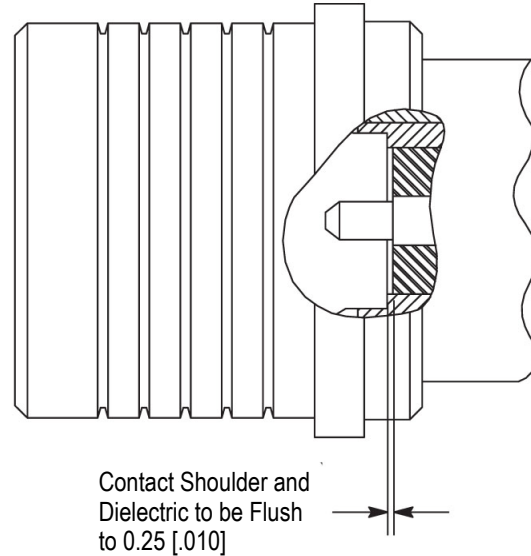

Figure 6

4. REVISION SUMMARY

Since the previous release of this document, the TE logo was applied.