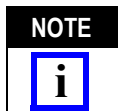

Figure 1

1. INTRODUCTION

The SFP connector and cage assembly are used to interconnect SFP fiber optic or copper transceiver modules to printed circuit (pc) boards.

The cage assembly consists of a top cage and bottom cage. The dust cover is used to prevent contaminants from entering the chassis before the module (or transceiver) is installed.



Dimensions in this instruction sheet are in millimeters. Figures are not drawn to scale.

2. DESCRIPTION

The connector contains right angle surface mount contacts and features a card entry slot that accepts the 1.0+0.1 thick integrated circuit card housed in the module.

The top cage and bottom cage have interlocking tabs and locking windows for positive locking after

assembly. The top cage features EMI suppression pins, and panel ground springs to provide electrical contact to the bezel. The bottom cage features a locking latch for holding the mating module in place and a kick-out spring to release the module for removal. The cage assembly is designed to be bezel mounted.

3. ASSEMBLY PROCEDURE

1. Install the connector and bottom cage onto the pc board according to Application Specification 114-13017. Refer to Figure 2.
2. Position the top cage over the bottom cage, aligning the locking windows and interlocking tabs with the bottom cage locking windows and interlocking tabs. Make sure that top cage EMI suppression pins align with the matching holes in the pc board. See Figure 3, Detail A.

Connector and Bottom Cage Installed onto PC Board

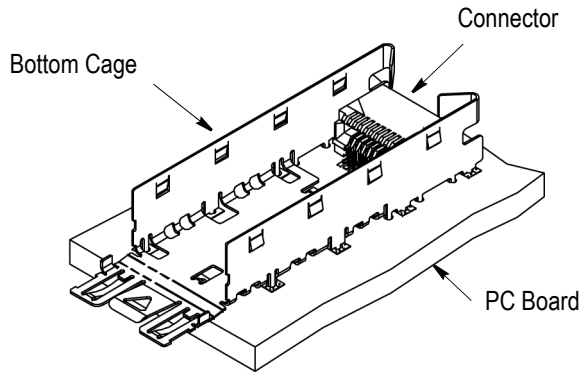
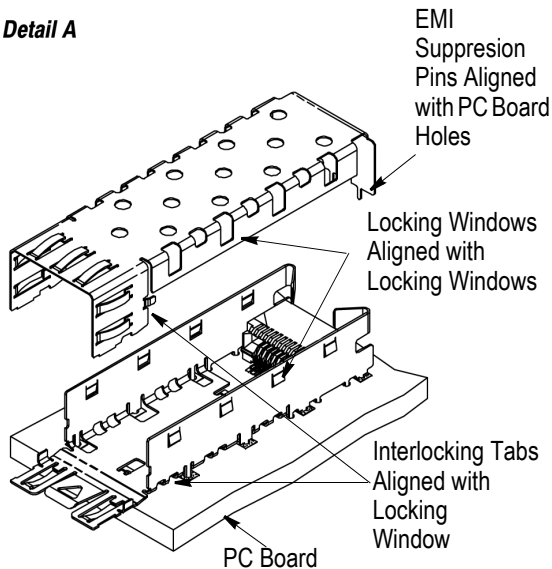

Figure 2

Detail A



Detail B

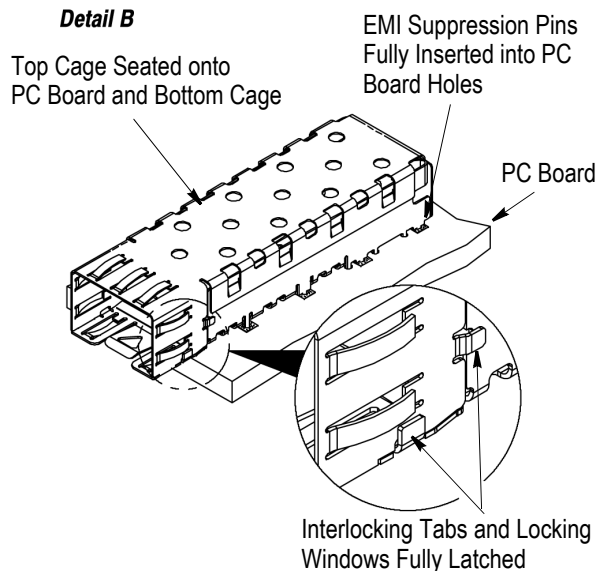

Figure 3

3. Simultaneously seat the top cage onto the bottom cage and pc board. Make sure that the top cage EMI suppression pins are fully inserted into the appropriate holes in the pc board, and the top cage locking windows and interlocking tabs are fully seated and latched onto the bottom cage. See Figure 3, Detail B.

4. Design the bezel according to 114-13017.

5. Install the cage assembly onto the bezel. Make sure that the top cage and bottom cage panel ground springs touch the bezel and the bottom cage module locking latch is slightly raised. A slight bow in the cage assembly is permitted. The bezel must not interfere with the function of the bottom cage module locking latch. See Figure 4.



CAUTION To avoid interference with the function of the bottom cage module locking latch and to ensure proper function of the panel ground springs, IT IS IMPORTANT that the bezel and pc board be positioned in relation to each other as shown in Figure 4.

6. If the module isn't being installed, assemble the dust cover over the opening of the cage assembly.

Cage Assembly Installed onto Bezel (Side View)

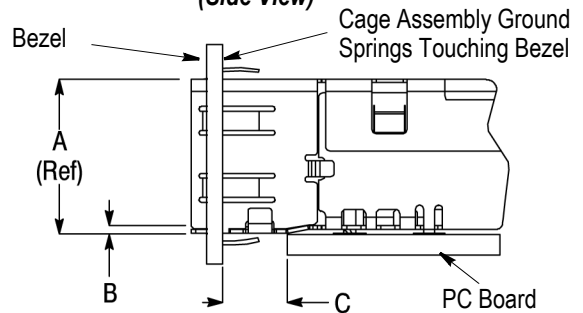

DIMENSION

A	B	C
10 (Top of Cage Assembly to Top of PC Board)	0.4±0.1 (Bottom of Cutout in Bezel to Top of PC Board)	2.9±0.9 (Distance Between Back of Bezel and Front of PC Board)

Figure 4

4. REVISION SUMMARY

Since the previous release of this instruction sheet, the TE Connectivity logo has been applied.