

AMP

AMP INCORPORATED
Harrisburg, Pa. 17105

AMP ★ BOX CONNECTOR JACKSCREW ASSEMBLIES

Instruction Sheet

IS 6624

RELEASED

6-1-84

REDUCED FOR PACKAGING

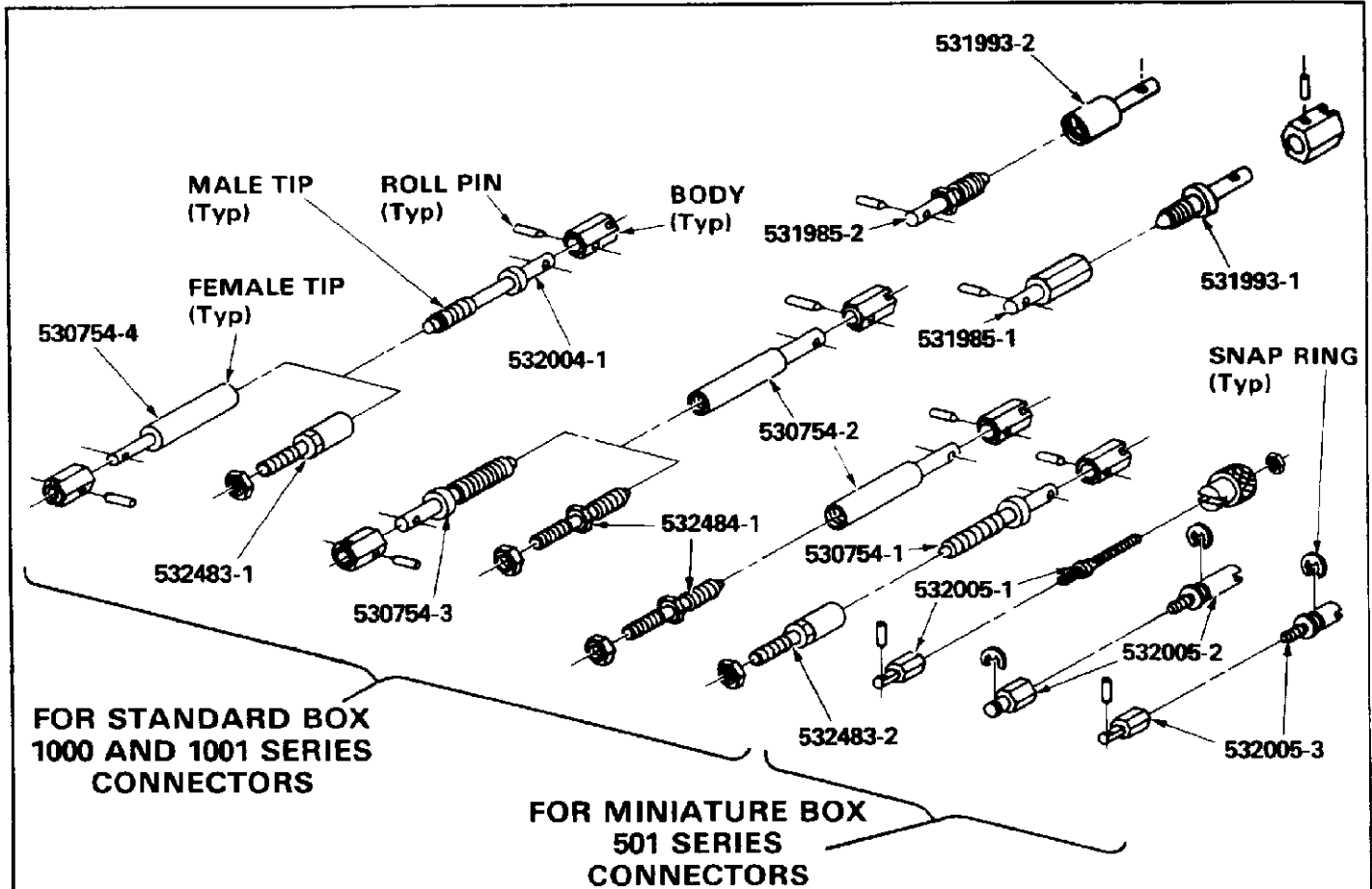

Copyright 1982, 1984 by AMP Incorporated, Harrisburg, Pa. All International Rights Reserved. AMP Incorporated products covered by U.S. and Foreign patents and/or patents pending.

KIT NO.	TYPE	STYLE	JACKSCREW KITS		CONNECTOR DESIGNED FOR	
			NO.	TYPE		
530754-1	Turnable	Male	532483-2	Fixed	531840 and 531841	
-2		Female	530754-3	Turnable		
-3		Male	532484-1	Fixed		
-4		Female	532484-1	Fixed		
532483-1	Fixed	Female	530754-2	Turnable		
532484-1		Male	532004-1			
531985-1	Turnable	Female	530754-2			530942, 531721, 531722, and 531802
531985-2		Male	531993-1			
532004-1			531993-2			
532005-1	Fixed	Female	530754-4			530753, 530752, and 530755
-2		Male	532483-1	Fixed		
-2		Female				
-3		Male				
-3		Female				

*THESE KITS CONSIST OF A MATING MALE AND FEMALE JACKSCREW TIP WITH ASSOCIATED HARDWARE.

Fig. 1

1. INTRODUCTION

This instruction sheet (IS) covers the selection and assembly of AMP Box Connector Jackscrew

Assemblies. See Figure 1.

Read this material thoroughly before starting to assemble parts.

2. DESCRIPTION

The jackscrews are designed for positive and quick mating and unmating of connectors. They can be used for free-hanging or mounted connectors for cable-to-cable, cable-to-panel, or board-to-board applications.

Two types of jackscrews (fixed and turnable) and two styles (male and female) are available. See Figure 1.

The fixed jackscrew kits consist of a tip and a hex nut or roll pin. They are rigidly attached to the connector. We recommend that they be attached on the most stationary connector (panel and pc board mounted connectors) and on connectors with the shortest leads. Generally, these are energized receptacle connectors. See Figure 1.

The turnable jackscrew kits consist of a tip with a body and a roll pin or a snap ring. They rotate freely after attachment. We recommend that they be attached to the free-hanging connector with the longest leads. See Figure 1.

NOTE

Also available are combination jackscrew kits consisting of turnable male tips and fixed female tips. These kits are designed for AMP Miniature Box Connectors (Figure 6).

3. ASSEMBLY PROCEDURE

The jackscrew kit to be selected depends on the application, which may be a cable-to-cable, cable-to-pc board, or board-to-board application. These applications, jackscrew selection, and assembly procedures are as follows.

Different style (male/female) jackscrews can be used for polarization. The following illustrations show two different styles (male and female) in each connector; however, two of the same style can be used in a connector.

NOTE

Opposite style jackscrews **MUST** be used in mating connectors (male jackscrews to female jackscrews).

NOTE

Roll pins are installed using a pair of pliers or other suitable tool.

A. Cable-to-Cable Connector Application – 1000/1001 Series

1. Free-hanging Connectors (Figure 2)

1. Select two jackscrew kits 532004-1 or 530754-2 (or 1 each) for the pin contact connector.
2. Select two jackscrew kits 530754-4 or 530754-3 (or 1 each) for the receptacle contact connector.
3. Assemble each kit by inserting the tip into the front of the connector, sliding the body onto the tip shaft, aligning the roll pin holes, and installing the roll pin.

2. Free-hanging and Panel Mounted Connector (Figure 3)

1. Select two jackscrew kits 532004-1 or 530754-2 (or 1 each) for the free-hanging pin contact connector.

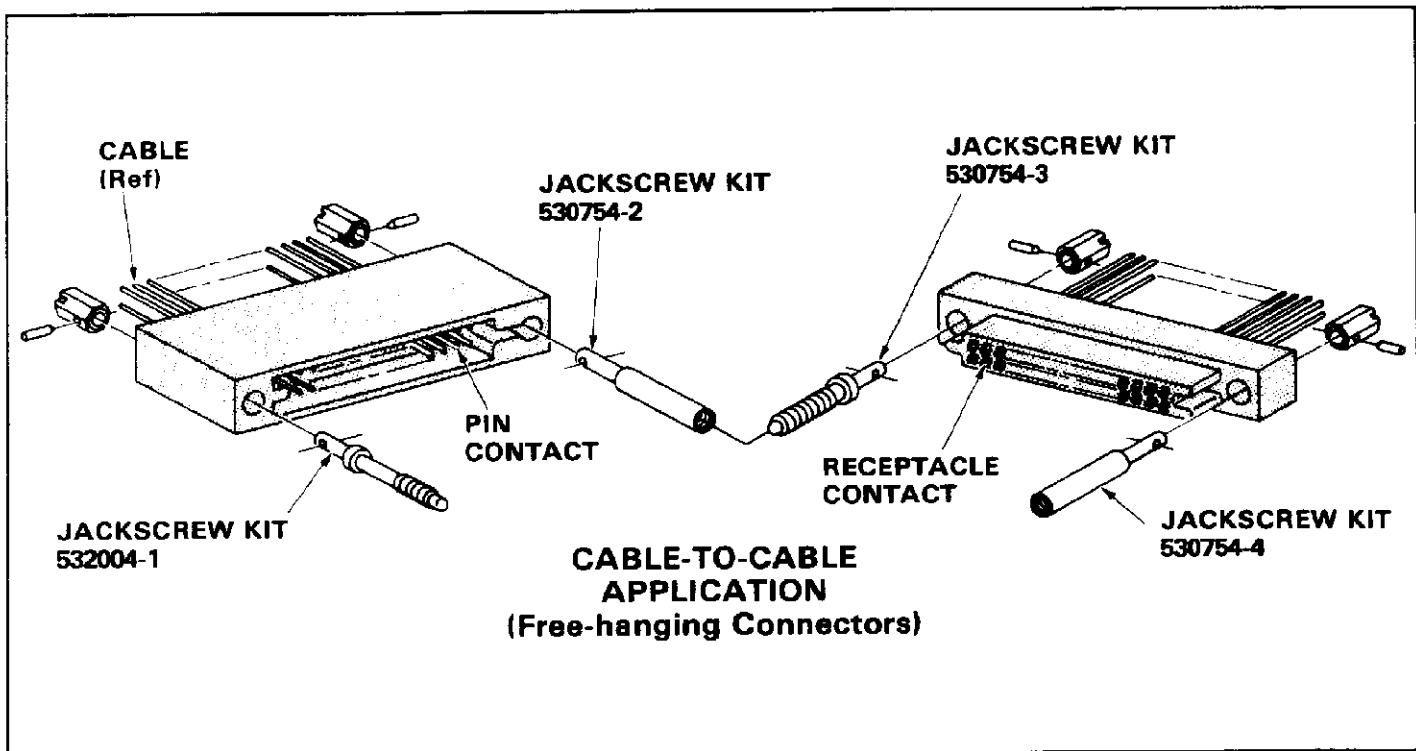

Fig. 2

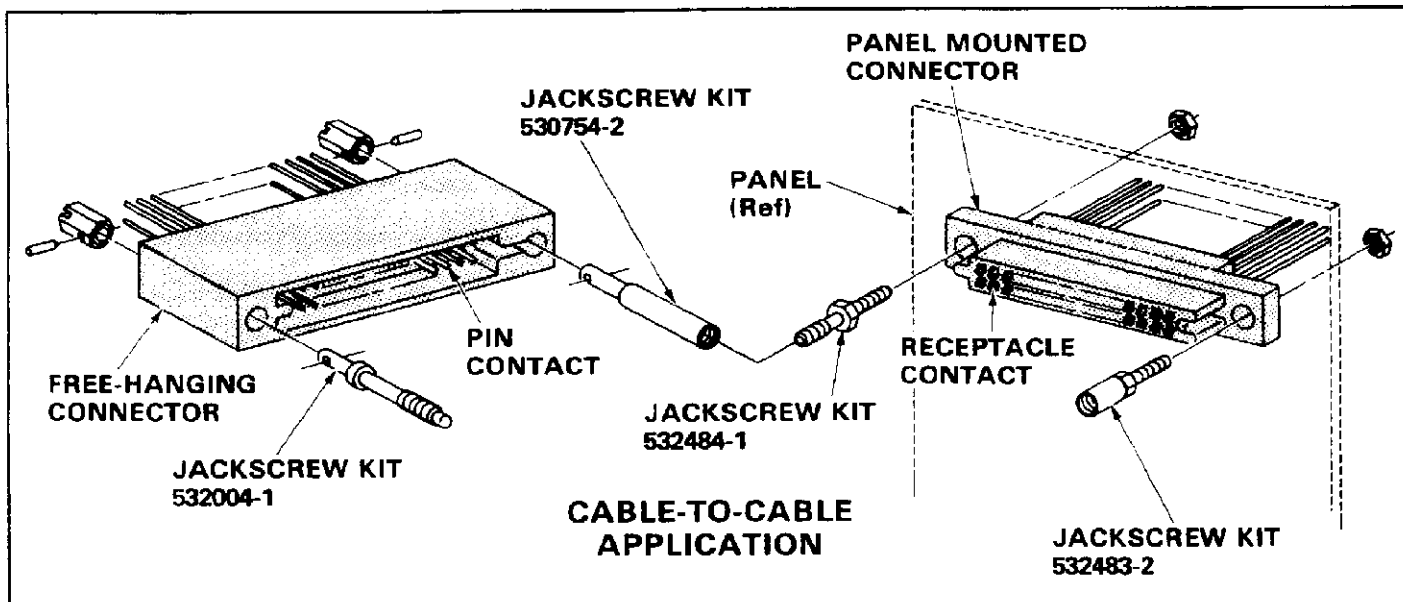

Fig. 3

2. Select two jackscrew kits 532483-1 or 532484-1 (or 1 each) for the panel mounted receptacle contact connector.

3. Assemble each jackscrew in the pin contact connector by inserting the tip into the front of the connector, sliding the body onto the tip shaft, aligning the roll pin holes, and installing the roll pin.

4. Assemble each jackscrew in the receptacle contact connector by inserting the tip into the front of the connector,

through the panel, and securing it with a hex nut.

B. Cable-to-PC Board Connector Application – 1000/1001 Series

1. Free-hanging Cable Connector and Inline PC Board Connector (Figure 4)

1. Select two jackscrew kits 532004-1 or 530754-2 (or 1 each) for the free-hanging pin contact connector.

2. Select two jackscrew kits 532483-1 or 532484-1 (or 1 each) for the mounted receptacle connector.

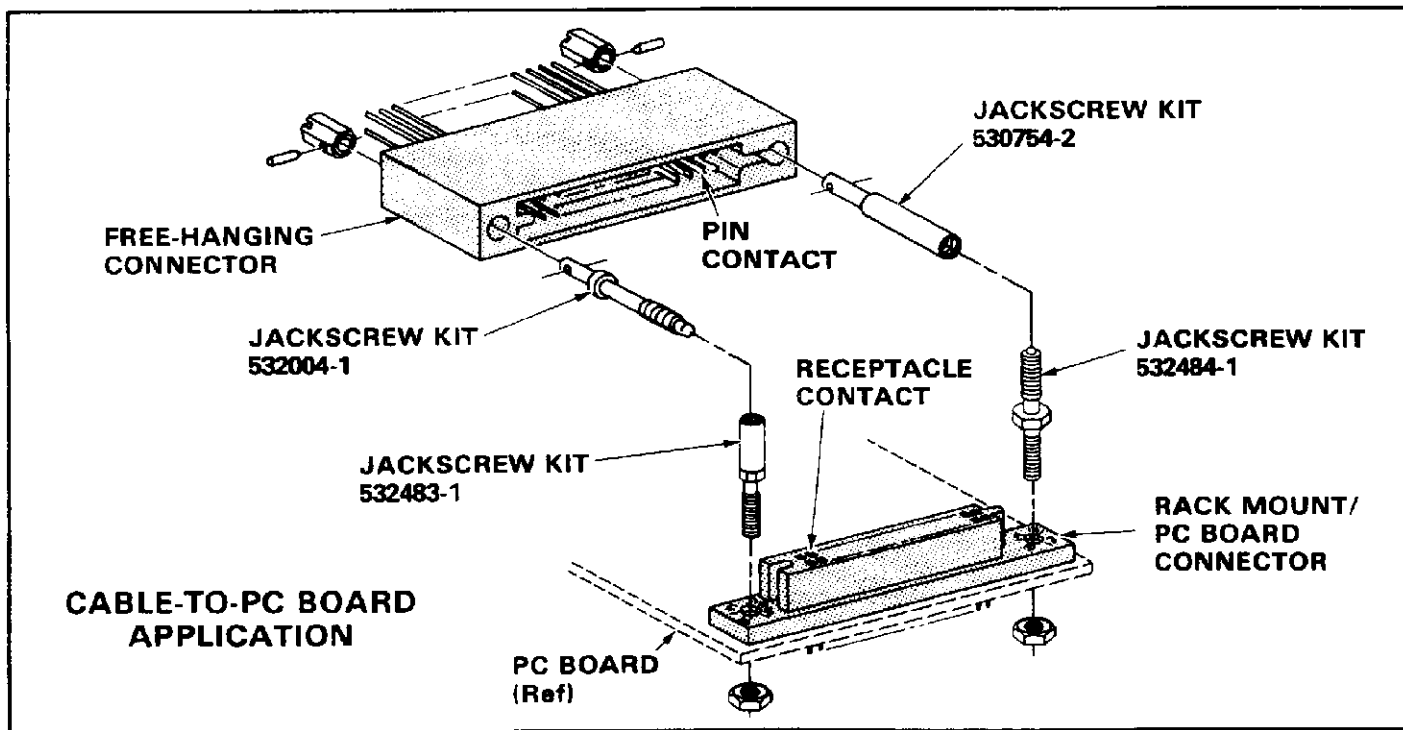

Fig. 4

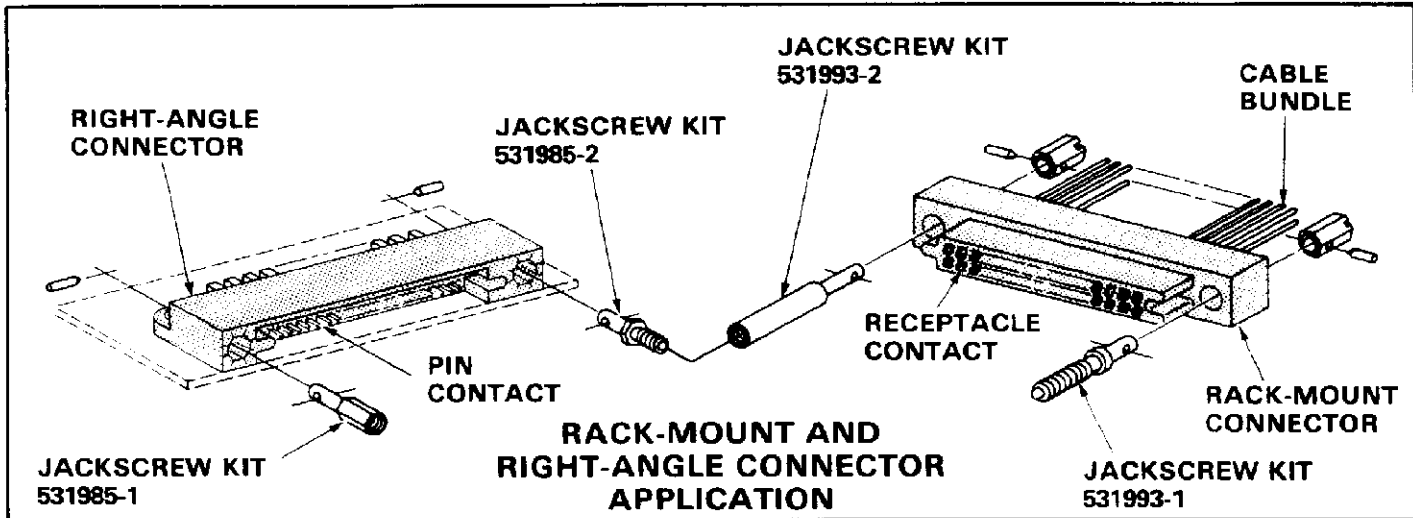

Fig. 5

3. Assemble each jackscrew in the pin contact connector by inserting the tip into the front of the connector, sliding the body onto the tip shaft, aligning the roll pin holes, and installing the roll pin.

4. Assemble each jackscrew in the receptacle contact connector by inserting the tip into the front of the connector, through the panel, and securing it with a hex nut.

2. Rack-Mount and Right-Angle PC Board Connector (Figure 5)

1. Select two jackscrew kits 531993-1 or 531993-2 (or 1 each) for the receptacle contact connector.
2. Select two jackscrew kits 531985-1 or 531985-2 (or 1 each) for the pin contact connector.
3. Assemble each jackscrew in the receptacle contact connector by inserting

the tip into the front of the connector, sliding the body onto the tip shaft, aligning the roll pin holes, and installing the roll pin.

4. Assemble each jackscrew in the pin contact connector by inserting the tip into the front of the connector and securing it with the roll pin.

C. Board-to-Board Connector Application – 501 Series (Figure 6)

1. Select two jackscrew kits 532005-1, 532005-2, or 532005-3 (or 1 each of any two of them) for the connectors.
2. Assemble each kit by inserting the tip into the front of the connector (male or female tip can be installed in either connector).
 - a. If tip requires snap ring, insert ring into snap ring slot.
 - b. If tip requires roll pin, insert body, align roll pin holes, and install roll pin.
 - c. If tip requires a nut, install it securely.

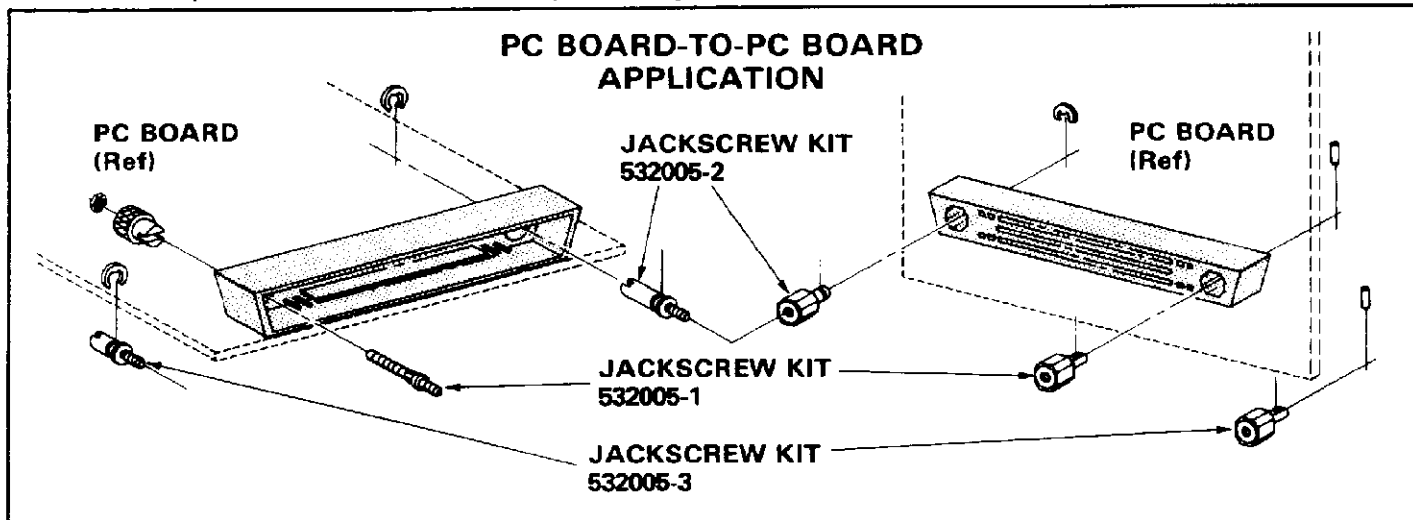

Fig. 6